

D
revised

Middle School Math with

$a^x = b^y$
Pizzazz!

Measurement; Geometry;
Perimeter and Area; Surface
Area and Volume; Square
Roots and Right Triangles

**Mc
Graw
Hill** Wright Group
McGraw-Hill

Steve Marcy, Ph.D.
Janis Marcy, M.A.

The Authors:

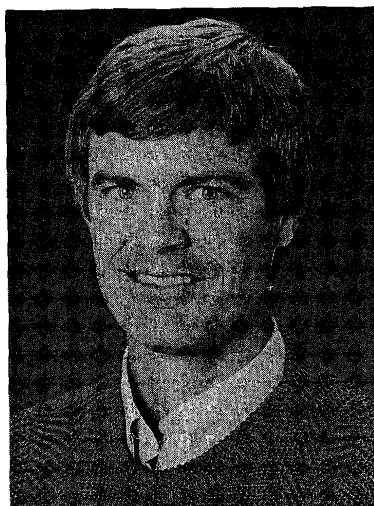

Steve Marcy and Janis Marcy

*Santa Monica-Malibu Unified
School District*

Limited Reproduction Permission: Permission to duplicate these materials is limited to the teacher for whom they are purchased. Reproduction for an entire school or school district is unlawful and strictly prohibited.

For Jennifer, Matt, Andy, and Jazz

Cover by Nimbus Design

Illustrations by Mark Lawler

Technical art by Steve Reiling

Edited by Ann Roper

© 1989, 1996 Wright Group/McGraw-Hill
One Prudential Plaza
Chicago, IL 60601

Printed in U.S.A

ISBN: 0-88488-741-3

6 7 • MAL • 07 06

NOTES FROM THE AUTHORS

MIDDLE SCHOOL MATH WITH PIZZAZZ! is a series of five books designed to provide practice with skills and concepts taught in today's middle school mathematics programs. The series uses many of the same puzzle formats as *PRE-ALGEBRA WITH PIZZAZZ!* and *ALGEBRA WITH PIZZAZZ!* both published by Creative Publications.

We believe that mastery of math skills and concepts requires both good teaching and a great deal of practice. Our goal is to provide puzzle activities that make this practice more meaningful and effective. To this end, we have tried to build into these activities three characteristics:

1. KNOWLEDGE OF RESULTS. Various devices are used in the puzzles to tell students whether or not their answers are correct. Feedback occurs immediately after the student works each exercise. For example, if a particular answer is not in the code or scrambled answer list, the student knows it is incorrect. He or she can then try again or ask for help. Additional feedback and reinforcement occurs when the student finds a puzzle solution that is appropriate. This immediate knowledge of results benefits students and also teachers, who no longer have to spend time confirming correct answers.

2. A MOTIVATING GOAL FOR THE STUDENT*The puzzles are designed so that students will construct a joke or unscramble the answer to a riddle in the process of checking their answers. The humor operates as an incentive, because the students are not rewarded with the punch line until they complete the exercises. While students may decry these jokes as “dumb” and groan loudly, our experience has been that they enjoy the jokes and look forward to solving the puzzles. The humor has a positive effect on class morale. In addition to humor, the variety and novelty of procedures for solving the puzzles help capture student interest. By keeping scrambled answer lists short and procedures simple, we

have tried to minimize the time spent on finding answers or doing other puzzle mechanics.

3. CAREFUL SELECTION OF TOPICS AND EXERCISES. The puzzles within each topic area are carefully sequenced so that each one builds on skills and concepts previously covered. The sequence of exercises within each puzzle is designed to guide students in incremental, step-by-step fashion toward mastery of the skill or concept involved. A primary goal is the development of problem-solving ability. In order to solve problems, students need not only rules and strategies but also a meaningful understanding of basic concepts. Some puzzles in this series are designed specifically to build concepts. Other puzzles, especially those for estimation, also help deepen students' understanding by encouraging them to look at numbers as quantities rather than just as symbols to be manipulated. For puzzles specifically keyed to problem solving, we have tried to write problems that are interesting and uncontrived. We have included extra information in some problems, and have also mixed problem types within sets, so that the problems cannot be solved mechanically.

In addition to these efforts to make the puzzles effective, we have tried to make them easy to use. The topic for each puzzle is given both at the bottom of the puzzle page and in the Table of Contents on pages iv and v. Each puzzle is keyed to a specific topic in recent editions of leading middle school textbooks. Each puzzle requires duplicating only one page, and many of them provide space for student work. Finally, because the puzzles are self-correcting, they can eliminate the task of correcting assignments.

We hope that both you and your students will enjoy using these materials.

Steve and Janis Marcy

Table of Contents

1. MEASUREMENT: METRIC UNITS

a. Length	7
b. Measuring Line Segments with a Ruler	8
c. Renaming Units of Length	9-10
d. Capacity	11
e. Weight.....	12
f. Review: Capacity and Weight	13
g. Time	14

2. MEASUREMENT: CUSTOMARY UNITS

a. Measuring Line Segments with a Ruler	15-17
b. Renaming Units of Length	18-19
c. Capacity	20-21
d. Weight	22
e. Review: Capacity and Weight	23
f. Adding and Subtracting Measurements.....	24

3. GEOMETRY

a. Basic Geometric Figures	25
b. Angles	26
c. Estimating Angle Measures	27
d. Measuring Angles with a Protractor	28
e. Drawing Angles with a Protractor.....	29
f. Complementary and Supplementary Angles.....	30
g. Related Angles Formed by Intersecting Lines	31
h. Parallel and Perpendicular Lines	32
i. Related Angles Formed by Parallel Lines and Transversals	33
j. Triangles	34
k. Review: Related Angles.....	35-36
l. Quadrilaterals.....	37-39
m. Polygons	40
n. Congruent Polygons.....	41
o. Similar Triangles	42
p. Circles	43
q. Lines of Symmetry	44
r. Space Figures	45

4. PERIMETER AND AREA

a. Perimeter	46-47
b. Circumference.....	48-49
c. Area of Rectangles	50-52
d. Using a Calculator: Perimeter and Area.....	53
e. Area of Parallelograms.....	54

f. Area of Triangles.....	55-56
g. Review: Perimeter and Area of Rectangles. Parallelograms. and Triangles	57
h. Area of Trapezoids.....	58
i. Area of Circles.....	59
j. Review: Circumference and Area of Circles	60-61
k. Problem Solving: Mixed Applications.....	62
l. Problem Solving: Choosing a Formula.....	63

5. SURFACE AREA AND VOLUME

a. Surface Area of Rectangular Prisms.....	64
b. Surface Area of Prisms and Pyramids.....	65
c. Surface Area of Cylinders.....	66
d. Volume of Rectangular Prisms.....	67
e. Problem Solving: Mixed Applications.....	68
f. Volume of Prisms.....	69
g. Volume of Cylinders.....	70

6. SQUARE ROOTS AND RIGHT TRIANGLES

a. Squares and Square Roots.....	71-72
b. The Rule of Pythagoras: Finding the Length of the Hypotenuse	73-74
c. The Rule of Pythagoras: Finding the Length of a Side of a Right Triangle	75-76

7. ENRICHMENT

a. Formulas	77
b. Test of Genius.....	78

8. ANSWERS.....79-96

NOTES ABOUT USING THE PUZZLES

The selection of topics for *MIDDLE SCHOOL MATH WITH PIZZAZZ!* reflects recent thinking about what is important in an updated middle school math program. Virtually every puzzle can be matched with a particular lesson in recent editions of popular textbooks. After students have received instruction in a topic and worked some sample exercises, you might assign a puzzle along with a selection of textbook exercises.

Students in the middle grades should begin to classify many mathematics problems and exercises into one of three categories:

- 1. MENTAL MATH.** Problems for which an exact answer can be obtained mentally.
- 2. ESTIMATION.** Problems for which an approximate answer, obtained mentally, is sufficient.
- 3. TOOLS.** Problems requiring an exact answer that cannot be obtained mentally. Students will use paper and pencil and/or calculators.

Some of the puzzles in this series focus specifically on one of these categories. A few puzzles actually present problems in all three categories and ask the student to make the classification.

By the time they reach the middle grades, students should generally be permitted to use calculators for problems that require tools (Category **3**). The most common argument against calculator use is that students will become overly dependent on them. This concern, though, appears to be based primarily on fear that students will rely on the calculator for

problems in Categories 1 and 2, those that should be done mentally.

To solve problems in Category **3**, calculators are wonderful tools for computing. Students may also need paper and pencil to make diagrams, write equations, record results, etc., so they will need both kinds of tools. On the other hand, students should not need calculators for problems in Categories 1 and 2, problems that call for mental math or estimation'. Skills in these areas are essential not only in daily life but also for the intelligent use of the calculator itself. The puzzles in this series reflect these three categories and the distinction between them.

When students do use calculators, you may want to have them write down whatever numbers and operations they punch in and their answers. This makes it easier to identify the cause of any error and assists in class management. Even when students do mental math or estimation puzzles, have them write a complete list of answers and, where appropriate, the process used to get the answers. Encourage students to write each answer before locating it in the answer list. Students should complete *all* the exercises even if they discover the answer to the joke or riddle earlier.

One advantage of using a puzzle as an assignment is that you can easily make a transparency of the page and display the exercises without having to recopy them on the board. You can then point to **parts** of a problem as you discuss it. It is often helpful to cut the transparency apart so that you can display exercises on part of the screen and write solutions on the remaining area.

Other books by Steve and Janis Marcy
published by Creative Publications

Pre-Algebra With Pizzazz! in a Binder
Covers most topics in a pre-algebra curriculum

Algebra With Pizzazz! in a Binder
Covers most topics in a first-year algebra curriculum

How Can You Find a Double-Decker Bus?

For each exercise, circle the letter of the more reasonable measure. Write this letter in the box containing the number of the exercise.

The chart gives an approximate size for each of the most commonly used metric units of length.

Unit	Approximate Size
1 millimeter (mm)	thickness of a dime
1 centimeter (cm)	width of your smallest finger
1 meter (m)	length of a baseball bat
1 kilometer (km)	length of 10 football fields



- | | |
|--|---|
| ① length of an ant
R 5mm M 5cm | ② length of a new pencil
A 19 mm O 19 cm |
| ③ height of a basketball hoop
U 30m H 3m | ④ distance walked in 1 hour
K 5km B 50m |
| ⑤ diameter of a quarter
G 24cm O 24 mm | ⑥ length of a paper clip
E 3cm S 30cm |
| ⑦ length of a tennis court
L 24m D 24 km | ⑧ distance driven on a freeway in 1 hour
U 85 km A 850 m |
| ⑨ thickness of a nickel
E 20mm O 2 mm | ⑩ height of a dining table
K 75 mm S 75 cm |
| ⑪ length of an automobile
T 5 m S 50m | ⑫ length of a marathon race
T 400 m F 40 km |
| ⑬ width of a dollar bill
N 66 cm P 66 mm | ⑭ length of a sheet of typing paper
O 28cm R 28 mm |
| ⑮ height of a door
M 20 cm B 2 m | ⑯ distance from New York to Los Angeles
D 450 km T 4,500 km |

7	2	14	4		12	9	1		11	3	6		15	8	10		16	5	13
---	---	----	---	--	----	---	---	--	----	---	---	--	----	---	----	--	----	---	----

Cryptic Quiz

TOPIC

Measuring Length

Segments With a Ruler

D-8

1. DLE SCHOOL WITH PIZZAZZ! BOOK D © Creative Publications

1. What did the duck say to the store clerk when buying chapstick?

7.3 5.4 13.6 228 232 8 5.4 228 1.2 71 228 4.6 107 17.4 61 15.7 54 224 42 71 5.0 5.0

2. Why didn't Noah catch many fish during the voyage of the ark?

136 0.8 15.0 136 65 7.1 118 107 17.4 5.0 54 6.9 228 113 107 47 113 107 5.9 15.7 13.6

For each exercise, measure the line segment to the nearest millimeter. Express the measurement in millimeters or centimeters, as indicated, and find your answer in the code. Each time the answer appears, write the letter of the exercise above it.

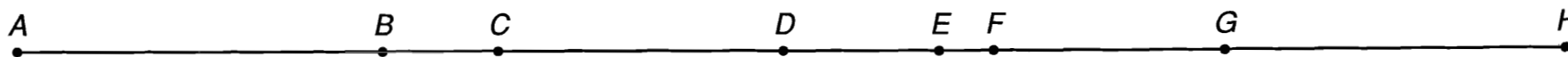

(U) length of \overline{AB} = _____ cm

(R) length of \overline{BD} = _____ cm

(J) length of \overline{CF} = _____ cm

(Y) length of \overline{AB} = _____ mm

(N) length of \overline{BH} = _____ cm

(M) length of \overline{CH} = _____ cm

(D) length of \overline{AC} = _____ cm

(E) length of \overline{EF} = _____ cm

(L) length of \overline{GH} = _____ cm

(I) length of \overline{AC} = _____ mm

(P) length of \overline{EF} = _____ mm

(B) length of \overline{EG} = _____ mm

(S) length of \overline{AE} = _____ cm

(A) length of \overline{DG} = _____ mm

(W) length of \overline{AD} = _____ mm

(H) length of \overline{AE} = _____ mm

(O) length of \overline{CG} = _____ mm

(T) length of \overline{AH} = _____ mm

Why Are Scales Like Roadmaps?

Do each exercise and find your answer in the set of answers to the right, Write the letter of the answer in the box containing the number of the exercise. If the answer has a ●, shade in the box instead of writing a letter in it.

I. Answer each question.

① How many mm are in 1 cm? _____

② How many cm are in 1 m? _____

③ How many m are in 1 km? _____

Answers 1 – 3:

- T 10 H 100
 E 1,000 R 10,000

II. Complete each statement. You are changing each measure to a smaller unit.

④ 2.75 m = _____ cm

⑤ 8.3 m = _____ cm

⑥ 41.9 cm = _____ mm

⑦ 6.25 cm = _____ mm

⑧ 1.875 km = _____ m

⑨ 27.5 km = _____ m

⑩ 0.4 m = _____ cm

⑪ 3.666 m = _____ dm

Answers 4 – 11:

- U 3,666 S 27,500
 R 6,250 E 830
 419 K 2.75
 T 40 G 1,875
 W 275 D 41,900
 L 18.75 H 62.5
 36.66 C 4,000

III. Complete each statement. You are changing each measure to a larger unit.

⑫ 12.5 mm = _____ cm

⑬ 94 mm = _____ cm

⑭ 375 m = _____ km

⑮ 88 m = _____ km

⑯ 643 cm = _____ m

⑰ 2.5 cm = _____ m

⑱ 250 mm = _____ dm

⑲ 5,000 m = _____ km

Answers 12 – 19:

- H 0.375 R 0.094
 Q 0.25 W 5
 P 500 O 1.25
 6.43 E 0.088
 H 2.5 37.5
 Y 9.4 U 0.0643
 A 8.8 I 0.025

10	2	5	13	16	9	18	12	4	6	1	7	15	11	19	3	17	8	14
----	---	---	----	----	---	----	----	---	---	---	---	----	----	----	---	----	---	----

Why Did the Hen Jump Up and Down When She Looked Into the Nest?



Complete each statement, then find your answer in the set of answers to the right.
Write the letter of the exercise in the box containing the number of the answer.

<p>G 3.8 m = _____ dm</p> <p>T 3.8 m = _____ cm</p> <p>M 3.8 m = _____ mm</p> <p>A 490 cm = _____ dm</p> <p>N 490 cm = _____ m</p> <p>T 490 cm = _____ hm</p> <p>1 27.5 m = _____ cm</p> <p>M 27.5 m = _____ dam</p> <p>N 27.5 m = _____ km</p> <p>H 9.3 dm = _____ mm</p> <p>I 9.3 dm = _____ cm</p> <p>G 9.3 dm = _____ m</p>	<p>Answers</p> <p>2 380</p> <p>24 3,800</p> <p>17 38</p> <p>5 38,000</p> <p>26 0.49</p> <p>29 0.049</p> <p>21 4.9</p> <p>5 49</p> <p>26 2.75</p> <p>20 2,750</p> <p>25 275</p> <p>9 0.0275</p> <p>1 93</p> <p>8 9,300</p> <p>22 0.93</p> <p>18 930</p>
<p>S 0.08 km = _____ hm</p> <p>O 0.08 km = _____ m</p> <p>G 0.08 km = _____ cm</p> <p>A 7,400 cm = _____ mm</p> <p>I 7,400 cm = _____ m</p> <p>E 7,400 cm = _____ km</p> <p>W 60 dam = _____ km</p> <p>G 60 dam = _____ m</p> <p>N 60 dam = _____ cm</p> <p>E 1,000 mm = _____ cm</p> <p>S 1,000 mm = _____ m</p> <p>T 1,000 mm = _____ km</p>	<p>Answers</p> <p>25 80</p> <p>13 8,000</p> <p>3 800</p> <p>6 0.8</p> <p>23 7.4</p> <p>27 0.074</p> <p>16 74</p> <p>8 74,000</p> <p>4 0.6</p> <p>28 60,000</p> <p>12 600</p> <p>7 6,000</p> <p>15 1</p> <p>23 10</p> <p>11 100</p> <p>19 0.001</p>

1	2	3	4	5	6	7	8	9	10	11	12	13	14	15	16	17	18	19	20	21	22	23	24	25	26	27	28	29
---	---	---	---	---	---	---	---	---	----	----	----	----	----	----	----	----	----	----	----	----	----	----	----	----	----	----	----	----

What Did the Finger Say to the Thumb?

Choose the correct answer for each exercise. Write the letter of the answer in the box containing the number of the exercise. The table below may help you.

Unit	Approximate Size
1 milliliter (mL)	capacity of an eyedropper
1 liter (L)	capacity of a juice carton
1 kiloliter (kL)	capacity of 4 bathtubs

I. Choose the more reasonable estimate of capacity.

- | | | |
|--|---|--|
| <p>① a pot for cooking
K 2 kL E 2 L</p> | <p>② a tablespoon
C 15 L I 15 mL</p> | <p>③ an automobile gas tank
N 50 L P 5 kL</p> |
| <p>④ a swimming pool
A 80 L O 80 kL</p> | <p>⑤ a drinking glass
O 25 mL M 250 mL</p> | <p>⑥ a water cooler jug
H 20 L R 2 L</p> |



II. Complete each statement.

Answers 7 – 14:

- | | | |
|-----------------------|----------------|-----------------|
| ⑦ 8.5 L = _____ mL | B 25 | Y 90 |
| ⑧ 0.4 L = _____ mL | U 1,750 | W 40,000 |
| ⑨ 90,000 mL = _____ L | O 8,500 | F 32 |
| ⑩ 250 mL = _____ L | D 4,000 | I 0.75 |
| ⑪ 1.75 kL = _____ L | S 900 | R 175 |
| ⑫ 40 kL = _____ L | G 0.25 | I 400 |
| ⑬ 750 L = _____ kL | T 3.2 | U 7.5 |
| ⑭ 3,200 L = _____ kL | | |



III. Solve.

Answers 15 – 16:

- | | | |
|---|-------------|--------------|
| ⑮ Ms. Sparkle bought 12 cans of diet soda. Each can contained 350 mL. How many liters of soda did she buy? | R 48 | V 4.2 |
| ⑯ Chef Pierre made 6.4 L of creamed carrot soup. If it is served in 200-mL cups, how many cups can be filled? | L 32 | N 5.4 |

8	5		13	3		10	16	7	15	1		12	2	14	6		9	4	11
---	---	--	----	---	--	----	----	---	----	---	--	----	---	----	---	--	---	---	----

What Do Salmon and Cod Use When They Go to War?

Choose the correct answer for each exercise. Find the letter of the answer in the string of letters near the bottom of the page and CROSS IT OUT each time it appears. When you finish, write the remaining letters in the rectangle at the bottom of the page. The table below may help you.

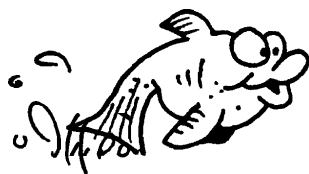

Unit	Approximate Size
1 milligram (mg)	mass (weight) of a grain of sand
1 gram (g)	mass (weight) of a paperclip
1 kilogram (kg)	mass (weight) of a math textbook



I. Choose the more reasonable estimate of weight.

- | | | |
|--------------------------------|--|---------------------------------------|
| ① a nickel
Ⓜ 5 g Ⓝ 5 kg | ② a postage stamp
Ⓐ 60 g Ⓨ 60 mg | ③ a bowling ball
Ⓑ 7 kg Ⓚ 70 kg |
| ④ a lemon
Ⓧ 12 g Ⓦ 120 g | ⑤ a 12-year-old child
Ⓩ 40 kg Ⓛ 4 kg | ⑥ a postcard
Ⓠ 75 g ⓐ 750 mg |

II. Complete each statement.

- ⑦ 6.5 g = _____ mg
- ⑧ 0.8 g = _____ mg
- ⑨ 4,900 mg = _____ g
- ⑩ 133 mg = _____ g
- ⑪ 7.25 kg = _____ g
- ⑫ 60 kg = _____ g
- ⑬ 250 g = _____ kg
- ⑭ 80,000 g = _____ kg

Answers 7 – 14:

- ⓓ 490 Ⓛ 0.133
- Ⓣ 800 Ⓒ 60,000
- Ⓣ 725 Ⓥ 6,500
- Ⓕ 2.5 Ⓚ 13.3
- Ⓟ 4.9 Ⓤ 7,250
- Ⓢ 0.6 Ⓓ 80
- Ⓔ 0.25 Ⓛ 65

III. Solve.

- ⑮ An average orange weighs 270 g. How many kilograms does a bag of 8 oranges weigh?
- ⑯ A vitamin tablet weighs 1.2g. It contains 150 mg of Vitamin C and 250 mg of B Complex vitamins. How many milligrams of other ingredients are in the tablet?

Answers 15 – 16:

- Ⓣ 1.96 Ⓞ 800
- Ⓕ 920 Ⓡ 2.16

B R Y L F E G O I P M C S O D H W T R B G A L O N Z U K V E S J

Answer to puzzle: _____

Why Did the Ice Skater Tell Jokes While Performing?



Do each exercise and find your answer in the set of answers to the right. Write the letter of the answer in each box containing the number of the exercise. If the answer has a ●, shade in each box containing that exercise number.

I. Complete each statement.

- | | | | | | | | | | |
|---|-------------------------|----|--------------------|----|-------|----|-------|----|--------|
| 1 | 8.3 kg = _____ g | 2 | 830 mg = _____ g | 3 | 309 | 4 | 400 | 5 | 660 |
| 3 | 27.5 g = _____ mg | 4 | 2,750 g = _____ kg | 6 | 2.75 | 7 | 8,300 | 8 | 40,000 |
| 5 | 4,000,000 mg = _____ kg | 6 | 0.66 kL = _____ L | 9 | 3,090 | 10 | 6.6 | 11 | 27,500 |
| 7 | 66,000 mL = _____ L | 8 | 3.09 L = _____ mL | 12 | 66 | 13 | 4 | 14 | 0.0309 |
| 9 | 30.9 L = _____ kL | 10 | 0.04 kL = _____ mL | 15 | 0.83 | 16 | 275 | 17 | 83 |

Answers 1 – 10:

II. Solve.

- 11 A jar of sweet pickles contains 650 g of pickles. There are 12 jars in a case. How many kilograms of pickles are in a case? _____ kg
- 13 A costume designer bought $1\frac{1}{4}$ kg of colorful sequins. She used 250 g of sequins to make a crown and 200 g to make a cape. How many grams of sequins were left? _____ g
- 15 A gasoline can was filled with 17.5 L of gasoline. A lawnmower fuel tank that holds 1.4 L has been filled 8 times from the gasoline can. How much gasoline is left in the can? _____ L
- 12 A large can of frozen orange juice contains 354 ml. To make orange juice, you add 3 full cans of water. How many liters of orange juice does this make? _____ L
- 14 Mrs. Sipp has 4.6 L of lemonade to serve her son's 20 birthday guests. About how many milliliters should she pour into each glass? _____ mL
- 16 ABC Corporation is mailing a report to stockholders. The report includes a cover and 100 sheets of paper. If the cover weighs 0.2 kg and each sheet of paper weighs 5 g, how much does the report weigh? _____ g

Answers 11 – 16:

- | | | | |
|----|-----|----|-------|
| 11 | 5.8 | 12 | 8.4 |
| 13 | 840 | 14 | 1.416 |
| 15 | 230 | 15 | 700 |
| | 620 | 16 | 280 |
| | 7.8 | | 750 |
| | 6.3 | | 1.606 |

16	11	2	13	5	8	16	1	13	16	10	3	15	15	3	14	7	13	8	12	4	6	14	15
----	----	---	----	---	---	----	---	----	----	----	---	----	----	---	----	---	----	---	----	---	---	----	----

E	14 min 30 s
S	1; 55
R	15 min 26 s
K	3 d 15 h
Y	420
N	3 min 28 s
O	6 h 28 min
B	3
W	6 h 15 min
H	4 min 40 s
C	3,920
O	72
D	240
E	2 d 17 h
B	3 min 42 s
U	1; 20
X	12 h 28 min
A	9 h 51 min
T	310
N	12 h 42 min
E	14 min 56 s
P	9
R	4,320
O	11 h
T	10 h 58 min
S	150
H	6 h 40 min
A	2; 15

What Should You Study to Learn How to be a Cowboy?

Cross out the letter next to each correct answer. When you finish, the answer to the title question will remain.

I. Complete each statement.

- ① 4 h = _____ min
- ② 7 min = _____ sec
- ③ 2 h 30 min = _____ min
- ④ 5 min 10 sec = _____ sec
- ⑤ 180 min = _____ h
- ⑥ 540 sec = _____ min
- ⑦ 80 min = _____ h _____ min
- ⑧ 135 sec = _____ min _____ sec
- ⑨ 3 d = _____ h
- ⑩ 3 d = _____ min

II. Add or subtract. Simplify if possible.

- ⑪
$$\begin{array}{r} 2 \text{ h } 30 \text{ min} \\ + 3 \text{ h } 45 \text{ min} \\ \hline \end{array}$$
- ⑫
$$\begin{array}{r} 5 \text{ min } 40 \text{ s} \\ + 8 \text{ min } 50 \text{ s} \\ \hline \end{array}$$
- ⑬
$$\begin{array}{r} 7 \text{ h } 8 \text{ min} \\ + 2 \text{ h } 43 \text{ min} \\ \hline \end{array}$$
- ⑭
$$\begin{array}{r} 8 \text{ min } 10 \text{ s} \\ - 3 \text{ min } 30 \text{ s} \\ \hline \end{array}$$
- ⑮
$$\begin{array}{r} 12 \text{ h } 25 \text{ min} \\ - 5 \text{ h } 45 \text{ min} \\ \hline \end{array}$$
- ⑯
$$\begin{array}{r} 32 \text{ min } 50 \text{ s} \\ - 17 \text{ min } 24 \text{ s} \\ \hline \end{array}$$
- ⑰
$$\begin{array}{r} 6 \text{ h } 47 \text{ min} \\ + 4 \text{ h } 13 \text{ min} \\ \hline \end{array}$$
- ⑱
$$\begin{array}{r} 9 \text{ min} \\ - 5 \text{ min } 32 \text{ s} \\ \hline \end{array}$$
- ⑲
$$\begin{array}{r} \text{ d } 14 \text{ h} \\ - 5 \text{ d } 11 \text{ h} \\ \hline \end{array}$$

III. Solve.

- ⑳ It takes 15 h 20 min to travel from Los Angeles to Salt Lake City by train. It takes only 2 h 38 min to fly between the two cities. How much longer does the train take?

What Has Four Legs and Flies?

This title question has TWO different answers. Part I gives you one answer and Part II gives you the other. Follow the directions for each part.



- I. Identify each measurement that is marked with a letter. Write each letter in the box that contains the corresponding measurement.

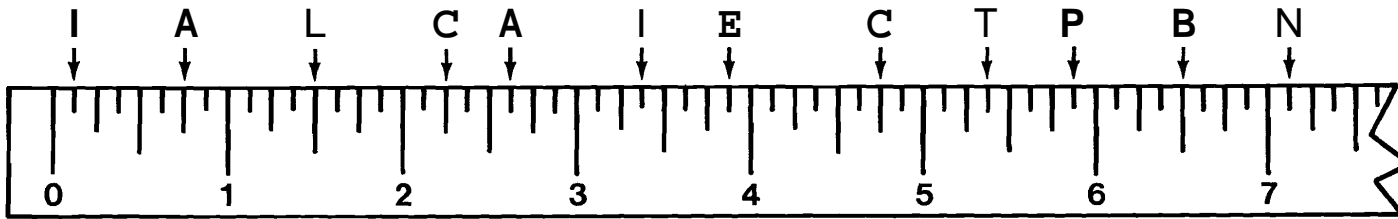

$2\frac{5}{8}$ in.	$5\frac{1}{2}$ in.	$5\frac{7}{8}$ in.	$\frac{1}{8}$ in.	$4\frac{3}{4}$ in.	$7\frac{1}{8}$ in.	$3\frac{3}{8}$ in.	$2\frac{1}{4}$ in.	$6\frac{3}{4}$ in.	$5\frac{3}{8}$ in.	$\frac{3}{4}$ in.	$6\frac{1}{2}$ in.	$1\frac{1}{2}$ in.	$3\frac{7}{8}$ in.
--------------------	--------------------	--------------------	-------------------	--------------------	--------------------	--------------------	--------------------	--------------------	--------------------	-------------------	--------------------	--------------------	--------------------

- II. For each exercise, measure the line segment to the nearest $\frac{1}{8}$ inch. Write the letter of the exercise in the box containing the measurement.

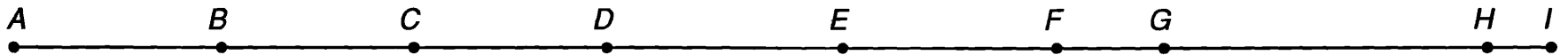

- | | | | | |
|-------------------------------|-------------------------------|-------------------------------|-------------------------------|-------------------------------|
| (O) \overline{AB} _____ in. | (A) \overline{AC} _____ in. | (S) \overline{AD} _____ in. | (W) \overline{AE} _____ in. | (I) \overline{AF} _____ in. |
| (A) \overline{AG} _____ in. | (S) \overline{AH} _____ in. | (T) \overline{AI} _____ in. | (O) \overline{BG} _____ in. | (F) \overline{BH} _____ in. |
| (T) \overline{DG} _____ in. | (P) \overline{DH} _____ in. | (R) \overline{FG} _____ in. | (N) \overline{FI} _____ in. | (P) \overline{HI} _____ in. |

$3\frac{1}{4}$	$4\frac{7}{8}$	$5\frac{1}{2}$	$3\frac{5}{8}$	$\frac{3}{8}$	$2\frac{3}{8}$	$6\frac{1}{8}$	$\frac{5}{8}$	$8\frac{5}{8}$	$5\frac{1}{4}$	$1\frac{1}{4}$	$7\frac{3}{8}$	$\frac{1}{2}$	$5\frac{1}{8}$	$6\frac{3}{4}$	$2\frac{7}{8}$	9	$3\frac{1}{2}$
----------------	----------------	----------------	----------------	---------------	----------------	----------------	---------------	----------------	----------------	----------------	----------------	---------------	----------------	----------------	----------------	---	----------------

Why Do Elephants Lift Weights?

Measure each line segment below to the nearest one-eighth inch. Find your answer in the answer column. Write the letter of the exercise in the box containing the number of the answer.

(E) _____
 (T) _____
 (R) _____
 (H) _____
 (E) _____
 (I) _____
 (T) _____
 (A) _____
 (E) _____
 (I) _____
 (R) _____
 (O) _____
 (T) _____
 (X) _____
 (E) _____
 (Z) _____
 (G) _____
 (T) _____
 (S) _____

- ① $3\frac{7}{8}$ in.
- ② $2\frac{7}{8}$ in.
- ③ $\frac{7}{8}$ in.
- ④ $5\frac{1}{4}$ in.
- ⑤ $4\frac{1}{4}$ in.
- ⑥ $4\frac{3}{8}$ in.
- ⑦ $3\frac{1}{8}$ in.
- ⑧ $5\frac{1}{8}$ in.
- ⑨ $3\frac{5}{8}$ in.
- ⑩ $\frac{3}{4}$ in.
- ⑪ $2\frac{1}{2}$ in.
- ⑫ $1\frac{5}{8}$ in.
- ⑬ $1\frac{3}{8}$ in.
- ⑭ $1\frac{3}{4}$ in.
- ⑮ $4\frac{1}{2}$ in.
- ⑯ $2\frac{5}{8}$ in.
- ⑰ 2 in.
- ⑱ $4\frac{3}{4}$ in.
- ⑲ $3\frac{3}{8}$ in.

1	2	3	4	5	6	7	8	9	10	11	12	13	14	15	16	17	18	19
---	---	---	---	---	---	---	---	---	----	----	----	----	----	----	----	----	----	----

Measure with Pleasure

Follow the directions below. When you complete each step, put an \times in front of it. Measure carefully and you will get the picture!

- ___ 1. Copy rectangle ABCD on another sheet of paper. The rectangle is 7 in. wide and $9\frac{1}{2}$ in. high.
- ___ 2. Place your ruler on \overline{AB} . Measure $3\frac{1}{8}$ in. across from Point A. Make a dot to mark this point. Label it Point E.
- ___ 3. Place your ruler on \overline{BC} . Measure down $1\frac{1}{4}$ in. from Point B. Make a dot to mark this point. Label it Point F.
- ___ 4. On \overline{BC} , measure down $5\frac{7}{8}$ in. from B. Label this Point G.
- ___ 5. Point H is on \overline{BC} , $7\frac{3}{8}$ in. from B.
- ___ 6. Point I is on \overline{BC} , $8\frac{3}{8}$ in. from B.
- ___ 7. Point J is on \overline{AD} , 7 in. from A. Connect points H and J.
- ___ 8. Point K is on \overline{AD} , $8\frac{1}{2}$ in. from A. Connect points I and K.
- ___ 9. Point L is on \overline{JH} , $3\frac{1}{8}$ in. from J. Draw \overline{EL} .
- ___ 10. Point M is on \overline{EL} , $\frac{7}{8}$ in. from E. Draw \overline{GM} .
- ___ 11. Point N is on \overline{AD} , $5\frac{3}{4}$ in. from A. Draw \overline{MN} .
- ___ 12. Line up your ruler on Points E and F. Mark a point 1 in. from E and label it Point O. Connect points E and O.
- ___ 13. Point P is on \overline{EL} , $\frac{5}{8}$ in. from E. Draw \overline{OP} .
- ___ 14. Point Q is on \overline{EL} , $6\frac{1}{4}$ in. from E. Draw \overline{OQ} .
- ___ 15. Point R is on \overline{EL} , $6\frac{5}{8}$ in. from E. Draw \overline{NR} .
- ___ 16. Point S is on \overline{NR} , $2\frac{3}{4}$ in. from N. Draw \overline{MS} .
- ___ 17. Point T is on \overline{KI} , $1\frac{1}{8}$ in. from K. Draw \overline{JT} .
- ___ 18. Point U is on \overline{KI} , 6 in. from K. Draw \overline{HU} .

What Is the Title?

TO FIND THE TITLE OF THIS PICTURE:

Do each exercise below. Find your answer in the code and write the letter of the exercise above it. (Each answer appears only once.)

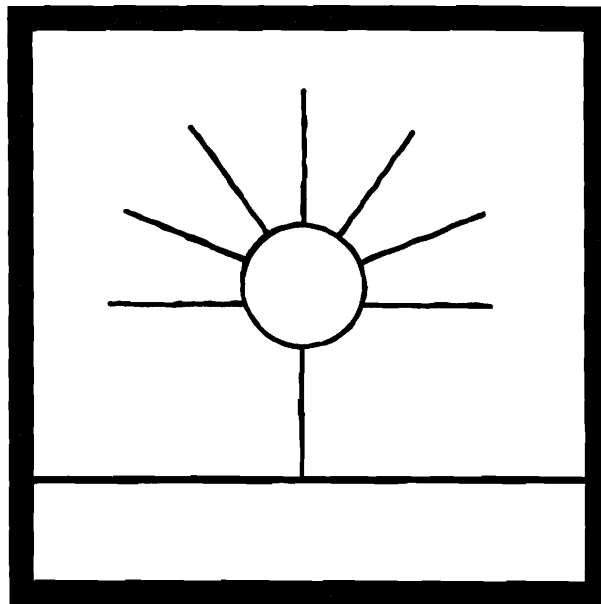

CODED TITLE:

72 1;20 5;9 11;2 3 15 98 4 3;1 18 12 61

8;16 24 7 5 29 126 36 10;6 60 1;7 8 100

I. Answer each question.

(N) How many inches are in 1 foot? _____

(E) How many feet are in 1 yard? _____

(D) How many inches are in 1 yard? _____

II. Complete each statement.

You are changing each measure to a smaller unit.

(A) 2 ft = _____ in.

(T) 5 ft = _____ in.

(I) 1 ft 6 in. = _____ in.

(D) 8 ft 4 in. = _____ in.

(R) 5 yd = _____ ft

(A) 9 yd 2 ft = _____ ft

(G) 20 yd 1 ft = _____ ft

(S) 2 yd = _____ in.

(N) 3 yd 18 in. = _____ in.

III. Complete each statement.

You are changing each measure to a larger unit.

(D) 48 in. = _____ ft

(A) 19 in. = _____ ft _____ in.

(I) 69 in. = _____ ft _____ in.

(N) 24 ft = _____ yd

(O) 10 ft = _____ yd _____ ft

(D) 35 ft = _____ yd _____ ft

(H) 180 in. = _____ yd

(P) 56 in. = _____ yd _____ in.

(S) 366 in. = _____ yd _____ in.

What Did Airhead Klutz Look For When He First Took Up Waterskiing?

Find each answer in the set of boxes under the exercise. Write the letter of the exercise in the space above the answer.

I. Complete each statement.

- (I) 7 ft = _____ in. (C) 4 ft 10 in. = _____ in. (A) 10 ft 3 in. = _____ in.
 (T) 8 yd = _____ ft (E) 5 yd 2 ft = _____ ft (I) 4 yd = _____ in.
 (W) 60 in. = _____ ft (A) 40 in. = _____ ft _____ in. (E) 72 in. = _____ yd
 (H) $2\frac{1}{2}$ ft = _____ in. (L) $7\frac{2}{3}$ yd = _____ ft (N) 100 ft = _____ yd _____ ft
 (K) A baseball diamond is a square with 90 feet between bases. About how many **yards** does a player run after hitting a home run? _____ yd

3;4	28	33;1	144	58	2	140	23	123	120	17	9;1	5	84	24	30	

II. Add or subtract. Simplify if possible.

- (G) $\begin{array}{r} 3 \text{ ft } 7 \text{ in.} \\ + 2 \text{ ft } 8 \text{ in.} \\ \hline \end{array}$ (I) $\begin{array}{r} 5 \text{ ft } 9 \text{ in.} \\ + 8 \text{ ft } 10 \text{ in.} \\ \hline \end{array}$ (L) $\begin{array}{r} 13 \text{ ft } 2 \text{ in.} \\ + 6 \text{ ft } 8 \text{ in.} \\ \hline \end{array}$ (N) $\begin{array}{r} 3 \text{ yd } 2 \text{ ft} \\ + 4 \text{ yd } 2 \text{ ft} \\ \hline \end{array}$
 (A) $\begin{array}{r} 9 \text{ ft } 11 \text{ in.} \\ - 4 \text{ ft } 6 \text{ in.} \\ \hline \end{array}$ (I) $\begin{array}{r} 7 \text{ ft } 4 \text{ in.} \\ - 2 \text{ ft } 7 \text{ in.} \\ \hline \end{array}$ (T) $\begin{array}{r} 10 \text{ ft } 8 \text{ in.} \\ - 3 \text{ ft } 11 \text{ in.} \\ \hline \end{array}$ (I) $\begin{array}{r} 14 \text{ yd } 1 \text{ ft} \\ - 8 \text{ yd } 2 \text{ ft} \\ \hline \end{array}$
 (L) $\begin{array}{r} 12 \text{ ft } 6 \text{ in.} \\ + 7 \text{ ft } 6 \text{ in.} \\ \hline \end{array}$ (B) $\begin{array}{r} 20 \text{ ft} \\ - 5 \text{ ft } 8 \text{ in.} \\ \hline \end{array}$ (I) $\begin{array}{r} 9 \text{ yd } 2 \text{ ft} \\ + 6 \text{ yd } 1 \text{ ft} \\ \hline \end{array}$ (H) $\begin{array}{r} 36 \text{ yd} \\ - 28 \text{ yd } 1 \text{ ft} \\ \hline \end{array}$

5 ft 5 in.	5 ft 11 in.	14 ft 4 in.	5 yd 2 ft	6 ft 3 in.	14 ft 3 in.	7 yd 2 ft	4 ft 9 in.	19 ft 10 in.	20 ft	7 yd 1 ft	16 yd	8 yd 1 ft	19 ft 6 in.	14 ft 7 in.	6 ft 9 in.	

Why Did the Young Actress Stuff Her Autograph Into Bottles of that Low-Calorie Cola?



Find each answer in the appropriate set of boxes at the bottom of the page. Write the letter of the exercise in the box containing the answer.

I. Complete each statement.
You are changing each measure to a smaller unit.

(E) 5 gal = _____ qt

(T) 9 gal = _____ qt

(O) 2 qt = _____ pt

(A) 15 qt = _____ pt

(E) 1 pt = _____ c

(D) 7 pt = _____ c

(S) 3 c = _____ fl oz

(T) 10 c = _____ fl oz

(E) 1 gal 2 qt = _____ qt

(S) 6 gal 3 qt = _____ qt

(W) 4 pt 1 c = _____ c

(H) 1 gal = _____ pt

(E) 1 pt = _____ fl oz

(N) 1 qt = _____ fl oz

II. Complete each statement.
You are changing each measure to a larger unit.

(N) 12 qt = _____ gal

(E) 40 qt = _____ gal

(S) 8 pt = _____ qt

(A) 24 pt = _____ qt

(I) 10 c = _____ pt

(R) 18 c = _____ pt

(E) 16 fl oz = _____ c

(M) 64 fl oz = _____ c

(I) 7 qt = _____ gal _____ qt

(H) 30 qt = _____ gal _____ qt

(E) 9 pt = _____ qt _____ pt

(L) 25 c = _____ pt _____ c

(N) 12 fl oz = _____ c _____ fl oz

(T) 50 fl oz = _____ c _____ fl oz

Answers for Column I

24	8	20	15	9	30	32	36	6	14	12	80	4	48	27	16	2
----	---	----	----	---	----	----	----	---	----	----	----	---	----	----	----	---

Answers for Column II

7;2	10	9	14	1;4	12	8	4;1	7	1;3	3	8;1	12;1	5	6;2	2	4
-----	----	---	----	-----	----	---	-----	---	-----	---	-----	------	---	-----	---	---

Did You Hear About...

A	B	C	D	E	F	G	H	I	J	K	L
M	N	O	P	Q	R	S	T	U	V	W	X
											?

Answers A – L:

48 SAID
19 THE
75 TO
10 WHO
5 HE
224 BECAUSE
12 THE
14 RIGHT
2 THAT
32 GOING
16 DRIVER
28 WAY
180 ON
4 WAS

Do each exercise and find your answer in the appropriate answer column. Notice the word next to the answer. Write this word in the box containing the letter of the exercise.

I. Complete each statement.

- | | | |
|-------------------------|----------------------------------|-------------------------------------|
| (A) 3 gal = _____ qt | (B) 8 pt = _____ c | (C) 5 qt = _____ pt |
| (D) 6 c = _____ fl oz | (E) $\frac{1}{2}$ gal = _____ qt | (F) $2\frac{1}{2}$ pt = _____ c |
| (G) 1 qt = _____ c | (H) 1 qt = _____ fl oz | (I) 4 gal 3 qt = _____ qt |
| (J) 7 qt = _____ pt | (K) 7 qt = _____ c | (L) 7 qt = _____ fl oz |
| (M) 20 qt = _____ gal | (N) 12 pt = _____ qt | (O) 16 fl oz = _____ c |
| (P) 36 c = _____ pt | (Q) 8 pt = _____ gal | (R) 9 qt = _____ gal _____ qt |
| (S) 48 fl oz = _____ pt | (T) 60 c = _____ qt | (U) 100 fl oz = _____ c _____ fl oz |

II. Solve.

- (V) Mr. Fizz bought 6 cans of root beer. Each can contained 12 fl oz. How many cups of root beer did he buy? _____ c
- (W) A certain paint is sold in both 1-gal cans and 1-qt cans. The gallon can costs \$13 and the quart can costs \$5. How much do you save per gallon by buying the larger cans? \$_____
- (X) Mrs. Ramirez bought 2 qt of orange juice. If the juice is served in 6-oz glasses, how many glasses can be completely filled? _____

Answers M – X:

9 ONLY
2;1 THEN
6 LEFT
12;4 THE
13 GOING
1 RIGHT
15 IS
7 WAY
5 IF
2 IS
10 LEFT
9;6 A
3 RIGHT
18 NOT

What Did They Call the Guy Who Made 367 Mistakes While Typing One Page?

Cross out the box containing each correct answer. When you finish, write the letters from the remaining boxes in the spaces at the bottom of the page.

I. Complete each statement.

- | | |
|-------------------------------|-------------------------------|
| ① 5 lb = _____ oz | ② 2 lb 12 oz = _____ oz |
| ③ 3 lb 8 oz = _____ oz | ④ 10 lb 3 oz = _____ oz |
| ⑤ $\frac{1}{2}$ lb = _____ oz | ⑥ 3 T = _____ lb |
| ⑦ 1 T 700 lb = _____ lb | ⑧ $4\frac{1}{2}$ T = _____ lb |
| ⑨ 48 oz = _____ lb | ⑩ 42 oz = _____ lb _____ oz |
| ⑪ 100 oz = _____ lb _____ oz | ⑫ 10,000 lb = _____ T |
| ⑬ 5,600 lb = _____ T _____ lb | ⑭ 1 T = _____ oz |

II. Solve.

- | | |
|--|--|
| ⑮ How many ounces of meat are used to make a $\frac{1}{4}$ -lb hamburger? _____ oz | ⑰ There are 30 students in a math class with an average weight of 92 lb per student.
A. What is the combined weight of all the students in the class? _____ lb
B. How much more than a ton is this? _____ lb |
| ⑯ One dozen baseballs were packaged for mailing. Each ball weighed 5 oz and the box weighed 9 oz. Find the total weight of the package in pounds and ounces. _____ lb _____ oz | |

TH 4;5	AT 7	OP 2;10	EB 44	AD 6,000	TR 760	YP 2,400	OT 2;1,600
LO 163	GR 4	EW 7;2	IT 9,000	ON 6;4	TO 80	ST 2,760	RO 400
SO 3	NG 3;800	BE 32,000	PA 56	GE 8	ER 28,000	EN 5	UP 2,700

--	--	--	--	--	--	--	--	--	--	--	--	--	--	--	--	--	--	--	--

Why Couldn't the Astronaut Make Cinnamon Toast?



Do each exercise and find your answer in the set of answers to the right. Write the letter of the answer in each box containing the number of the exercise. If the answer has a ●, shade in each box containing that exercise number.

I. Complete each statement.

- ① 6 gal 1 qt = _____ qt ② $5\frac{1}{2}$ pt = _____ c ③ 2 lb 6 oz = _____ oz ④ $2\frac{1}{4}$ T = _____ lb ⑤ 10 c = _____ fl oz ⑥ 3 qt = _____ fl oz ⑦ 88 oz = _____ lb _____ oz ⑧ 100,000 lb = _____ T ⑨ 15 qt = _____ gal _____ qt ⑩ 32 fl oz = _____ pt
- ⑪ U 2 ⑫ H 50
 ⑬ T 80 ⑭ S 11
 ⑮ R 5;8 ⑯ ● 144
 ⑰ K 30 ⑱ A 96
 ⑲ I 4,500 ⑳ J 4;2

II. Solve.

- ⑪ There are 2 tablespoons in a fluid ounce. How many tablespoons are in a cup? _____ tbs
 ⑫ For the big family picnic, Mr. Lincoln rented a huge jug and filled it with 20 gal of lemonade. If each person drank 1 pt, how many people could be served? _____
 ⑬ Apple juice is sold in a 1-gal jug for \$3.30. It is also sold in individual 8-oz cartons for 40¢ a carton. How much more per gallon do you pay by buying the individual cartons? \$ _____
- ⑭ Linda Kuerth set a record by eating 23 frankfurters in 3 min 10 s. If each frankfurter weighed 2 oz, find the total amount she ate in pounds and ounces. _____ lb _____ oz
 ⑮ According to one study, the average American teenager eats 1,817 lb of food a year. How much less than a ton is this? _____ lb
 ⑯ In a recent year gold was worth \$500 an ounce. If you weighed 100 lb and were "worth your weight in gold," how much would you be worth? \$ _____

Answers 11 – 16:

- ⑮ N 3;4 ⑯ B 600,000
 ⑰ E 3.10 ⑱ C 183
 ⑲ W 16 ⑳ O 2;14
 ㉑ ● 153 ㉒ G 12
 ㉓ D 150 ㉔ P 800,000
 ㉕ F 2.80 ㉖ ● 160

8	15	13	11	6	2	13	14	12	3	16	9	15	5	15	9	1	13	12	10	5	15	7	13	2	16	4	14	15
---	----	----	----	---	---	----	----	----	---	----	---	----	---	----	---	---	----	----	----	---	----	---	----	---	----	---	----	----

What Job Does the Buttermilk Biscuit Have in the Movie?

Do each exercise and find your answer in the appropriate answer box. Write the letter of the answer in the box containing the number of the exercise.

①
$$\begin{array}{r} 3 \text{ h } 45 \text{ min} \\ + 1 \text{ h } 30 \text{ min} \\ \hline \end{array}$$

②
$$\begin{array}{r} 9 \text{ min } 20 \text{ s} \\ + 4 \text{ min } 10 \text{ s} \\ \hline \end{array}$$

③
$$\begin{array}{r} 7 \text{ h } 10 \text{ min} \\ - 2 \text{ h } 50 \text{ min} \\ \hline \end{array}$$

④
$$\begin{array}{r} 8 \text{ min} \\ - 5 \text{ min } 25 \text{ s} \\ \hline \end{array}$$

⑤
$$\begin{array}{r} 6 \text{ ft } 4 \text{ in.} \\ + 9 \text{ ft } 7 \text{ in.} \\ \hline \end{array}$$

⑥
$$\begin{array}{r} 4 \text{ ft } 9 \text{ in.} \\ + 3 \text{ ft } 8 \text{ in.} \\ \hline \end{array}$$

⑦
$$\begin{array}{r} 12 \text{ yd } 2 \text{ ft} \\ + 5 \text{ yd } 2 \text{ ft} \\ \hline \end{array}$$

⑧
$$\begin{array}{r} 50 \text{ yd} \\ - 8 \text{ yd } 1 \text{ ft} \\ \hline \end{array}$$

⑨
$$\begin{array}{r} 1 \text{ c } 2 \text{ fl oz} \\ + 2 \text{ c } 5 \text{ fl oz} \\ \hline \end{array}$$

⑩
$$\begin{array}{r} 7 \text{ gal } 3 \text{ qt} \\ + 6 \text{ gal } 3 \text{ qt} \\ \hline \end{array}$$

⑪
$$\begin{array}{r} 3 \text{ qt } 1 \text{ pt} \\ + 5 \text{ qt } 1 \text{ pt} \\ \hline \end{array}$$

⑫
$$\begin{array}{r} 20 \text{ gal} \\ - 4 \text{ gal } 1 \text{ qt} \\ \hline \end{array}$$

⑬
$$\begin{array}{r} 8 \text{ lb } 9 \text{ oz} \\ + 30 \text{ lb } 9 \text{ oz} \\ \hline \end{array}$$

⑭
$$\begin{array}{r} 9 \text{ lb} \\ - 2 \text{ lb } 10 \text{ oz} \\ \hline \end{array}$$

⑮
$$\begin{array}{r} 4 \text{ T } 1,500 \text{ lb} \\ + 7 \text{ T } 800 \text{ lb} \\ \hline \end{array}$$

⑯
$$\begin{array}{r} 6 \text{ lb } 8 \text{ oz} \\ - 5 \text{ lb } 12 \text{ oz} \\ \hline \end{array}$$

⑰ To power an experimental car, Willy Messerschmitt mixed 12 gal 3 qt of gasoline with 4 gal 2 qt of ethyl alcohol. How much fuel did this make?

⑱ The average 12-year-old in the U.S. weighs 85 lb 12 oz. The average 14-year-old weighs 108 lb 2 oz. How much weight does the average person gain during these two years?

Answers 1 – 9:

Ⓐ 15ft 11 in.

Ⓒ 3 min 5 s

Ⓘ 13 min 30 s

Ⓓ 8 ft 5 in.

Ⓝ 41 yd 2 ft

Ⓔ 3 c 7 fl oz

Ⓑ 7 ft 6 in.

Ⓙ 5 h 15 min

Ⓞ 2 min 35 s

ⓕ 40 yd 1 ft

Ⓢ 18 yd 1 ft

ⓔ 4 h 20 min

Ⓟ 4 c 5 fl oz

Answers 10 – 18:

Ⓡ 17 gal 1 qt

Ⓔ 15 gal 3 qt

Ⓘ 39 lb 2 oz

Ⓟ 21 lb 10 oz

Ⓡ 13 T 700 lb

ⓗ 12 T 300 lb

ⓗ 14 gal 2 qt

Ⓓ 22 lb 6 oz

Ⓓ 12 oz

Ⓖ 9 qt

Ⓚ 16 gal 2 qt

Ⓢ 7 lb 2 oz

Ⓓ 6 lb 6 oz

10	3	13	7	1	15	9	18	12	5	16	2	8	11	17	4	14	6
----	---	----	---	---	----	---	----	----	---	----	---	---	----	----	---	----	---

What Does a Cat Need to Play Baseball?

For each exercise, circle the letter of the correct choice. Write this letter in the box containing the number of the exercise.

2	8	4	6	1	9	5	3	7
---	---	---	---	---	---	---	---	---

- Which of the following is not a point on \overleftrightarrow{AC} ?
 (Y) B (R) D (V) A
- Which of the following is not a correct name for this line?
 (A) \overleftrightarrow{PQ} (L) \overleftrightarrow{QP} (G) \overleftrightarrow{PQ}
- Which of the following is not the name of a segment in this figure?
 (O) \overline{RS} (T) \overleftrightarrow{ST} (H) \overline{TR}
- Which of the following is not the name of a ray in this figure?
 (W) \overrightarrow{EG} (S) \overrightarrow{FG} (U) \overrightarrow{FE}
- Which of the following is not a correct name for this angle?
 (I) $\angle ACB$ (Y) $\angle CBA$ (L) $\angle B$
- Which of the following is not the name of a line in this figure?
 (G) \overleftrightarrow{ZX} (R) \overleftrightarrow{XY} (K) \overleftrightarrow{YZ}
- Which of the following is a segment that has B as an endpoint?
 (N) \overline{CD} (C) \overline{AC} (T) \overline{CB}
- Which of the following is *not* the name of a ray in this figure?
 (H) \overrightarrow{MO} (S) \overrightarrow{LM} (P) \overrightarrow{KO}
- Which of the following is not a correct name for an angle in this figure?
 (M) $\angle H$ (A) $\angle LGHF$ (D) $\angle EHG$

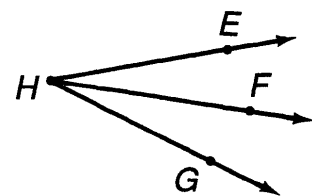
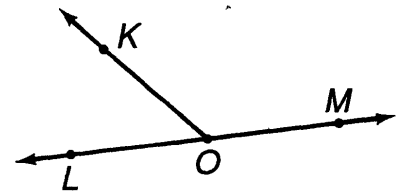
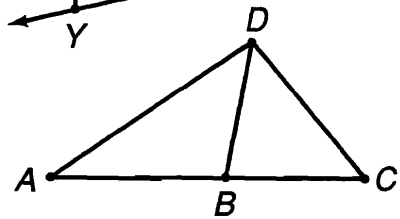
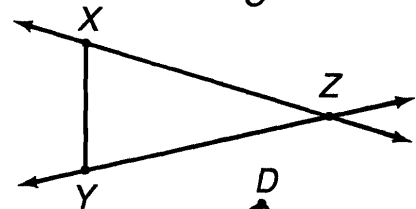
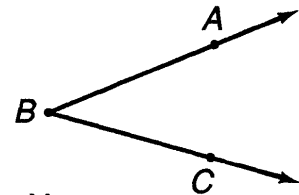
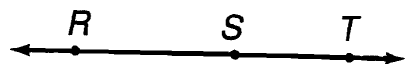
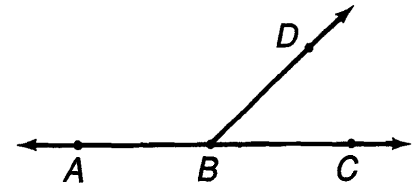

What Did Mrs. Claws Say During the Thunderstorm?

Find each answer at the bottom of the page and write the letter of the exercise above it.

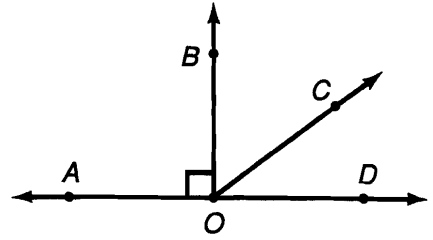

I. Complete each statement.

- (T) The figure formed by two rays from the same endpoint is an _____
- (O) The intersection of the two sides of an angle is called its _____
- (I) The vertex of $\angle COD$ in the drawing above is point _____
- (A) The instrument used to measure angles is called a _____
- (E) The basic unit in which angles are measured is the _____
- (O) $\angle AOB$ has a measure of 90° and is called a _____ angle.
- (A) An angle whose measure is between 0° and 90° is an _____ angle.
- (T) Two acute angles in the figure are $\angle BOC$ and _____
- (L) An angle whose measure is between 90° and 180° is an _____ angle.
- (N) An obtuse angle in the figure is _____

II. Give the measure of each angle.

- (A) $\angle RQS$ _____
- (T) $\angle LRQT$ _____
- (R) $\angle RQU$ _____
- (H) $\angle RQV$ _____
- (A) $\angle LRQW$ _____
- (K) $\angle LXQW$ _____
- (D) $\angle LXQT$ _____
- (R) $\angle UQV$ _____

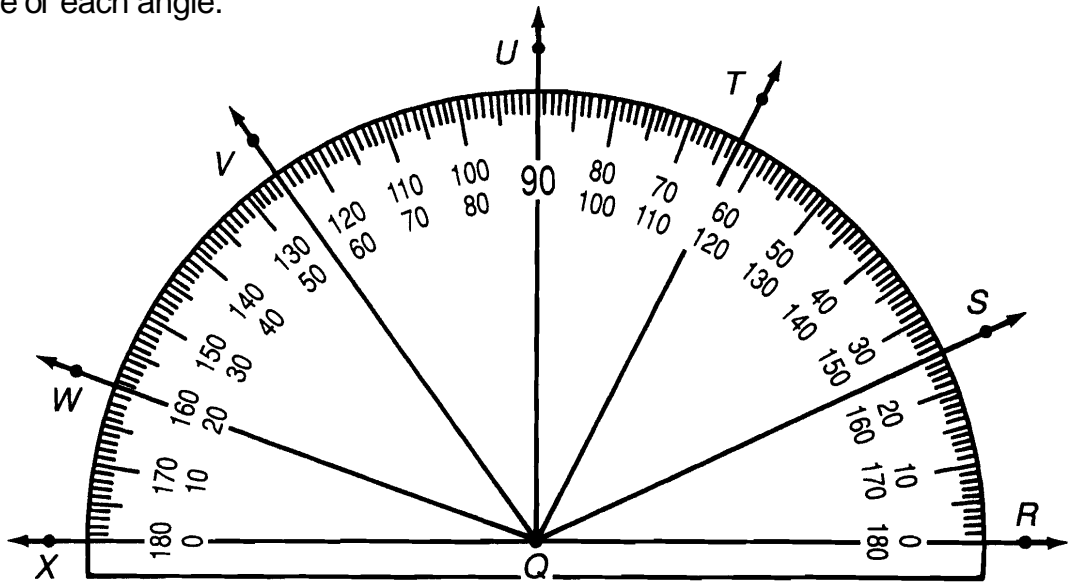

obtuse	vertex	right	20°	25°	angle	$\angle DOC$	125°	protractor	63°	35°	160°	O	$\angle AOC$	117°	degree	acute	90°
--------	--------	-------	------------	------------	-------	--------------	-------------	------------	------------	------------	-------------	---	--------------	-------------	--------	-------	------------

Why Did the Brontosaurus Need Band-Aids?

For each exercise, circle the letter of the best estimate. Write this letter in the box containing the number of the exercise.

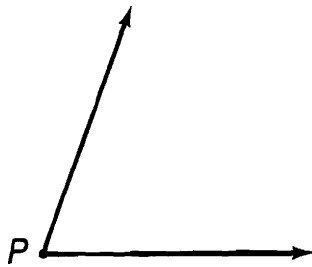

- ① $m\angle P$ is about
B 35° **S** 70°



- ② $m\angle X$ is about
T 65° **O** 30°

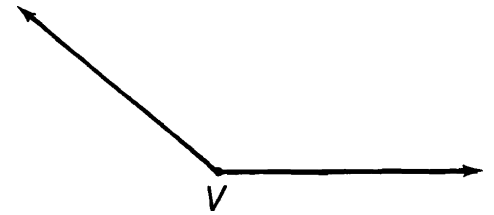

- ③ $m\angle V$ is about
E 140° **J** 95°



- ④ $m\angle G$ is about
L 55° **I** 25°

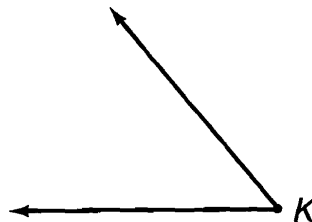

- ⑤ $m\angle K$ is about
O 50° **F** 80°



- ⑥ $m\angle W$ is about
R 155° **C** 110°

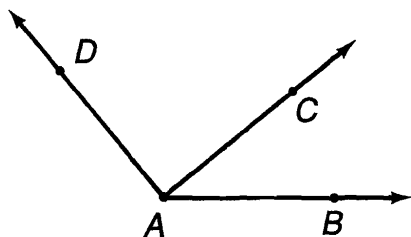

- ⑦ $m\angle BAC$ is about
S 40° **P** 15°

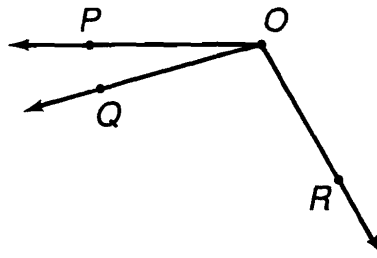

- ⑩ $m\angle POR$ is about
M 160° **F** 120°

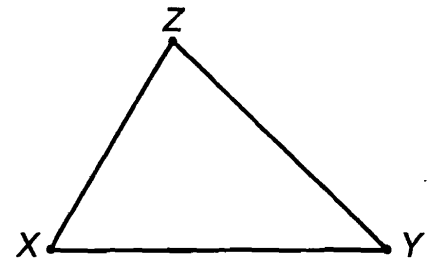

- ⑬ $m\angle X$ is about
P 35° **H** 60°

- ⑧ $m\angle CAD$ is about
U 65° **I** 90°

- ⑪ $m\angle POQ$ is about
V 40° **N** 15°

- ⑭ $m\angle Y$ is about
S 45° **L** 25°

- ⑨ $m\angle BAD$ is about
G 100° **O** 130°

- ⑫ $m\angle QOR$ is about
R 105° **B** 140°

- ⑮ $m\angle Z$ is about
D 75° **G** 40°

10	2	6	13	8	1	15	4	11	9	14	5	12	3	7
----	---	---	----	---	---	----	---	----	---	----	---	----	---	---

Books Never Written

Beginning Your Exercise Program by

57° 99° 119°

137° 173° 85° 99° 33°

Checking Your Homework by

33°

76°

156° 33° 47° 125° 28° 14°

How to Lead the Band by

38° 62° 33° 90° 28° 62°

41° 173° 119° 125°

ABOVE ARE THE TITLES OF THREE "BOOKS NEVER WRITTEN." TO DECODE THE NAMES OF THEIR AUTHORS:

Measure each angle below and find your answer in the code. Each time the answer appears in the code, write the vertex letter of that angle above it.

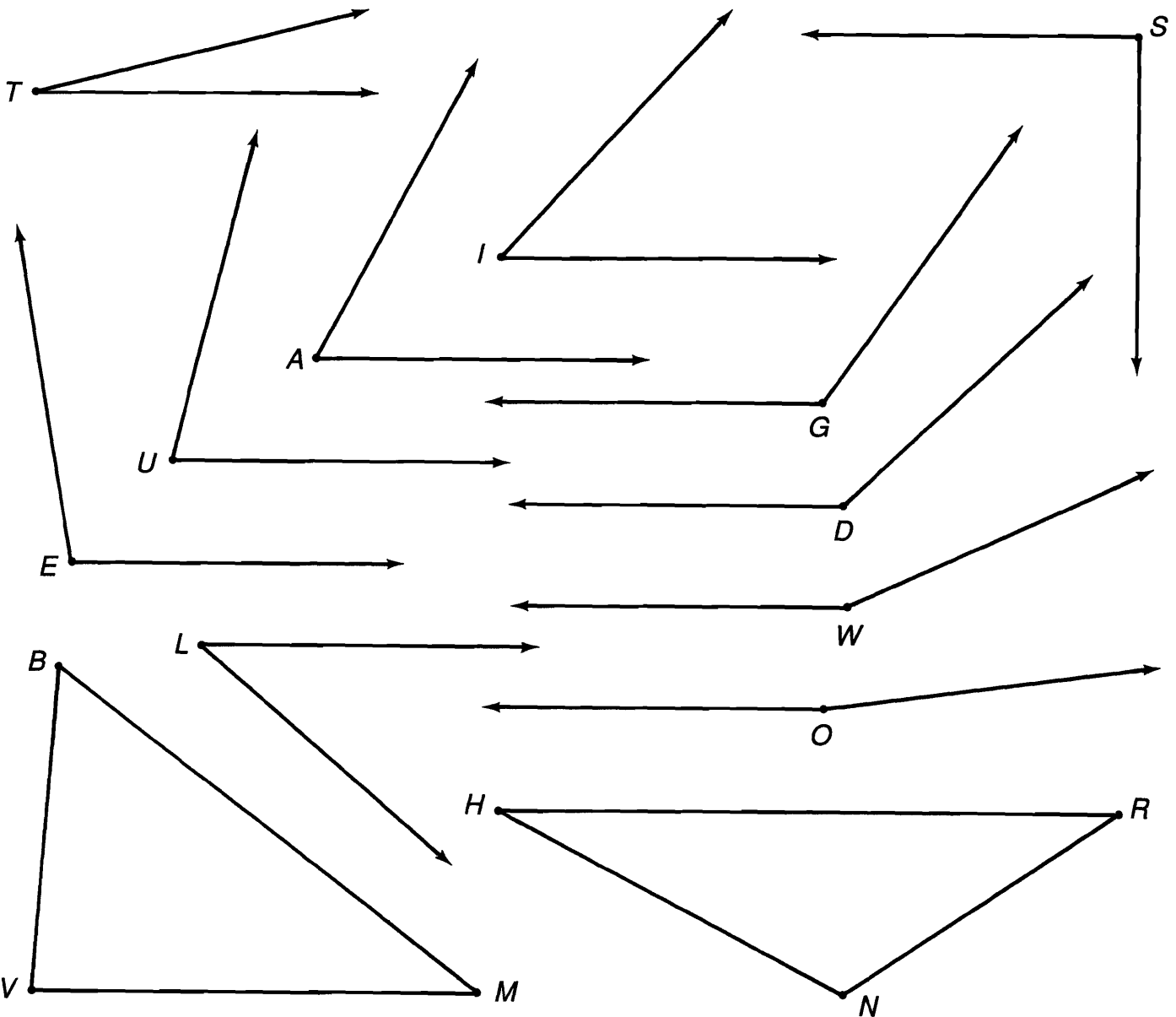

What Happens When Cupid Shoots an Arrow?



Use a protractor to construct the angles below. Each side you draw will pass through a number. Write the vertex letter of the angle in the box containing this number.

8 14 1 9 12

11 4 5

$E \xrightarrow{45^\circ} H \xrightarrow{60^\circ} O \xrightarrow{120^\circ}$

3 6 4 13 7 6

2 14 8 7 6

$E \xrightarrow{33^\circ} M \xrightarrow{97^\circ} S \xrightarrow{139^\circ}$

10 2 10

2 13 7 6

12

$O \xrightarrow{21^\circ} E \xrightarrow{72^\circ} S \xrightarrow{16^\circ}$

13 10 7 7 6

3 3

5 9

10

$N \xrightarrow{56^\circ} M \xrightarrow{108^\circ} R \xrightarrow{154^\circ}$

Why Is a Party Like Pouring Oil Into a Car?

Do each exercise and find your answer at the bottom of the page. Write the letter of the exercise in the box above or below the answer.

I. Find the measure of the angle that is complementary to the angle having the measure given.

- (E) 20° (H) 67° (S) 14° (E) 81° (T) 45°

II. Find the measure of the angle that is supplementary to the angle having the measure given.

- (R) 120° (E) 56° (I) 29° (U) 162° (H) 83°

III. Find the angle measure that is not given.

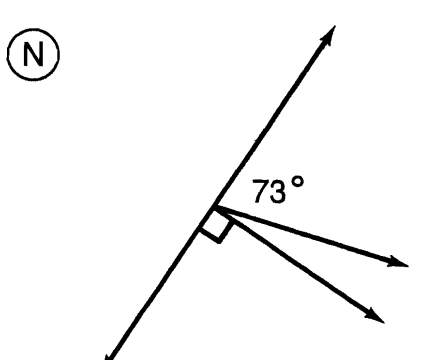
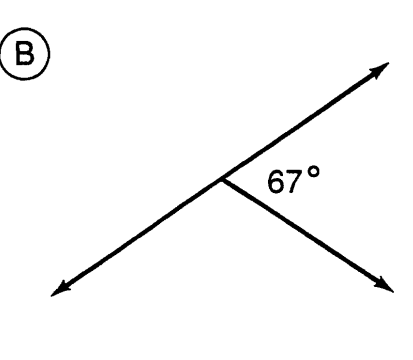
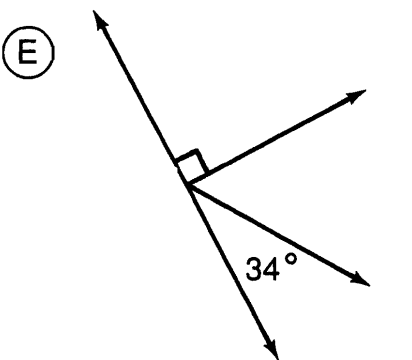
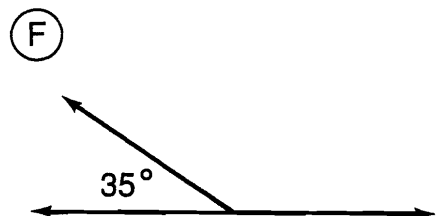
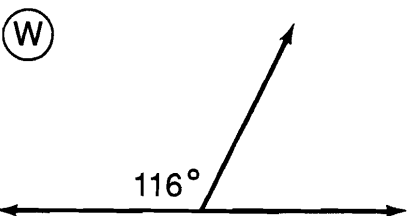
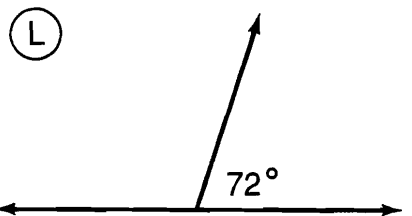
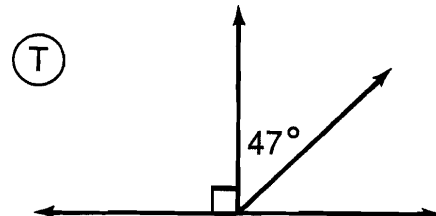
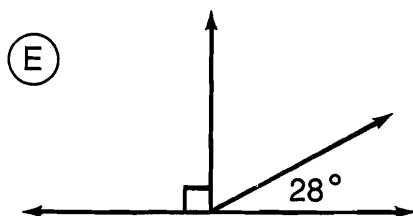
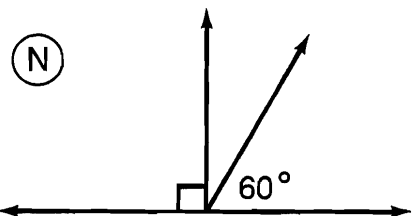

151° 76° 64° 56° 62° 45° 124° 145° 17° 70° 133° 9°

43° 125° 97° 60° 36° 23° 37° 18° 30° 108° 113°

How Did the Judge Find Out About the Rotten Milk?

Do each exercise and find your answer in the Code Key. Notice the letter next to the answer. Write this letter in the box containing the number for the exercise.



I. Complete each statement.

- ① Two angles are **complementary** if the sum of their measures is _____.
- ② Two angles are **supplementary** if the sum of their measures is _____.
- ③ The **complement** of a 30° angle has a measure of _____.
- ④ The **supplement** of a 65° angle has a measure of _____.

II. Find the measure of each numbered angle.

CODE KEY	
23°	D
30°	Q
36°	T
52°	A
60°	R
65°	U
80°	I
90°	O
100°	H
107°	S
115°	E
144°	W
180°	N

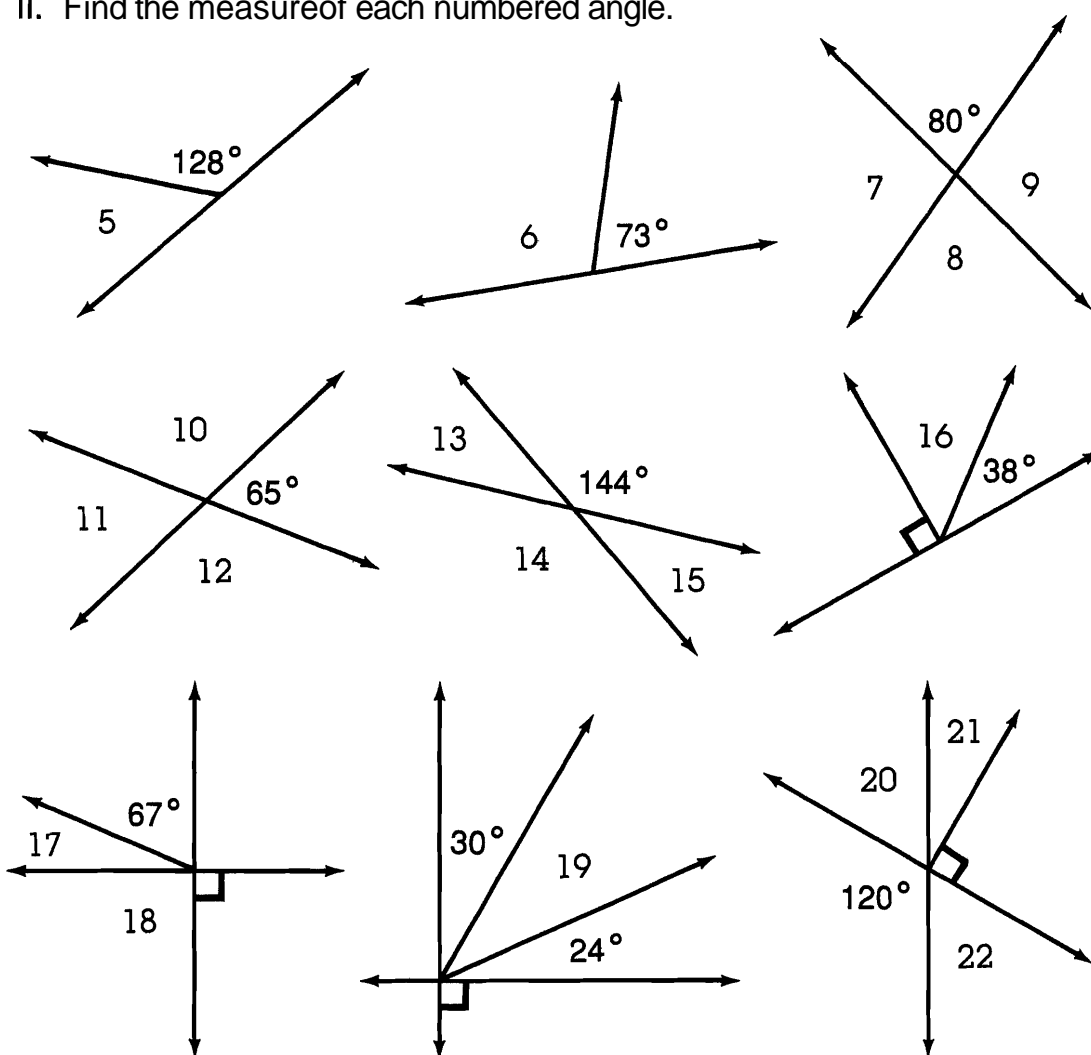

13	7	12	3	10	14	16	6	18	17	1	20	8	2	19	9	4	21	11	5	22	15
----	---	----	---	----	----	----	---	----	----	---	----	---	---	----	---	---	----	----	---	----	----

What Is The Biggest Problem of Miners?

1	2	3	4	5	6	7	8	9	10	11	12	13	14	15	16	17	18
---	---	---	---	---	---	---	---	---	----	----	----	----	----	----	----	----	----

Circle the number-letter pair of each TRUE statement. For these pairs, write the letter in the matching numbered box at the right.

I. Use the figure below, in which $\overleftrightarrow{EF} \perp \overleftrightarrow{BH}$. You should find 11 true statements.

7-E \overleftrightarrow{EF} intersects \overleftrightarrow{AD} at C.

11-O $\overleftrightarrow{EB} \perp \overleftrightarrow{AC}$

2-H $\overleftrightarrow{FC} \parallel \overleftrightarrow{HG}$

17-E $\overleftrightarrow{HC} \perp \overleftrightarrow{DB}$

1-T $\overleftrightarrow{EB} \parallel \overleftrightarrow{CH}$

3-A $\overleftrightarrow{BG} \perp \overleftrightarrow{CH}$

16-S $\overleftrightarrow{CF} \parallel \overleftrightarrow{BE}$

12-A $\angle EBC$ is a right angle.

18-G $\angle DCE$ is a right angle.

3-E $m\angle HCB = 90^\circ$.

8-T $\angle FCH$ is an acute angle.

16-E $\angle ECH$ is an obtuse angle.

14-P $\angle ABE$ is an acute angle.

4-Y Perpendicular lines intersect to form right angles.

18-T Parallel lines never intersect.

6-L $m\angle DCH = m\angle EBH$

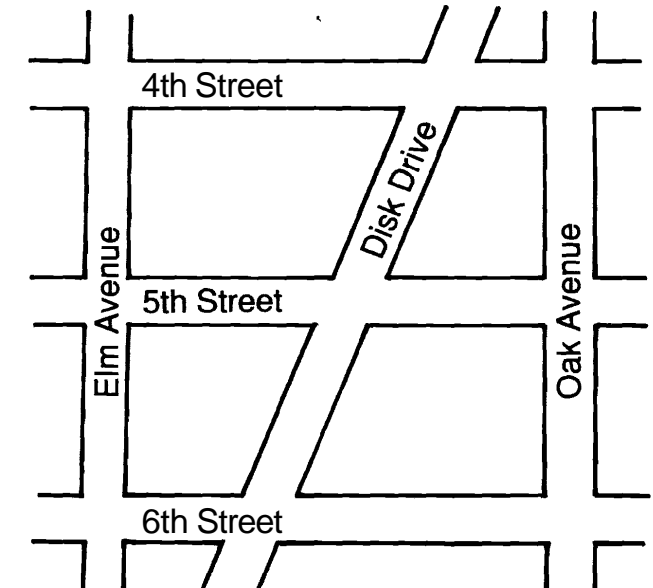
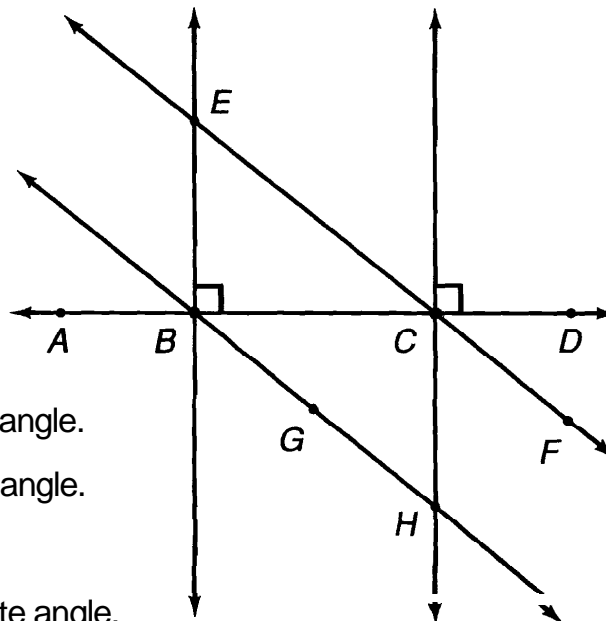

II. Use the figure above. You should find 4 true statements.

- 13-L 5th Street is parallel to 6th Street.
- 6-G 6th Street is perpendicular to Elm Avenue.
- 10-S Elm Avenue is parallel to Disk Drive.
- 15-F 4th Street and Oak Avenue intersect to form right angles.
- 9-N Elm Avenue is perpendicular to Oak Avenue.
- 10-C Elm Avenue is parallel to Oak Avenue.

Why Couldn't the Two Elephants Go Swimming Together?

Give the measure of each numbered angle. Find your answer in the Code Key and notice the letter next to it. Write this letter in the box containing the number of the angle.
(Assume that lines in each figure that do not intersect are parallel.)

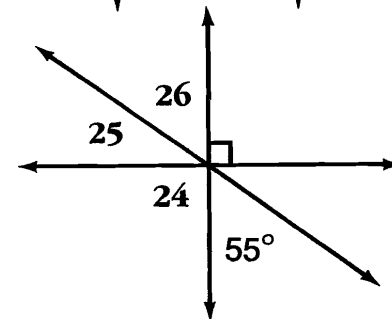
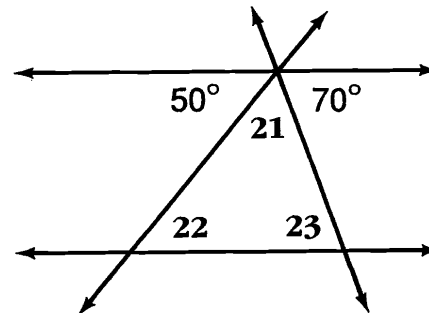
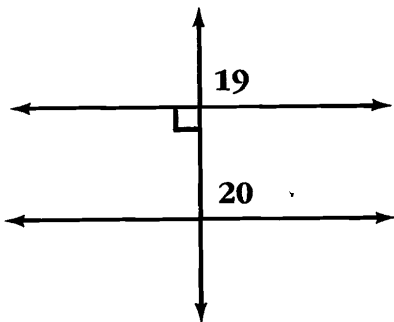
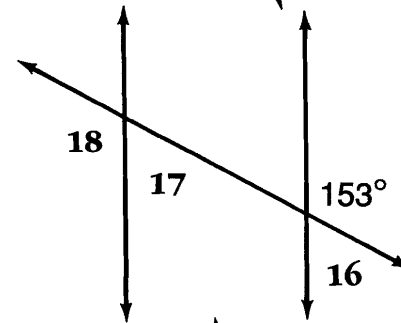
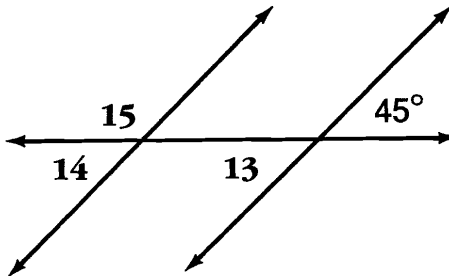
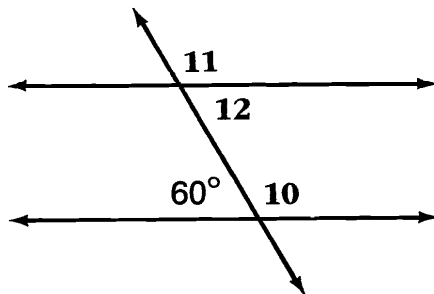
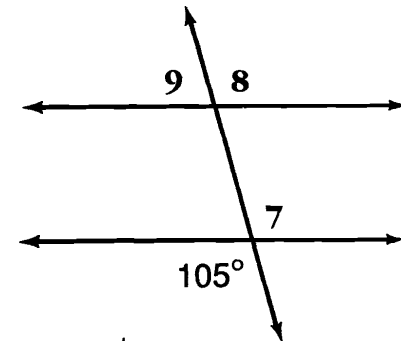
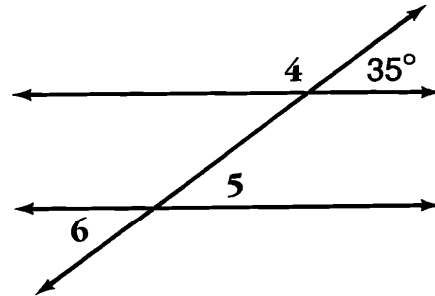
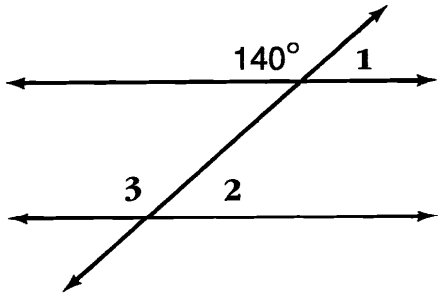

CODE KEY	
27°	A
35°	O
40°	R
45°	Y
50°	I
55°	P
60°	T
70°	U
75°	F
90°	N
105°	H
120°	E
135°	K
140°	L
145°	S
153°	D

12	7	10	14	8	16	18	6	20	3	13	25	19	11	26	17	22	1	5	9	21	2	23	24	15	4
----	---	----	----	---	----	----	---	----	---	----	----	----	----	----	----	----	---	---	---	----	---	----	----	----	---

What Did the Boy Candy Say to the Girl Candy?

Do each exercise and find your answer in the set of answers to the right. Write the letter of the answer in each box containing the number of the exercise. If the answer has a ●, shade in each box containing that exercise number.

I. Classify each triangle two ways.

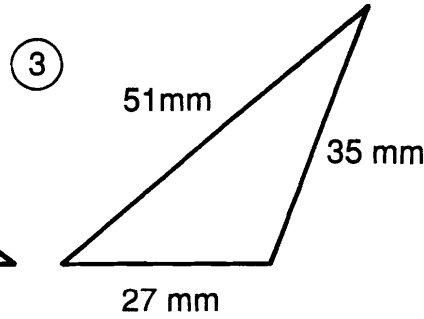
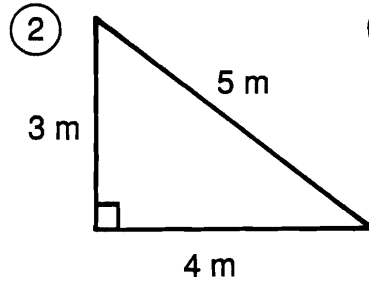
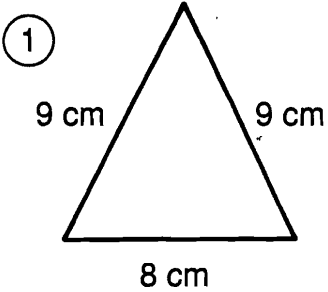

- Ⓢ acute; scalene
- Ⓛ acute; isosceles
- ⓗ acute; equilateral
- Ⓞ right; scalene
- Ⓜ right; isosceles
- Ⓐ obtuse; scalene
- Ⓕ obtuse; isosceles

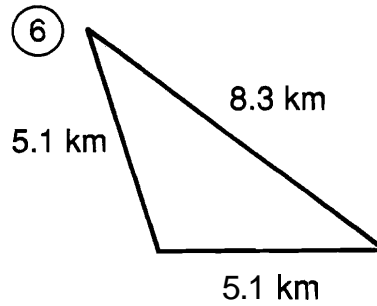
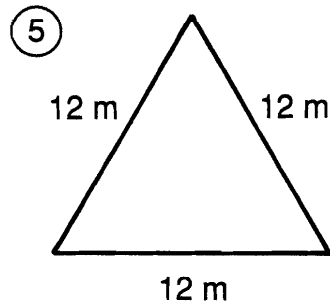
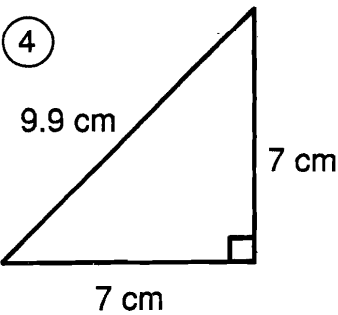

II. Find the measure of the third angle in each triangle.

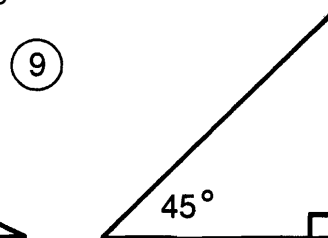
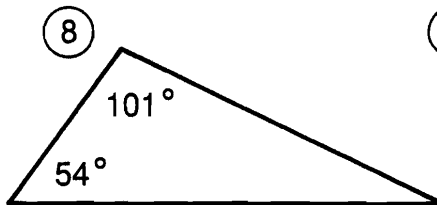
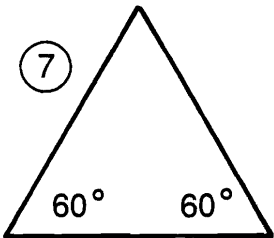

- Ⓡ 25°
- 116°
- ⓔ 56°
- Ⓣ 127°
- Ⓦ 60°
- Ⓝ 30°
- 58°
- Ⓒ 45°
- Ⓛ 40°

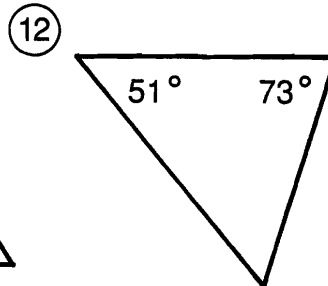
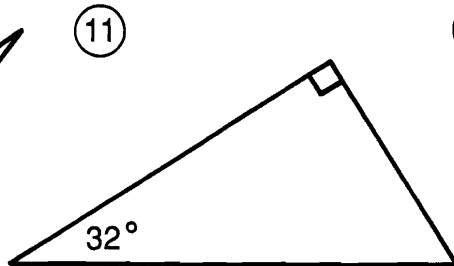
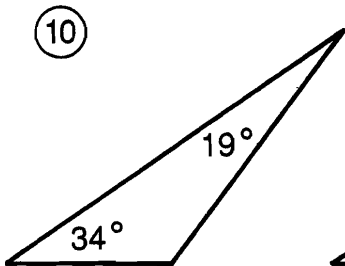

⑬ Two angles of a triangle have equal measures. If the third angle measures 120° , what is the measure of each of the equal angles?

7	12	11	3	8	12	11	4	1	13	10	11	6	2	8	11	12	3	9	5	11	2	10	5	12	8
---	----	----	---	---	----	----	---	---	----	----	----	---	---	---	----	----	---	---	---	----	---	----	---	----	---

What Do You Get When You,,,

1. Cross two ducks with a match?

Answer: 37° 57° 99° 67° 104° 76° 59° 113° 42° 53° 67° 99° 18°

2. Cross a stick of dynamite with a lemon pie?

Answer: 113° 68° 63° 34° 34° 54° 38° 54° 67° 99° 57° 90° 36° 59° 67°

Find the angle measures indicated. Look for each answer in the code. Each time the answer appears, write the letter of the exercise above it.

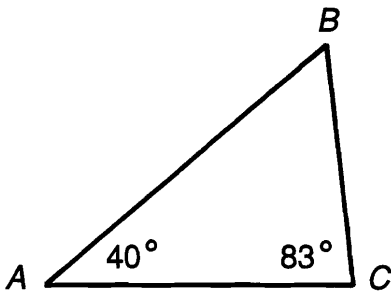

(I) $m\angle B =$

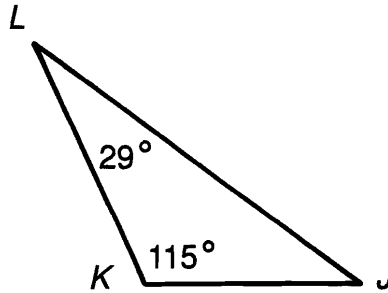

(G) $m\angle J =$

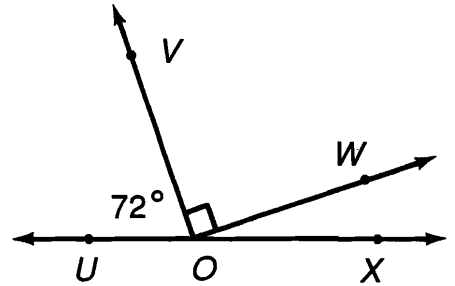

(S) $m\angle WOX =$

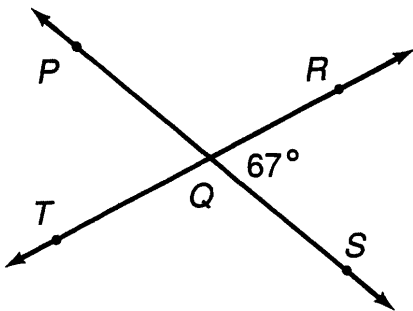

(A) $m\angle PQR =$

(E) $m\angle PQT =$

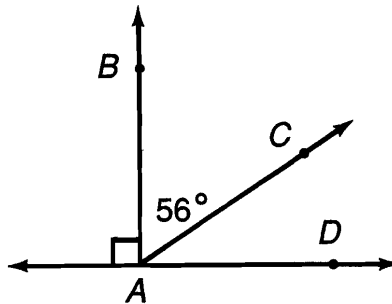

(N) $m\angle DAB =$

(O) $m\angle DAC =$

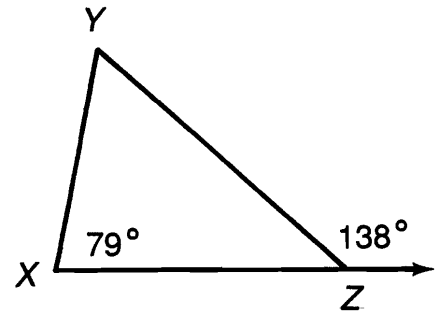

(C) $m\angle XZY =$

(U) $m\angle Y =$

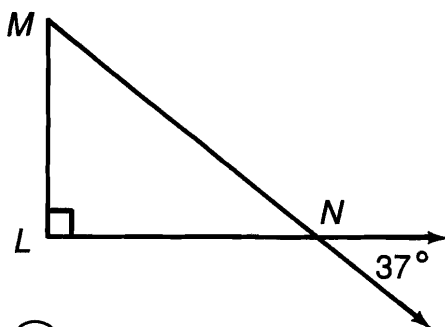

(F) $m\angle MNL =$

(K) $m\angle M =$

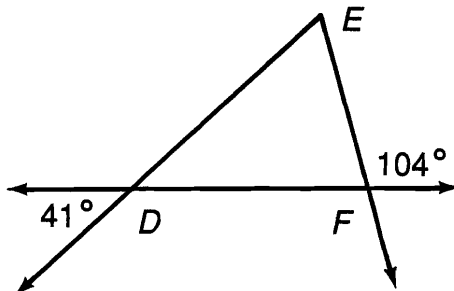

(Q) $m\angle EFD =$

(B) $m\angle E =$

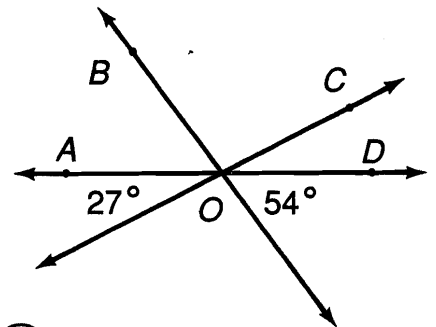

(M) $m\angle AOB =$

(R) $m\angle BOC =$

Daffynition Decoder

For each exercise, find the angle measure indicated. Look for each answer in the code. Each time the answer appears, write the letter of the exercise above it.

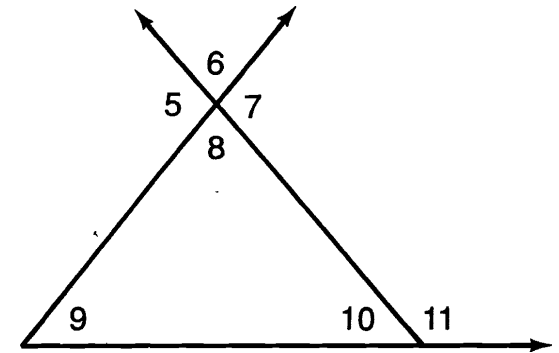
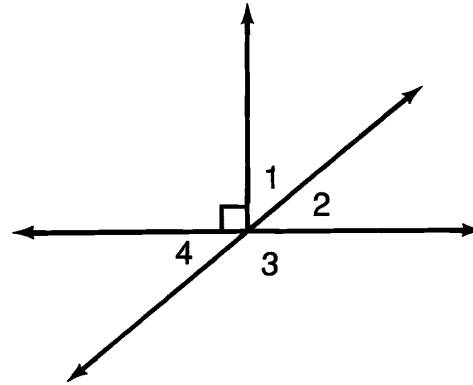

Warehouse:

105° 40° 36° 78° 151° 55° 45° 146° 36° 151° 105° 40° 135° 42° 34° 55° 146° 78°

Explain:

42° 55° 78° 146° 116° 56° 36° 74° 29° 34° 135° 100° 55° 56° 60° 56° 98° 135° 100°

- (H) If $m\angle 1 = 50^\circ$, then $m\angle 2 =$
- (F) If $m\angle 3 = 120^\circ$, then $m\angle 4 =$
- (O) If $m\angle 2 = 35^\circ$, then $m\angle 1 =$
- (E) If $m\angle 4 = 45^\circ$, then $m\angle 3 =$
- (B) If $m\angle 6 = 29^\circ$, then $m\angle 8 =$
- (Y) If $m\angle 6 = 29^\circ$, then $m\angle 5 =$
- (C) If $m\angle 5 = 116^\circ$, then $m\angle 7 =$
- (I) If $m\angle 8 = 82^\circ$, then $m\angle 7 =$
- (A) If $m\angle 11 = 144^\circ$, then $m\angle 10 =$

- (N) If $m\angle 8 = 78^\circ$ and $m\angle 9 = 60^\circ$, then $m\angle 10 =$
- (D) If $m\angle 9 = 47^\circ$ and $m\angle 10 = 33^\circ$, then $m\angle 8 =$
- (U) If $m\angle 10 = 45^\circ$ and $m\angle 8 = 90^\circ$, then $m\angle 9 =$
- (M) If $m\angle 6 = 66^\circ$ and $m\angle 9 = 40^\circ$, then $m\angle 10 =$
- (T) If $m\angle 11 = 130^\circ$ and $m\angle 9 = 52^\circ$, then $m\angle 8 =$
- (W) If $m\angle 8 = 81^\circ$ and $m\angle 9 = 24^\circ$, then $m\angle 11 =$
- (R) If $m\angle 2 = 56^\circ$, then $m\angle 4 =$
- (L) If $m\angle 1 = 56^\circ$, then $m\angle 4 =$
- (S) If $m\angle 1 = 56^\circ$, then $m\angle 3 =$

Can a Polar Bear Go On a Safari?

Write the name that best describes each quadrilateral. (Put each quadrilateral in the smallest or most exact class to which it belongs.) Write the letter of the exercise in the box containing the number of the answer.

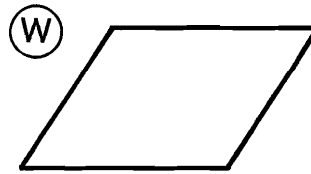
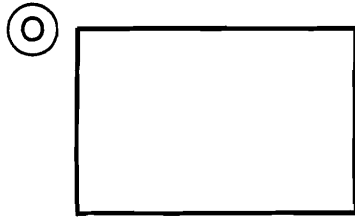
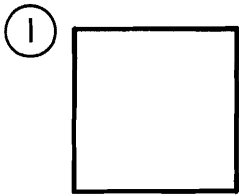

- (2) rectangle
- (15) trapezoid
- (10) square
- (18) parallelogram

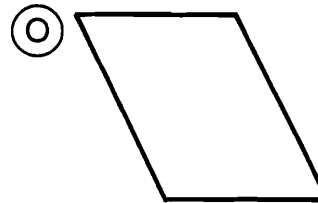
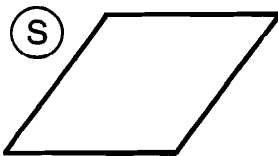
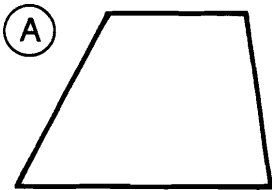

- (9) rectangle
- (6) trapezoid
- (17) parallelogram
- (11) rhombus

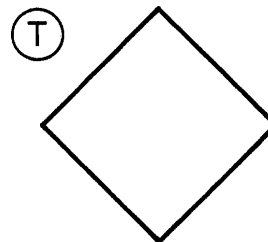
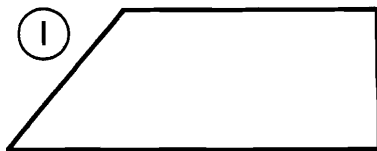
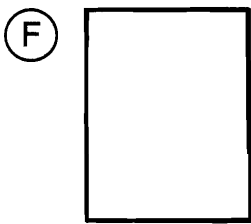

- (3) square
- (13) trapezoid
- (4) parallelogram
- (7) rectangle

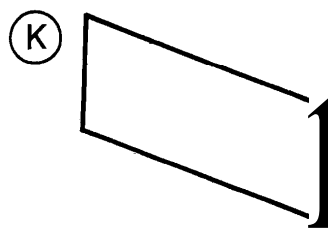
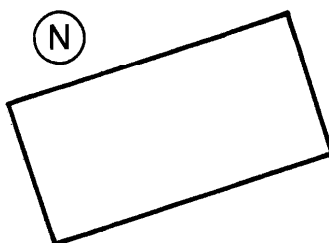
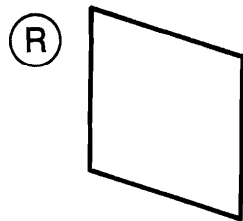

- (15) parallelogram
- (1) rectangle
- (9) rhombus
- (12) trapezoid

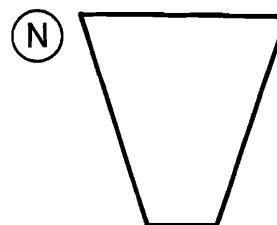
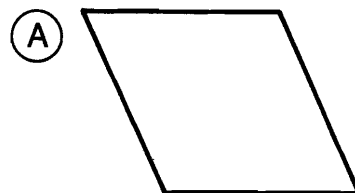
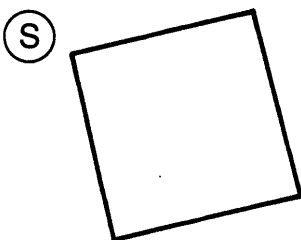

- (16) trapezoid
- (5) square
- (14) rectangle
- (8) rhombus

1	2	3	4	5	6	7	8	9	10	11	12	13	14	15	16	17	18
---	---	---	---	---	---	---	---	---	----	----	----	----	----	----	----	----	----

Why Was Cinderella Kicked Off the Baseball Team?

For each exercise, circle the letter of each figure that belongs in the category named. Arrange these letters to form a word. Then write this word on the line next to the name of the category.

(You may assume the following: sides that appear parallel are parallel; sides that appear perpendicular are perpendicular; sides that appear congruent are congruent.)

① quadrilaterals: _____

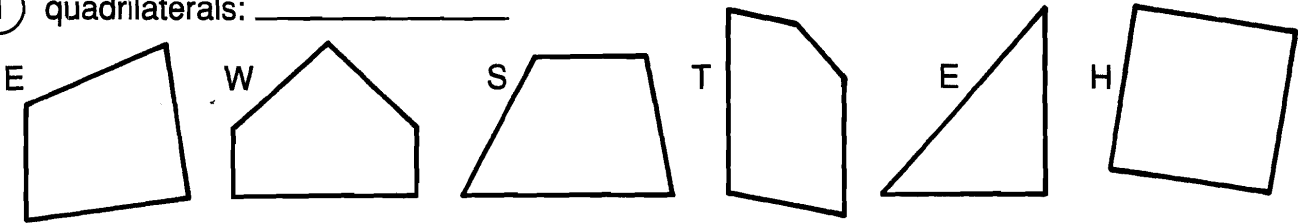

② parallelograms: _____

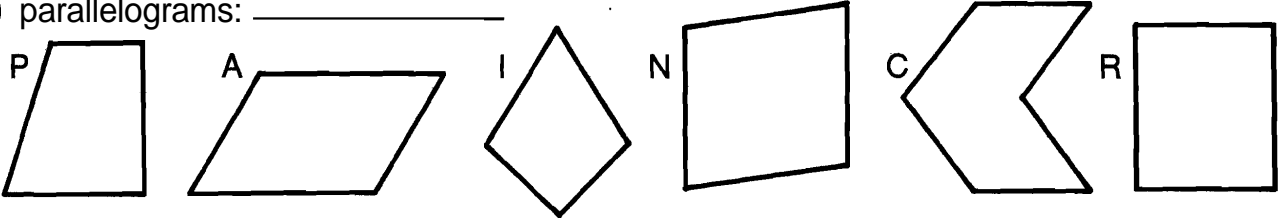

③ rectangles: _____

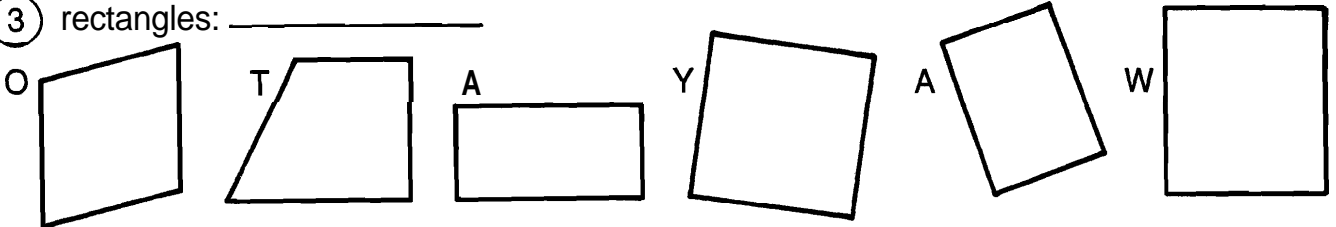

④ rhombuses: _____

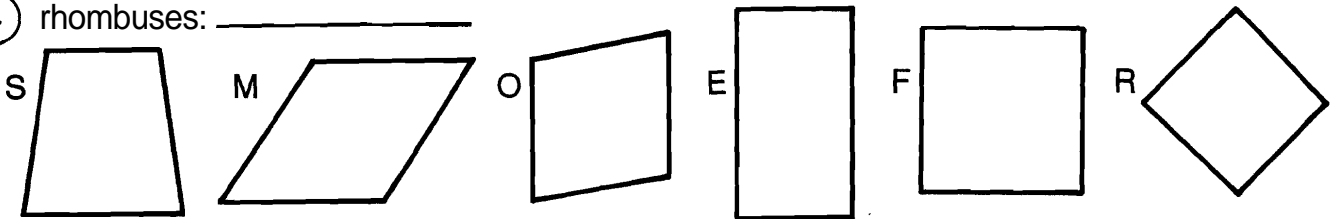

⑤ squares: _____

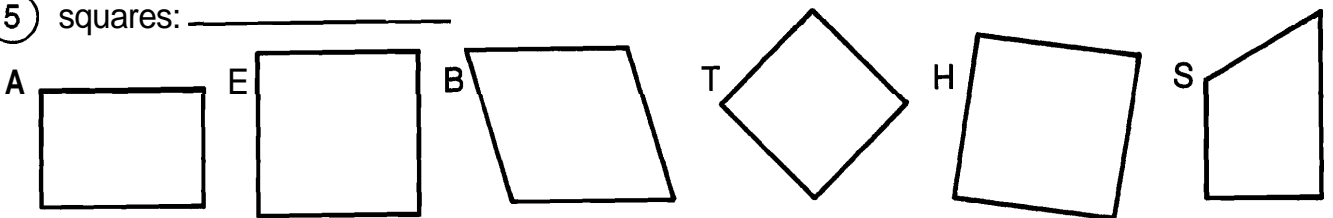

⑥ trapezoids: _____

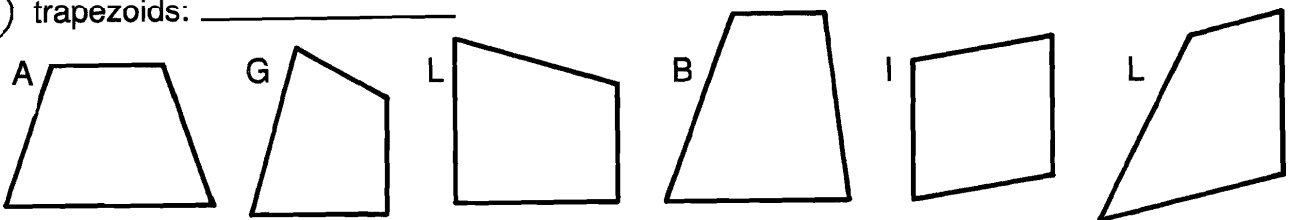

Why Didn't the Snobbish Potatoes Want Their Daughter to Marry a News Broadcaster?

Under each figure, circle the number-letter combination next to each word that correctly names the figure. Write the letter in the matching numbered box at the bottom of the page.



5-A parallelogram
16-0 rectangle
19-F square

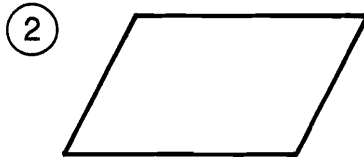

25-E parallelogram
13-1 rectangle
4-D rhombus

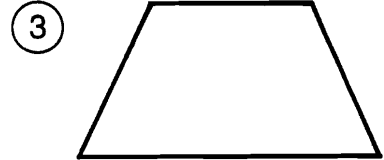

9-U quadrilateral
21-F parallelogram
1-H trapezoid

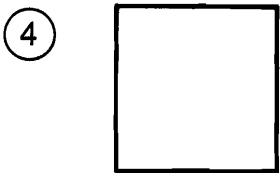

20-N parallelogram
11-T rectangle
23-A square

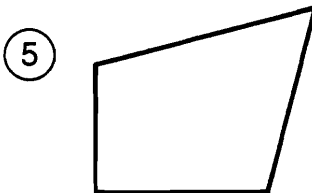

2-E quadrilateral
24-V parallelogram
8-P rhombus

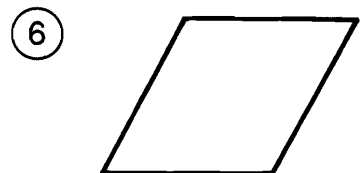

19-0 parallelogram
15-L rectangle
6-S rhombus

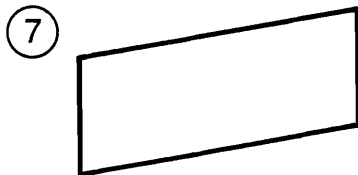

13-A quadrilateral
26-R parallelogram
7-N trapezoid

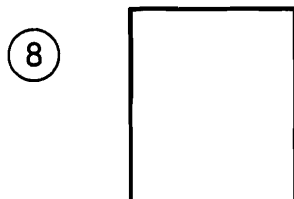

17-M rectangle
10-P square
14-S trapezoid

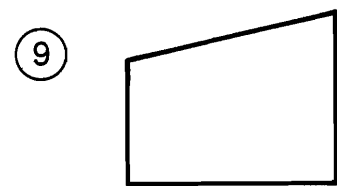

21-E parallelogram
18-1 rhombus
8-J trapezoid

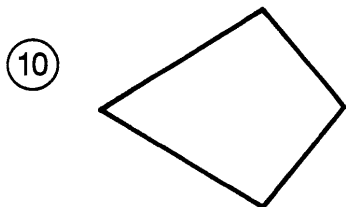

4-W quadrilateral
12-0 parallelogram
24-N trapezoid

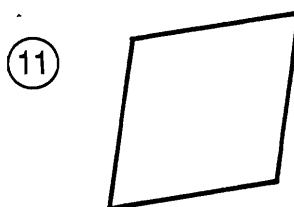

22-T quadrilateral
15-C rhombus
3-B square

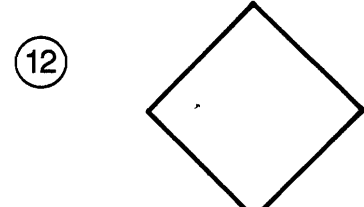

10-S rectangle
18-M rhombus
24-T square

1	2	3	4	5	6	7	8	9	10	11	12	13	14	15	16	17	18	19	20	21	22	23	24	25	26
---	---	---	---	---	---	---	---	---	----	----	----	----	----	----	----	----	----	----	----	----	----	----	----	----	----

Why Couldn't Orgo Buy a Round Trip Ticket?

Follow the directions for each section. Each exercise will give you a number-letter pair. Write the letter in the matching numbered box at the bottom of the page.

I. Find each pair of congruent figures. Use the number from one figure and the letter from the other.

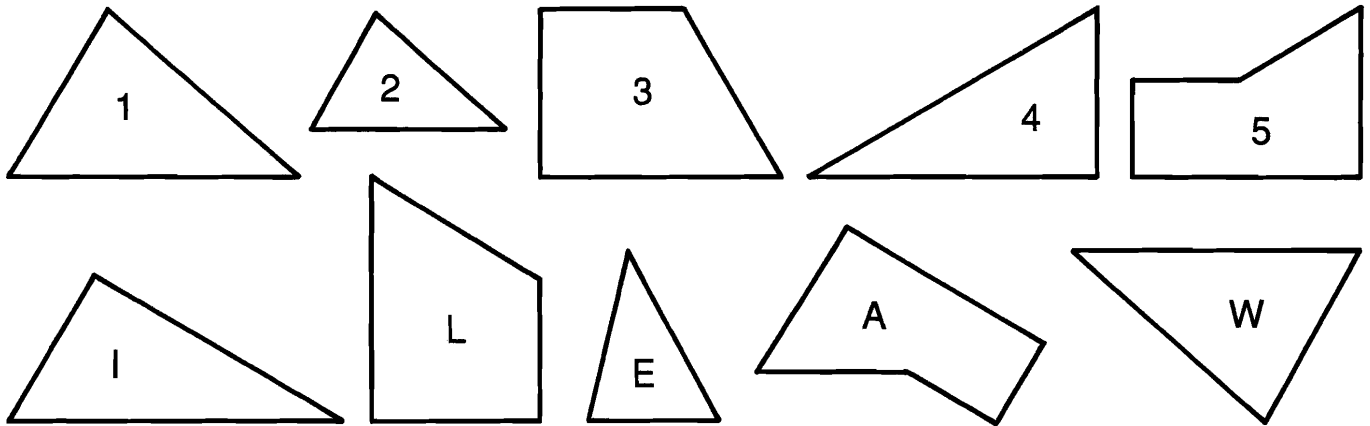

II. Complete each statement, then find your answer in the answer column. Use the number of the exercise and the letter of the answer.

$AABC \cong AEDF$

- ⑥ $\overline{AB} \cong$
- ⑨ $\angle A \cong$
- ⑦ $\overline{BC} \cong$
- ⑩ $\angle B \cong$
- ⑧ $\overline{AC} \cong$
- ⑪ $\angle C \cong$

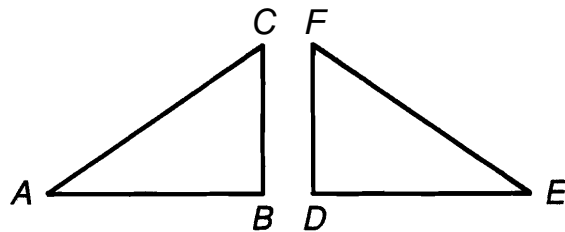

Answers 6 – 11:

- Ⓔ $\angle D$
- Ⓕ $\angle F$
- Ⓢ \overline{EF}
- Ⓣ \overline{DF}
- Ⓔ \overline{ED}
- Ⓤ $\angle E$

$ASKM \cong ANGJ$

- ⑫ $\overline{SK} \cong$
- ⑮ $\angle S \cong$
- ⑬ $\overline{KM} \cong$
- ⑯ $\angle K \cong$
- ⑭ $\overline{SM} \cong$
- ⑰ $\angle M \cong$

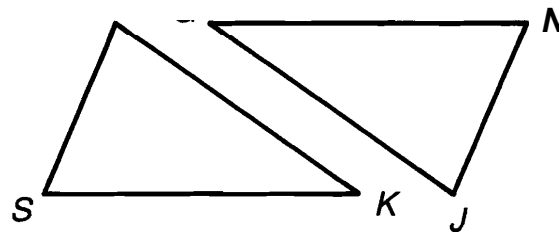

Answers 12 – 17:

- Ⓢ $\angle J$
- Ⓔ \overline{GJ}
- Ⓓ $\angle N$
- Ⓣ \overline{NJ}
- Ⓒ $\angle G$

$ARHX \cong ATYL$

- ⑱ $\overline{TY} \cong$
- ⑳ $\angle T \cong$
- ⑲ $\overline{YL} \cong$
- ㉑ $\angle Y \cong$
- ㉒ $\overline{TL} \cong$
- ㉓ $\angle L \cong$

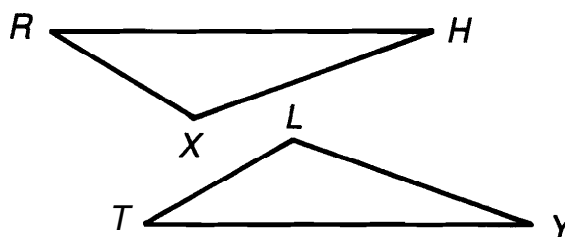

Answers 18 – 23:

- Ⓓ $\angle R$
- Ⓚ \overline{RX}
- Ⓔ \overline{RH}
- Ⓣ $\angle H$
- Ⓚ $\angle X$
- Ⓛ \overline{HX}

7	11	2	22	4	16	20	10	14	8	1	18	15	6	12	3	19	17	23	9	5	21	13
---	----	---	----	---	----	----	----	----	---	---	----	----	---	----	---	----	----	----	---	---	----	----

Does Any Animal Have More Than 9 Lives?

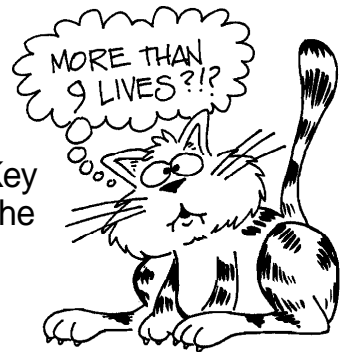

Give the angle measures indicated. Find each answer in the Code Key and notice the letter next to it. Write this letter in the box containing the number of the exercise.

$AABC \sim ADEF$

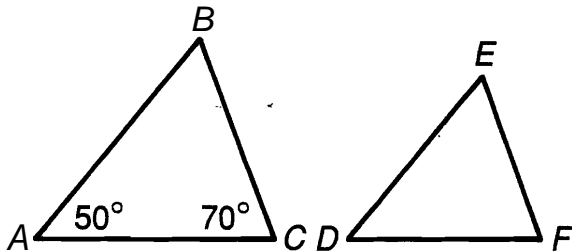

$AJKL \sim ARST$

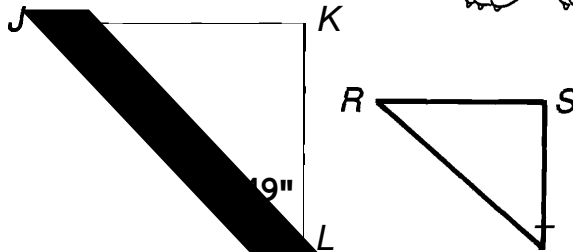

1. $m\angle B =$ 3. $m\angle D =$ 5. $m\angle J =$ 7. $m\angle S =$
 2. $m\angle E =$ 4. $m\angle F =$ 6. $m\angle T =$ 8. $m\angle R =$

Code Key	
24°	C
38°	Y
41°	O
46°	V
47°	G
49°	T
50°	E
60°	S
67°	A
70°	H
73°	F
75°	R
84°	N
90°	I
109°	K

$AXYZ \sim AHPV$

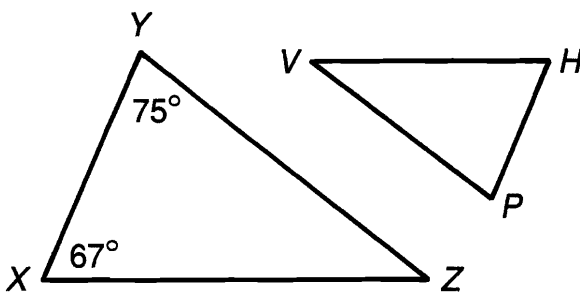

$AQGW \sim \triangle NMU$

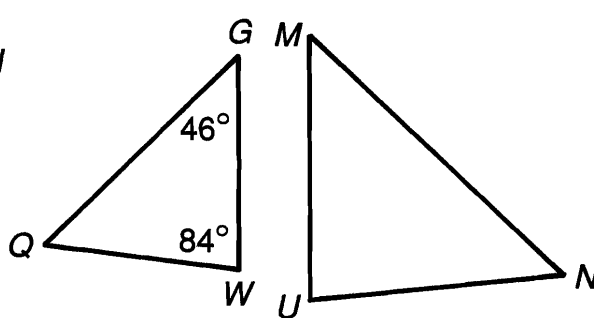

9. $m\angle Z =$ 11. $m\angle V =$ 13. $m\angle Q =$ 15. $m\angle U =$
 10. $m\angle H =$ 12. $m\angle P =$ 14. $m\angle M =$ 16. $m\angle N =$

$AEFG \sim \triangle HIG$

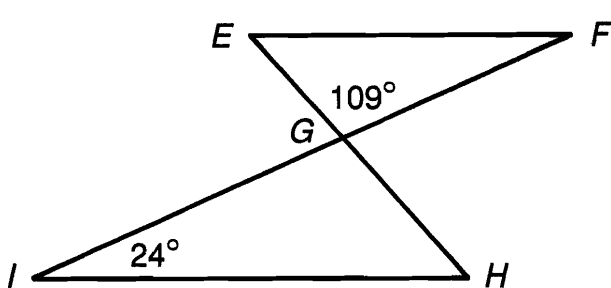

$ATLC \sim AOKC$

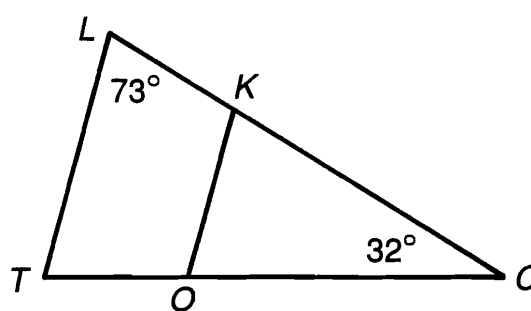

17. $m\angle IGH =$ 19. $m\angle F =$ 21. $m\angle T =$ 23. $m\angle OKC =$
 18. $m\angle H =$ 20. $m\angle E =$ 22. $m\angle KOC =$

11	13	2	23	12	8	20	1	19	22	5	10	17	16	14	3	21	9	15	7	18	4	6
----	----	---	----	----	---	----	---	----	----	---	----	----	----	----	---	----	---	----	---	----	---	---

What Did the Waitress Mean When She Yelled to the Cook: “1 + 1”?

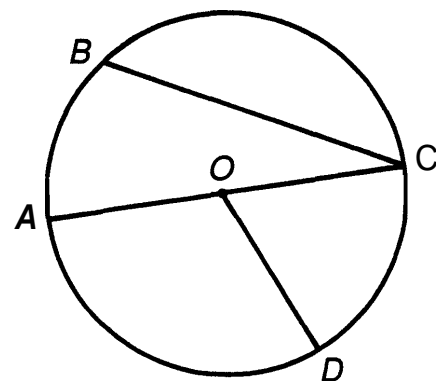

Fill in each blank with one of the answers at the bottom of the page. Then write the letter of the exercise above its correct answer.

The figure at the right is a circle with center at O .

- (E) The points on a circle are all the same distance from the _____
- (S) A line segment from the center to any point on the circle is a _____
- (U) A line segment with both endpoints on the circle is a _____
- (I) A chord that passes through the center of a circle is a _____
- (O) A diameter of the circle in the drawing above is the segment _____.
- (E) Which of the following is *not* a radius: \overline{OA} , \overline{OD} , or \overline{BC} ? _____
- (S) Which of the following is *not* a chord: \overline{BC} , \overline{OA} , or \overline{AC} ? _____
- (N) Part of a circle, such as between points B and C , is an _____
- (E) An angle whose vertex is at the center of a circle is a _____
- (P) Which of the following is *not* a central angle: $\angle AOD$, $\angle COD$, or $\angle BCA$? _____
- (S) Points A , B , C , and D are all the same _____ from point O .
- (O) If the length of \overline{AC} is 20 cm, then the length of \overline{OC} is _____
- (N) If the length of \overline{OA} is 20 cm, then the length of \overline{OD} is _____
- (W) If the length of \overline{OD} is 20 cm, then the length of \overline{AC} is _____
- (L) The length of a radius is _____ the length of a diameter.
- (T) The set of points in a plane at a fixed distance from a given point is a _____

10 cm	arc	center	ray	$\angle BCA$	half	chord	\overline{OA}	$\angle COD$	\overline{AC}	20 cm	central angle	\overline{OD}	diameter	distance	80 cm	radius	circle	\overline{BC}	40 cm
-------	-----	--------	-----	--------------	------	-------	-----------------	--------------	-----------------	-------	---------------	-----------------	----------	----------	-------	--------	--------	-----------------	-------

♥ *What Did the Secretary Say* ♥ *to Her Boy Friend?* ♥

For each exercise, circle the letter of each figure that is divided by a line of symmetry. Arrange these letters to form a word. Then write this word on the line next to the exercise number.

① _____

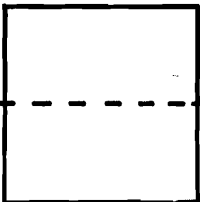
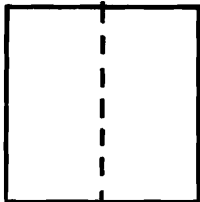
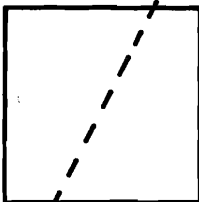
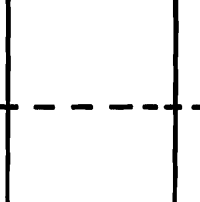
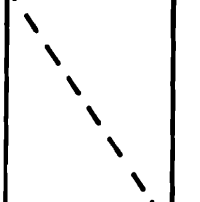
O  Y  E  U  T 

② _____

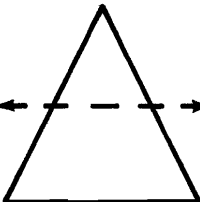
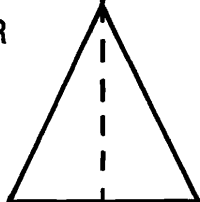
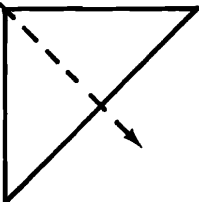
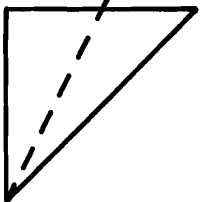
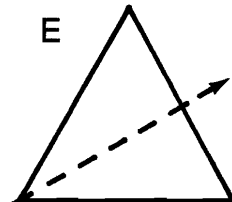
T  R  A  N  E 

③ _____

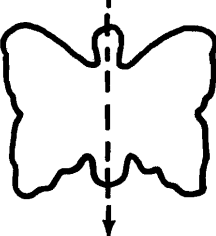
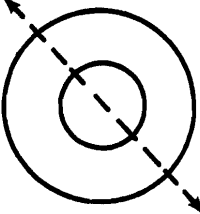
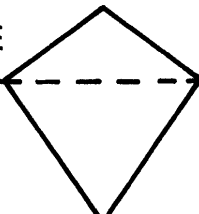
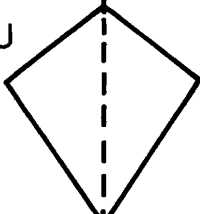
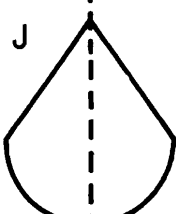
S  T  E  U  J 

④ _____

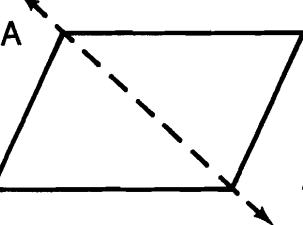
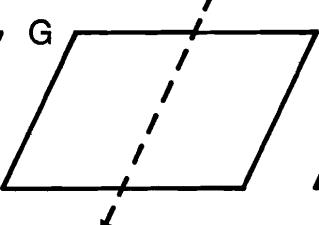
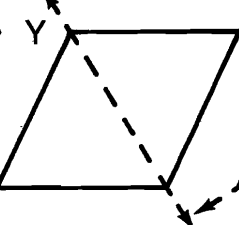
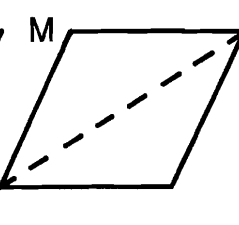
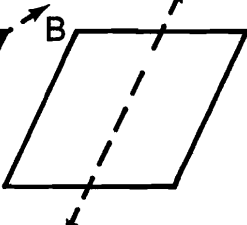
A  G  Y  M  B 

⑤ _____

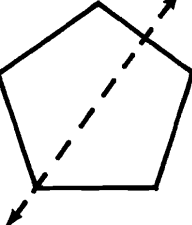
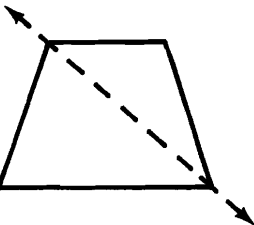
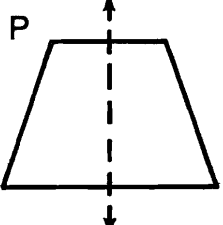
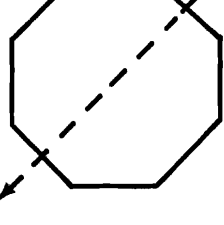
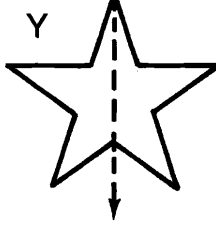
E  S  P  T  Y 

What Did the Taxi Driver Say About His Daughter?

Write the name that best describes the space figure. Then find your answer in the answer column. Write the letter of the answer in the box containing the number of the exercise.

6	4	9		2	1	1	5	7		10	1	12	8	3
---	---	---	--	---	---	---	---	---	--	----	---	----	---	---

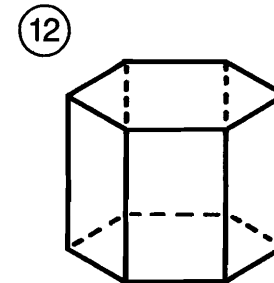
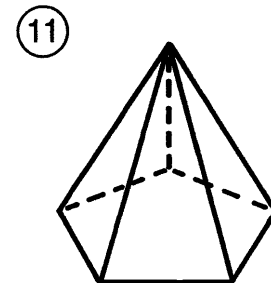
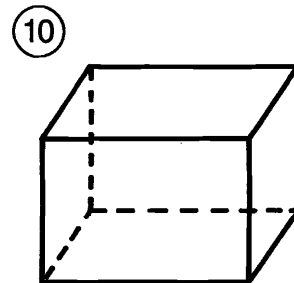
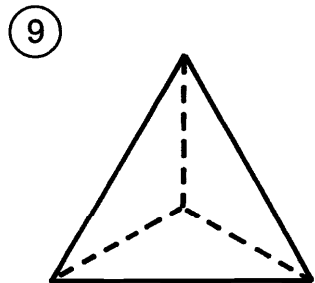
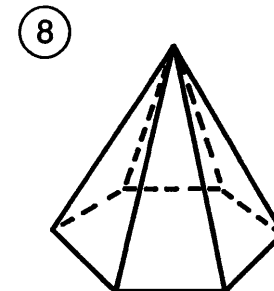
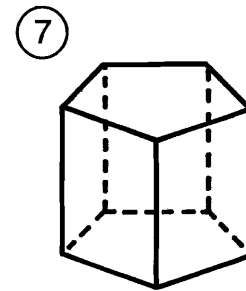
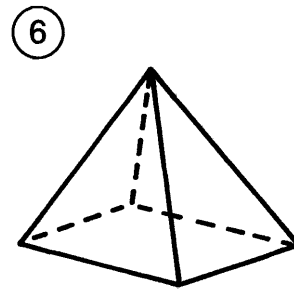
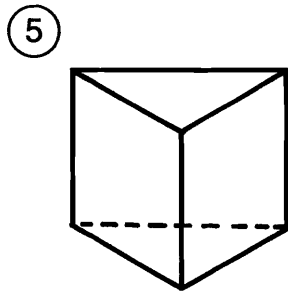
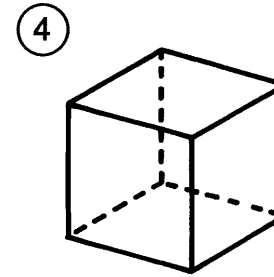
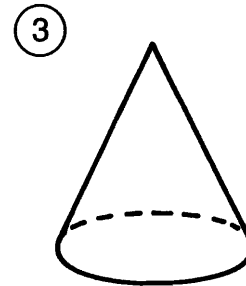
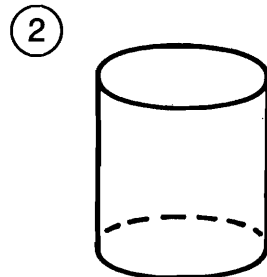
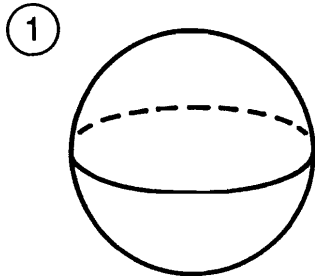

- Ⓤ triangular pyramid
- Ⓣ hexagonal prism
- Ⓡ cone
- Ⓣ triangular prism
- ⓔ sphere
- Ⓜ rectangular prism
- Ⓞ pentagonal prism
- Ⓞ cube
- Ⓤ pentagonal pyramid
- ⓐ cylinder
- ⓔ hexagonal pyramid
- Ⓨ rectangular pyramid

Why Did the River Guide Carry a Rifle?

Find the PERIMETER of each figure. Cross out the box containing each correct answer. When you finish, write the letters from the remaining boxes in the spaces at the bottom of the page.

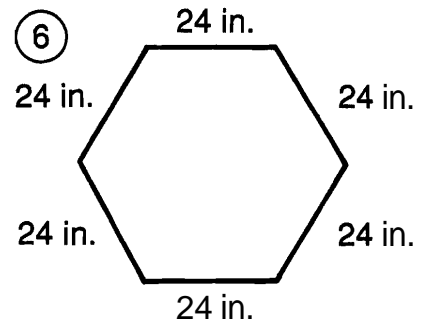
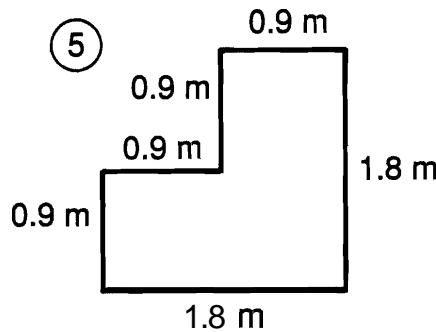
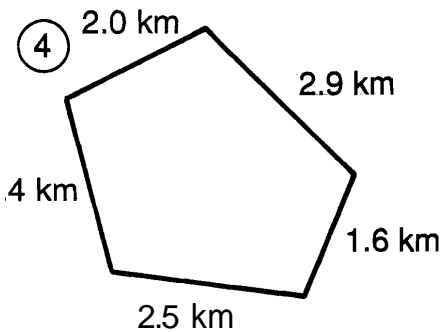
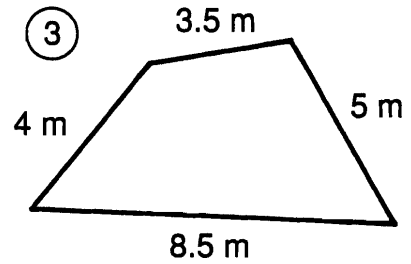
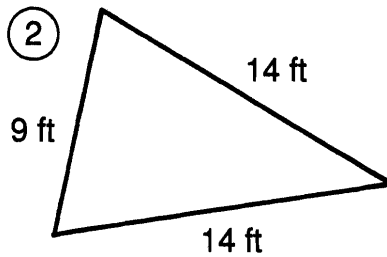
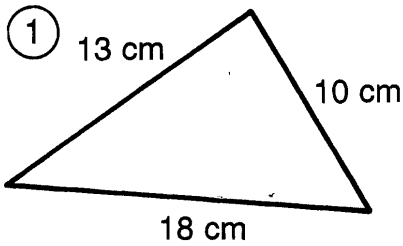

Find the perimeter of each rectangle.

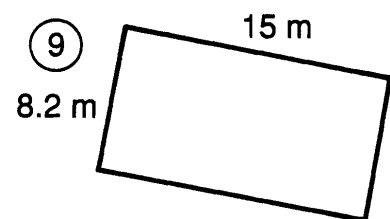
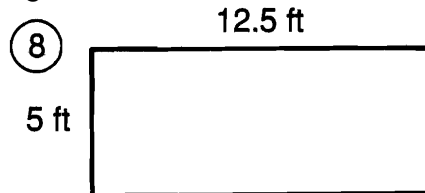
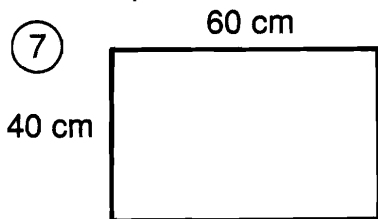

⑩ $l = 48$ mm
 $w = 32$ mm

⑪ $l = 6.2$ km
 $w = 4.7$ km

⑫ $l = 12$ in.
 $w = 12$ in.

⑬ Find the perimeter of a sheet of typing paper $8\frac{1}{2}$ in. wide and 11 in. long.

⑭ How many feet of border are needed to go around a square bulletin board that is 4.5 ft on each side?

HE 48 in.	TO 43.4 m	ST 144 in.	SH 18.6 km	OT 18 ft	OP 21 m	FL 46.4 m	OO 156 in.	LS 37 ft	OA 160 mm	TT 32 ft
HE 180 cm	AT 35 ft	RA 184 mm	IN 21.8 km	TO 7.2 m	SO 41 cm	PI 42 in.	PE 200 cm	NG 39 in.	DS 156 in.	ET 11.4 km

What Is the Title?

TO FIND THE TITLE OF THIS PICTURE:

Do each exercise below and find your answer in the code. Each time the answer appears, write the letter of the exercise above it.

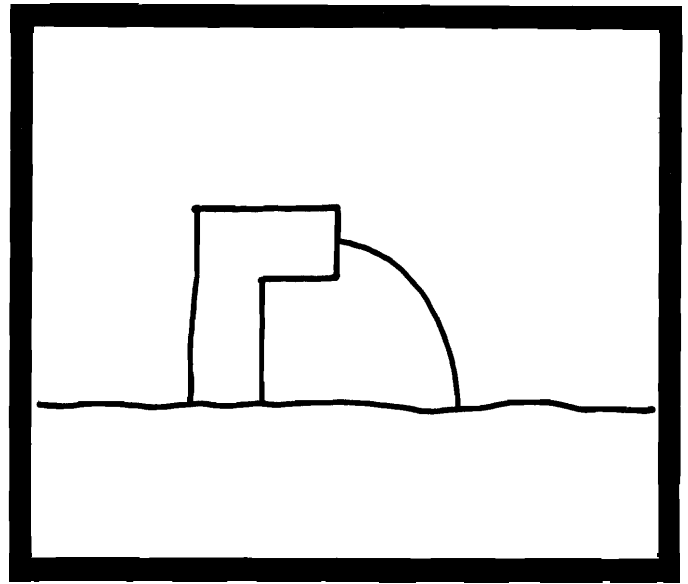

CODED TITLE:

21 6.3 15.75 42 16.6 70 215 15 15.75 21 16.5 15.75 96 65.6 19

15 70 16.6 90 17.25 6.3 64 21 200 100 90 6.3 70 15.75 96 230

I. Find the perimeter of each figure.

- | | |
|--|---|
| (O) Triangle with sides of 8.2 cm, 3.9 cm, and 4.5 cm _____ cm | (B) Rectangle with sides of 22 in. and 28 in. _____ in. |
| (G) Square with sides of 16.4 m _____ m | (I) Equilateral triangle with sides of 5.25 ft _____ ft |
| (E) Parallelogram with sides of 40 cm and 75 cm _____ cm | (H) Regular hexagon with sides of 2.75 in. _____ in. |
| (A) Regular decagon with sides of 0.63 km _____ km | (U) Rhombus with sides of 50 ft _____ ft |

II. Solve.

- | | |
|--|--|
| (L) The width of a large American flag is 8 ft. Its length is 5 ft more than its width. Find its perimeter. _____ ft | (N) The width of a rectangular poster is 16 in. Its length is twice its width. Find its perimeter. _____ in. |
| (M) The perimeter of a square window is 360 cm. Find the length of one side. _____ cm | (F) The perimeter of a triangle is 38 ft. One side is 14 ft long. Another side is 9 ft long. How long is the third side? _____ ft |
| (R) A pennant is shaped like an isosceles triangle. The short side is 14 in. long and is half the length of each longer side. Find the perimeter of the pennant. _____ in. | (S) The longest side of a triangular sail is 9 m long. The second side is 1.5 m shorter than the longest side. The third side is half the length of the longest side. What is the perimeter? _____ m |

Why Did the Piano Player Bang Her Head Against the Keyboard?

Find the circumference (C) of each circle, given the diameter (d) or radius (r). Use 3.14 for π . Draw a straight line connecting the square by the exercise to the square by its answer. The line will cross a number and a letter. Write the letter in the matching numbered box at the bottom of the page.

① $d = 3$ cm ◆		◆ $C = 125.6$ in.
② $d = 8$ in. ◆	⑨	✚ $C = 31.4$ cm
③ $d = 7$ cm ◆	⑬	◆ $C = 94.2$ in.
④ $d = 40$ in. ◆	⑬	◆ $C = 9.42$ cm
⑤ $d = 9.2$ cm ◆	⑥	◆ $C = 72.22$ in.
⑥ $d = 1.5$ in. ◆	②	✚ $C = 301.44$ in.
⑦ $d = 600$ m ◆	⑤	◆ $C = 25.12$ in.
⑧ $d = 23$ in. ◆	⑦	◆ $C = 15.7$ in.
⑨ $d = 10$ cm ◆	⑪	◆ $C = 28.888$ cm
⑩ $r = 1$ in. ◆	⑫	◆ $C = 13.816$ cm
⑪ $r = 6$ cm ◆	⑫	✚ $C = 15.7$ cm
⑫ $r = 15$ in. ◆	⑫	◆ $C = 21.98$ cm
⑬ $r = 2.2$ cm ◆	⑫	◆ $C = 6.28$ in.
⑭ $r = 48$ in. ◆	⑫	✚ $C = 314$ m
⑮ $r = 3.9$ cm ✚	⑫	✚ $C = 4.71$ in.
⑯ $r = 2.5$ in. ◆	⑫	◆ $C = 37.68$ cm
⑰ $r = 2.5$ cm ◆	⑫	◆ $C = 24.492$ cm
⑱ $r = 50$ m ◆	⑫	◆ $C = 1,884$ m

1	2	3	4	5	6	7	8	9	10	11	12	13	14	15	16	17	18
---	---	---	---	---	---	---	---	---	----	----	----	----	----	----	----	----	----

Answers A – I:

18.84 ft	GUY
71.8 ft	HELPED
1,570 m	BOX
51 ft	HAMBURGER
11.932 cm	A
12.56 cm	THE
44 ft	VEGETABLES
13.188 m	WHO
1,630 m	BIG
282.6 m	SILLY
31.4 cm	OF
62.8 ft	DUMPED
11.542 cm	OFF

Did You Hear About...

A	B	C	D	E	F
G	H	I	J	K	L
M	N	O	P	Q	R
					?

Find each answer in the appropriate answer column and notice the word under it. Write this word in the box containing the letter of the exercise.

I. Find the circumference of each circle. Use 3.14 for π .

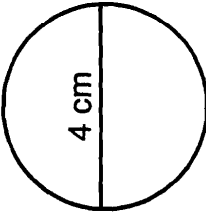
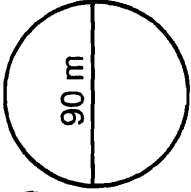
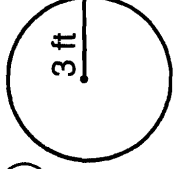
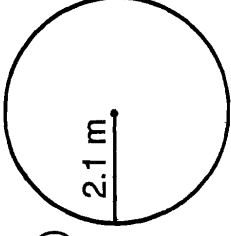
- (A)  (B)  (C)  (D) 
- (E) $d = 20$ ft (F) $d = 3.8$ cm (G) $r = 250$ m (H) $r = 5$ cm

II. Find the circumference of each circle. Use $\frac{22}{7}$ for π .

- (I) $d = 14$ ft (J) $d = 28$ in. (K) $d = 49$ mm (L) $d = 10\frac{1}{2}$ ft
- (M) $r = 21$ mm (N) $r = 3\frac{1}{2}$ in. (O) $r = 105$ mm (P) $r = \frac{3}{4}$ in.

III. Solve. Use 3.14 for π .

- (Q) The wheels on a bicycle have a diameter of 27 in. How far does the bicycle travel with each turn of the wheels?
- (R) The minute hand of a large clock is 6 ft long. How far does the point of the hand move in one hour?

Answers J – R:

$5\frac{2}{7}$ in.	FRESH
22 in.	HE
37.68 ft	EARTH
88 in.	ON
34.5 ft	SUBMARINE
660 mm	WANTED
132 mm	BECAUSE
84.78 in.	ON
154 mm	THE
720 mm	JUMPED
$4\frac{5}{7}$ in.	PEAS
143 mm	TOP
33 ft	GROUND

What Does a Tuba Call Its Father?

Give the number of square units in each figure. Find your answer and cross out the letters above it. When you finish, the answer to the title question will remain.

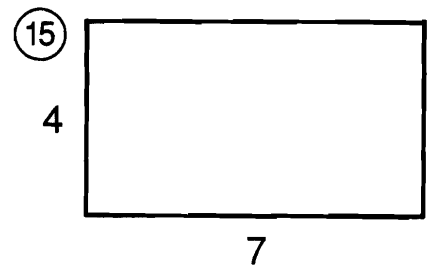
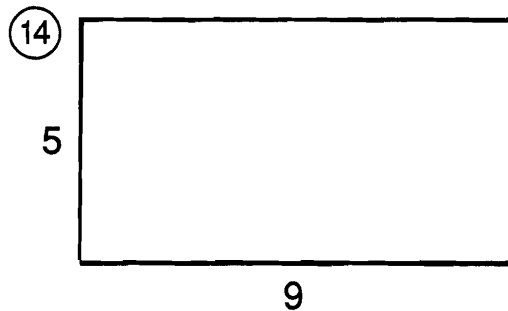
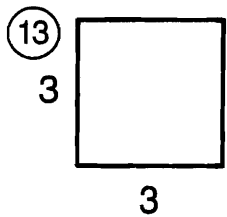
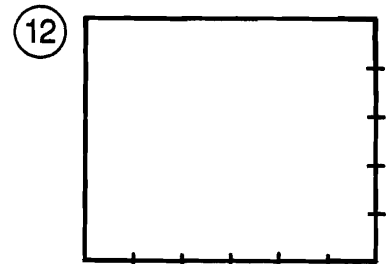
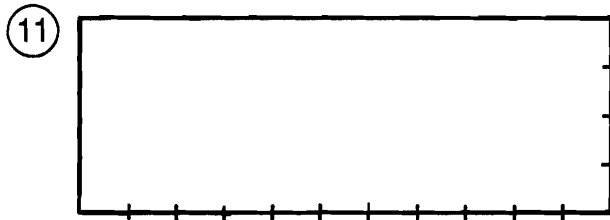
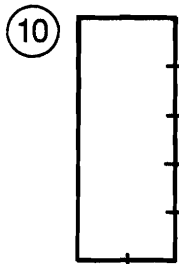
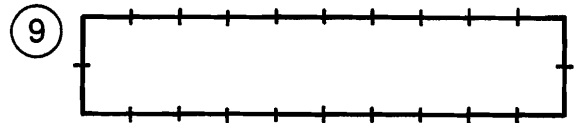
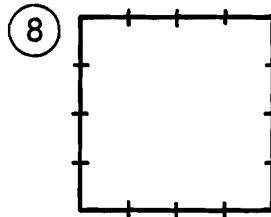
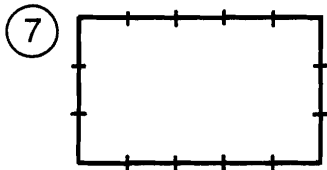
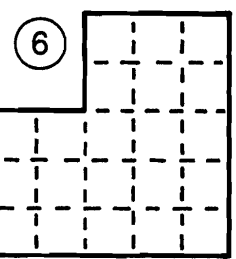
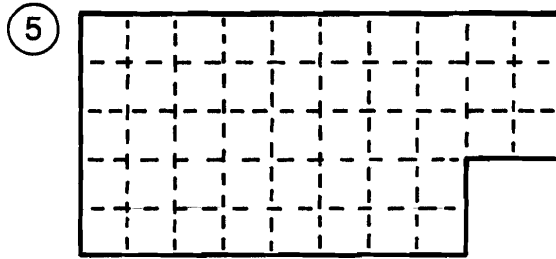
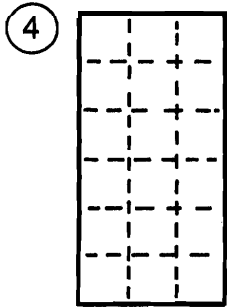
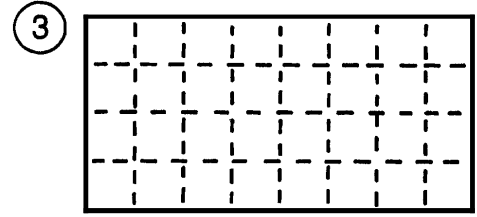
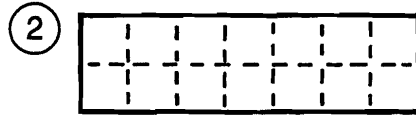
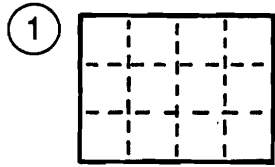

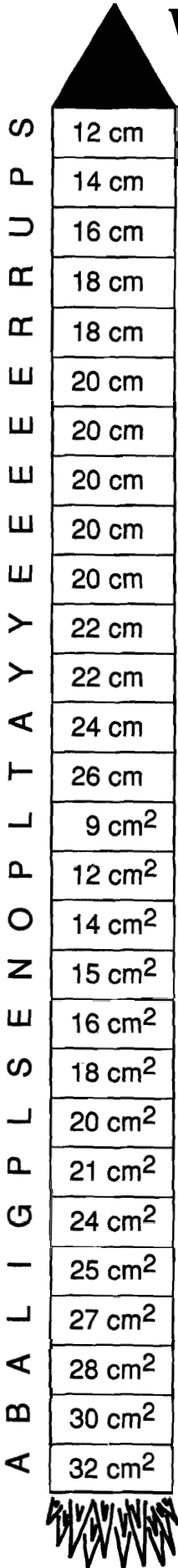

TH	TU	GR	OO	BA	MI	BO	OM	MY	US	PA	IR	ST	OP	UB	PA	LS	AD	AD
32	15	9	42	20	12	28	21	44	18	8	45	24	14	16	27	30	46	10

What Did the Baseball Coach Look For in Space?



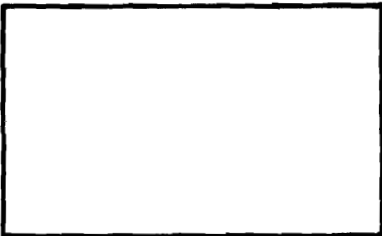

Measure the length and width of each rectangle to the nearest cm. Then compute both the PERIMETER and AREA. Find both answers in the rocket and cross out the letter next to each. (For answers that appear more than once in the rocket, it doesn't matter which one you cross out.)

When you finish, the answer to the title question will remain.

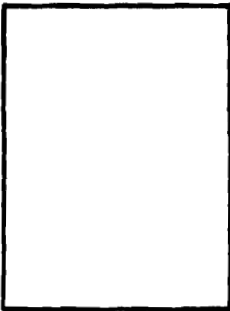
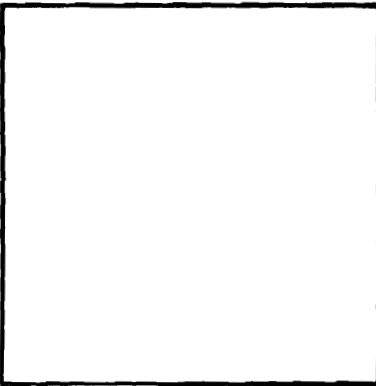
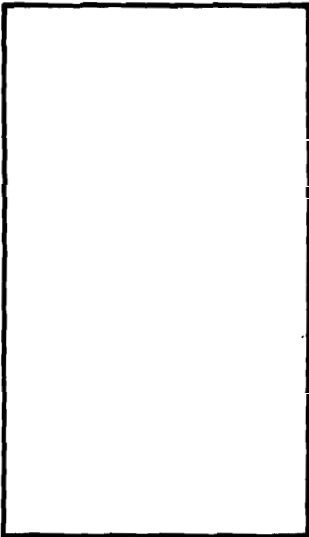
1.  2. 

3.  4.  5. 

6. 

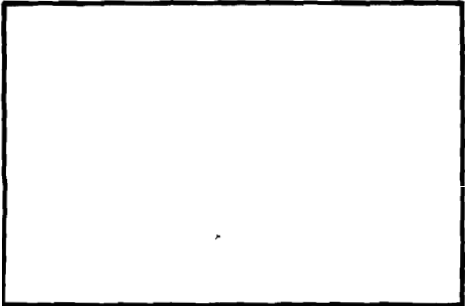
7.  8. 

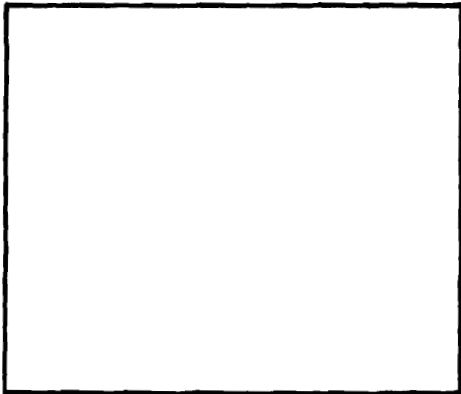
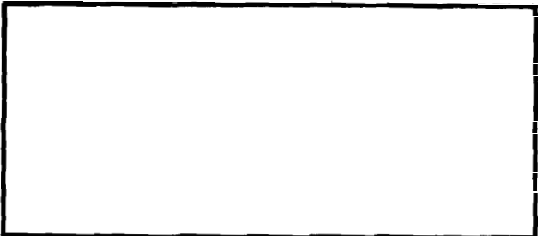
9.  10. 

Why Do Elephants Have Ivory Tusks?

Do each exercise and find your answer in the answer columns. Write the letter of the answer in each box containing the number of the exercise.

I. Find the area of each figure.

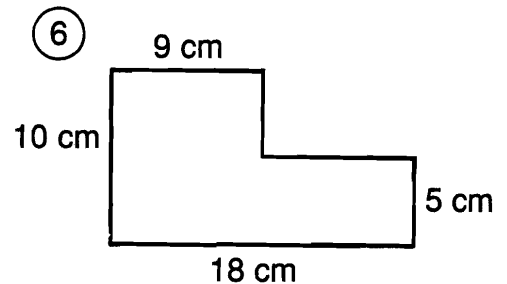
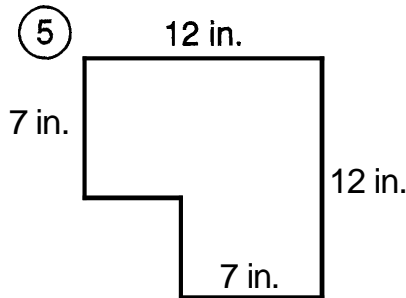
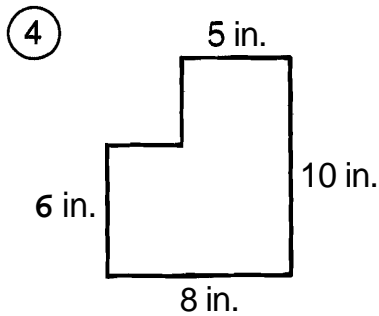
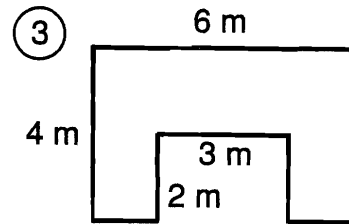
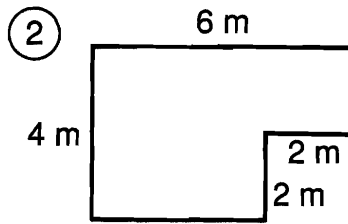
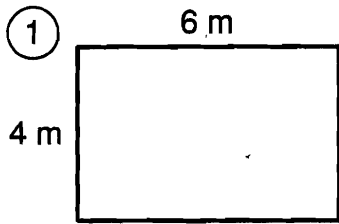

II. Find the area of the shaded region in each figure.

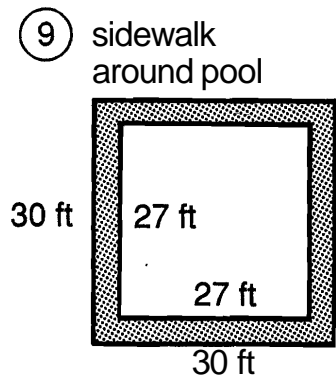
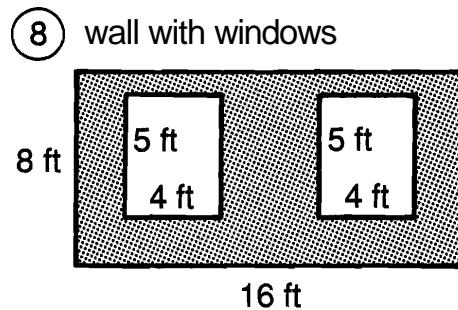
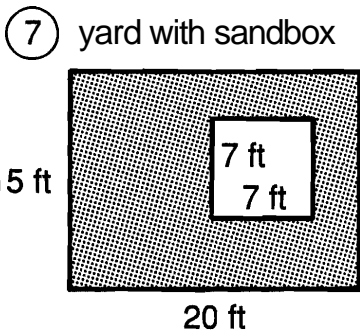

III. Solve.

⑩ A bedroom is 15 ft long and 12 ft wide. How much will it cost to carpet the room if carpeting costs \$22 per square yard? (1 yd = 3 ft)

⑪ A rose garden in the city park is rectangular and is 9 m wide. If the area of the rectangle is 144 m^2 , what is the length of the garden?

ANSWERS

- (A) 219 ft^2 (T) 68 in.^2 (U) 251 ft^2 (G) 124 cm^2 (C) 21 m^2 (N) \$440
 (L) 20 m^2 (F) \$520 (V) 108 in.^2 (E) 24 m^2 (D) 88 ft^2 (P) 19 m
 (I) 135 cm^2 (S) 171 ft^2 (R) 16 m (B) 165 ft^2 (W) 119 in.^2 (O) 18 m^2

6	11	3	10	3	10	1	9	5	3	7	2	8	11	7	9	4
---	----	---	----	---	----	---	---	---	---	---	---	---	----	---	---	---

How Was the Wooden Marionette Related to the Wooden Diving Board?

Use a calculator to solve each problem (round decimal answers to the nearest tenth). Find your answer in the answer column and notice the two letters next to it. Write these letters in the spaces over the exercise number at the bottom of the page.

WORLD RECORD: The largest jigsaw puzzle ever made was 85 by 55 ft and had 15,520 pieces. It was constructed by the United Way in Keene, New Hampshire.

1. What was the area of the puzzle in ft²? _____ ft²
2. What was the area of the puzzle in in.²? _____ in.²
3. What was the average size of each piece? _____ in.²

WORLD RECORD: The world's largest quilt, designed by A. Platteau, measures 69.6 by 99.5 ft. It was made from 16,140 equal-sized squares sewn together.

4. What is the area of the quilt in ft²? _____ ft²
5. What is the area of the quilt in in.²? _____ in.²
6. What is the area of each square? _____ in.²

WORLD RECORD: The world's longest buffet table was 3,304.8 ft long and 8.2 ft wide. On June 19, 1982, approximately 4,000 people, including HM The King of Sweden, were seated at the table.

7. What was the area of the table? _____ ft²
8. What was the perimeter of the table? _____ ft
9. If 4,000 people were equally spaced around the perimeter of the table, how far apart were they sitting? _____ ft

WORLD RECORD: The largest American flag ever made was first displayed on March 22, 1980, and measures 411 by 210 ft.

10. What is the area of the flag in ft²? _____ ft²
11. What is the area of the flag in yd²? _____ yd²
12. The fabric used for the flag weighs about 1.6 lb per yd². About how much does the flag weigh? _____ lb

Answers

- (HA) 1.7
- (HE) 997,228.8
- (OM) 46.5
- (DE) 7,130
- (LY) 673,200
- (TR) 15,344
- (EY) 27,099.4
- (WO) 2.1
- (DT) 4,675
- (SA) 86,310
- (RI) 917,106.8
- (ME) 6,925.2
- (FA) 6,626
- (ST) 14,904
- (EE) 61.8
- (VO) 4,835
- (MI) 9,590
- (TH) 43.4
- (EN) 83,820
- (ER) 28,186.4

3	7	9	1	5	10	4	8	11	2	12	6										

What Happened to Mr. Meter When Mrs. Meter's Mother Flew in for a Visit?

Cross out the box containing each correct answer. When you finish, write the letters from the remaining boxes in the spaces at the bottom of the page.

I. Find the PERIMETER and the AREA of each parallelogram.

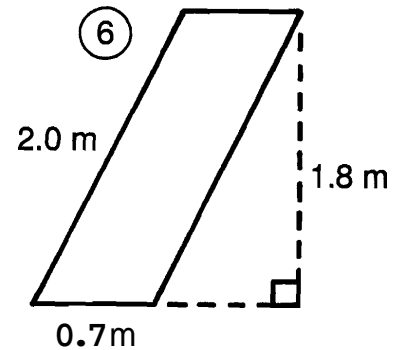
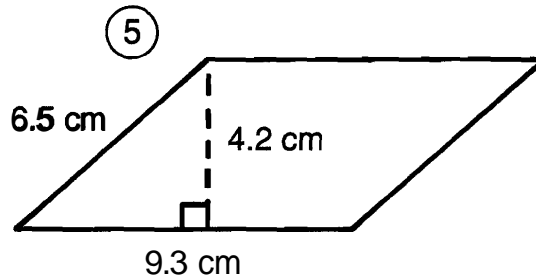
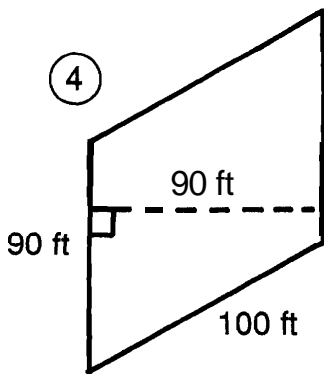
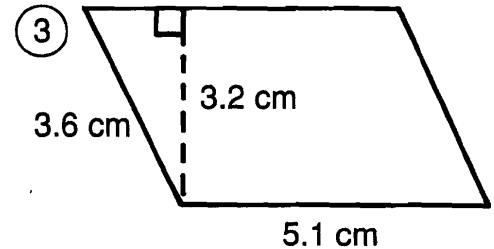
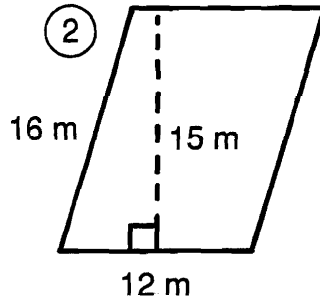
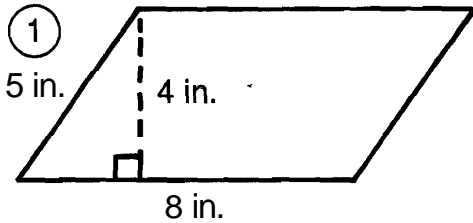

II. Solve.

- ⑦ The base of a parallelogram is 10 in. The height is 2 in. more than half the base. Find the area.
- ⑧ The height of a parallelogram is 4.5 cm. The base is twice the height. What is the area?
- ⑨ The area of a parallelogram is 60 ft^2 . The height is 5 ft. How long is the base?
- ⑩ The area of a parallelogram is 375 cm^2 . The base is 25 cm. Find the height.

T	SH	HE	RE	E	WE	WA	IT
31.6 cm	17.4 cm	33.8 cm	15 cm	32 in.^2	56 m	1.38 m^2	70 in.^2
SC	A	NT	EN	DA	RE	AL	T
37.6 cm^2	180 m^2	12 ft	18 m	380 ft	1.26 m^2	16.32 cm^2	16 ft
PR	IM	V	ET	TY	IS	ER	IT
5.4 m	350 ft	39.06 cm^2	84 in.^2	40.5 cm^2	26 in.	6.3 m	$8,100 \text{ ft}^2$
<div style="display: flex; justify-content: space-between; width: 100%;"> </div>							

Tom Swift Said It This Way, Supposedly

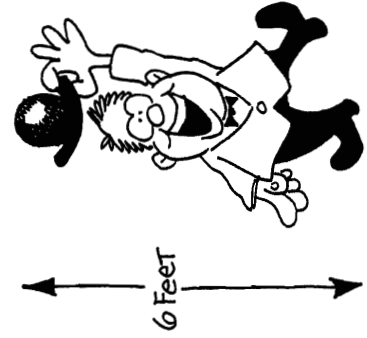

2	10	8	12	12	13	4		
13	8	14	6	1	14	6	13	4
5	11	3	13	9	1	14	5	7

1. "I hate playing tic-tac-toe," Tom said
2. "I wish I were six feet tall," Tom said
3. "I just flew in from the coast," Tom

Find the area of each triangle, then find your answer in the answer column. Write the letter of the answer in each box containing the number of the exercise.

①

②

③

④

⑤

⑥

⑦

⑧

⑨

⑩

⑪

⑫

- ⑬ A triangular sail has a base of 5 m and a height of 10 m. If canvas costs \$18 a square meter, find the cost of canvas to make the sail.
- ⑭ A square dinner napkin 8 in. on each side is folded along its diagonal. Find the area of the folded napkin.

- Answers**
- (R) 100.1 cm²
 - (T) 24 in.²
 - (G) 10.5 ft²
 - (S) 810 ft²
 - (U) 96.5 cm²
 - (I) 20 in.²
 - (A) 187.5 m²
 - (P) 70 cm²
 - (B) \$475
 - (D) 22.5 cm²
 - (N) 32 in.²
 - (C) 72 m²
 - (F) 790 ft²
 - (E) 68 cm²
 - (X) 3.15 km²
 - (H) 172.5 m²
 - (O) 7.5 in.²
 - (L) \$450
 - (Y) 144 mm²
 - (K) 8.25 in.²
 - (M) 3.4 km²

What Happens When the Smog Lifts in Los Angeles, California?

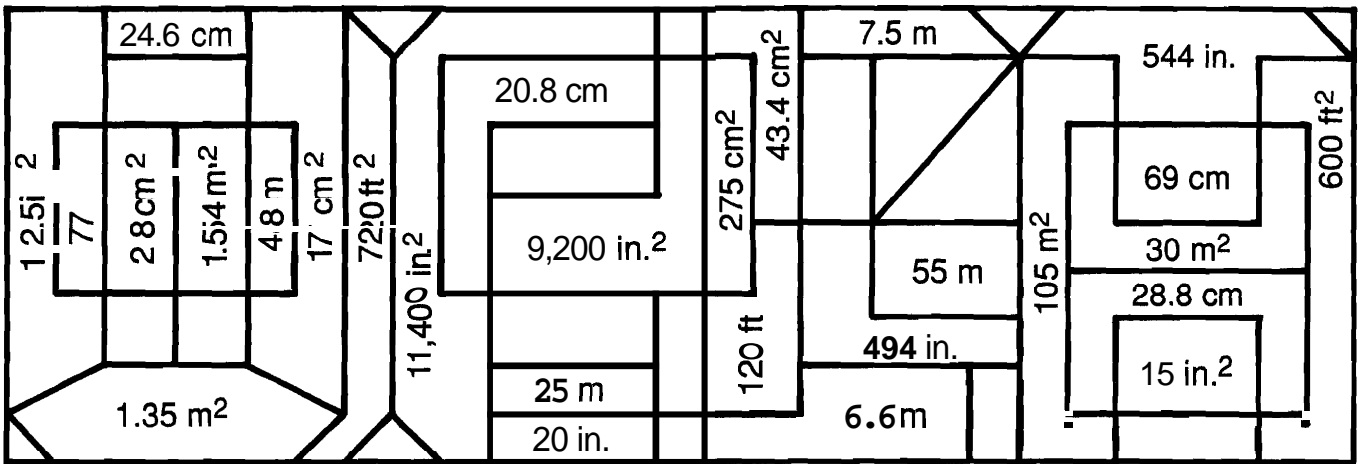

Find the AREA and the PERIMETER of each triangle below. Look for both answers in the rectangle. Shade in each area containing a correct answer.

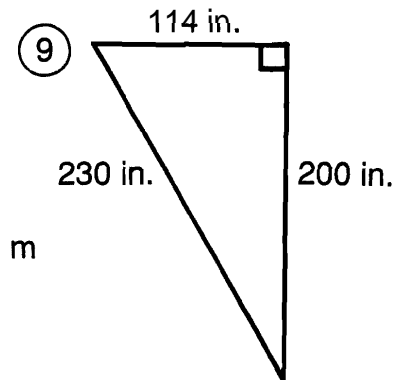
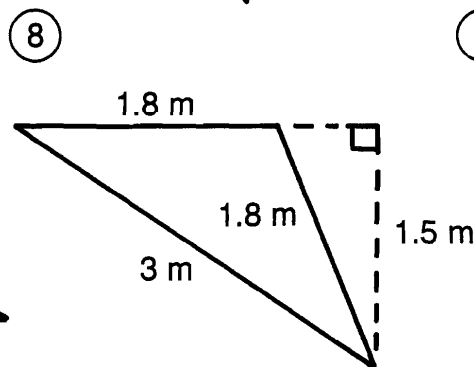
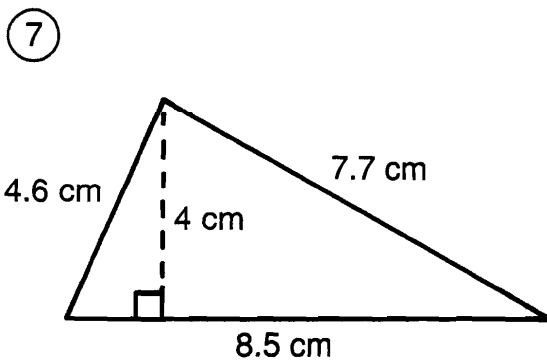
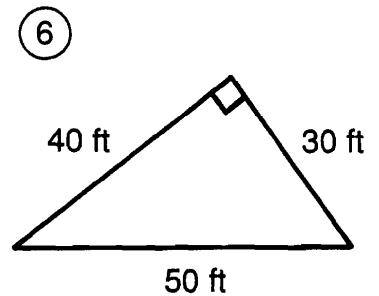
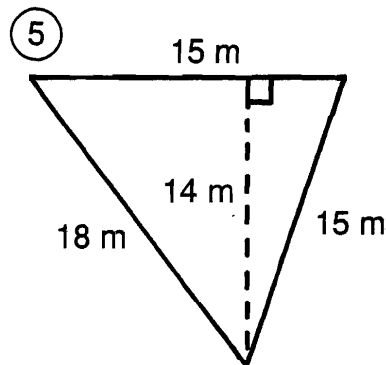
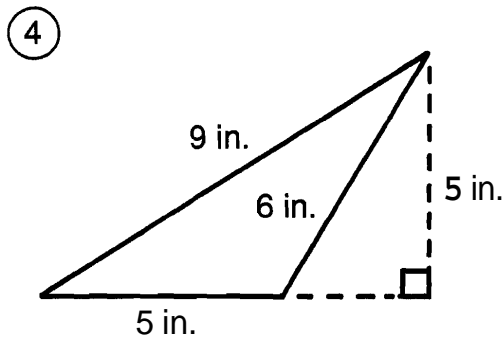
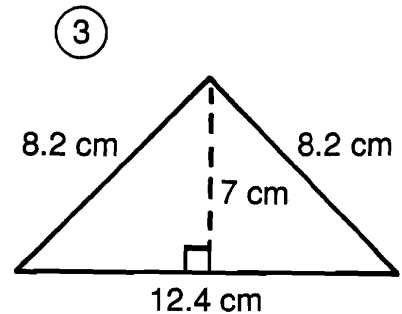
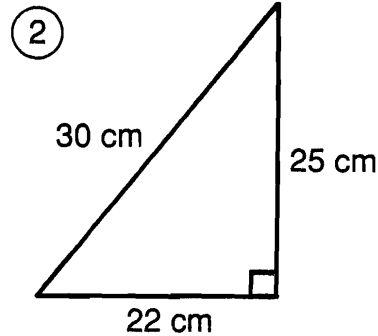
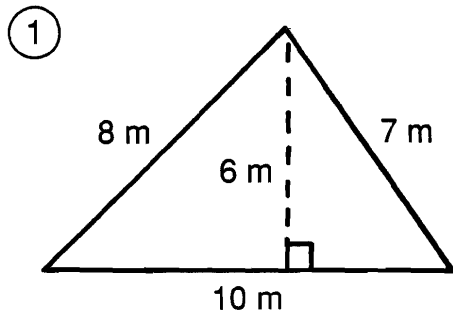

Why Was Igor Unhappy About His Spelling Test Even Though He Got Everything Right?

Give both the perimeter and area of each figure. Find each answer in the appropriate answer column. Fill in the correct unit of measure for each answer you choose, then circle the number-letter next to it. Write the letter in the matching numbered box at the bottom of the page.

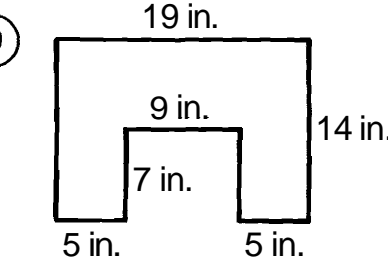
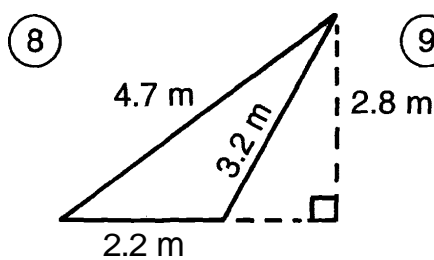
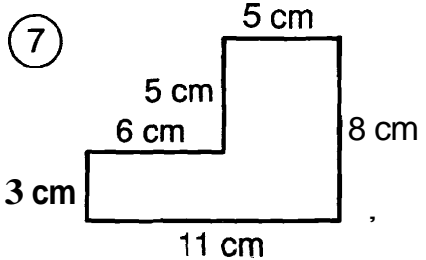
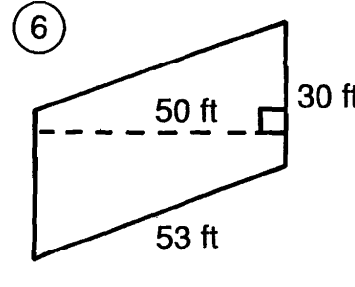
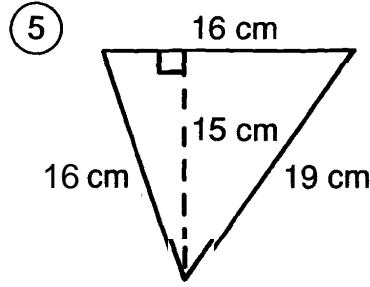
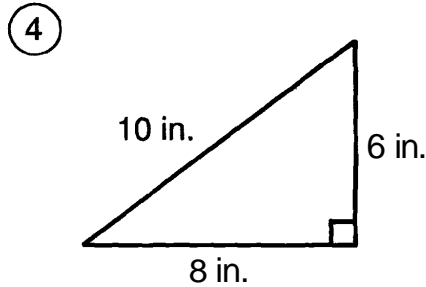
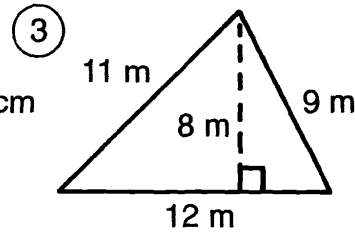
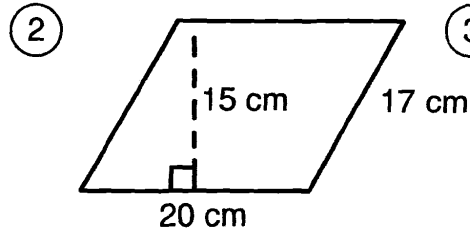
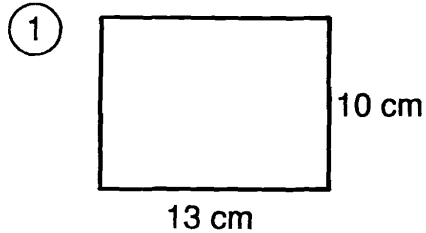

⑩ Rectangle with sides of 22 cm and 28 cm.

⑪ Square with sides measuring 12 in.

⑫ Right triangle with sides of 8 m, 15 m and 17 m.

Perimeters		Areas	
95	21-S	58	13-L
24	17-E	34	24-A
67	18-S	300	6-S
10.1	8-E	60	21-H
46	12-L	136	4-R
152	16-R	3.08	29-S
100	25-W	64	11-O
38	20-T	24	26-O
32	1-H	144	27-R
40	4-M	3.26	19-I
9.4	27-L	130	28-D
51	5-I	1,500	2-E
74	22-E	203	11-A
34	25-F	48	9-D
48	7-S	240	13-P
166	15-T	616	19-O
49	8-A	120	23-R
80	16-H	576	7-H

1	2	3	4	5	6	7	8	9	10	11	12	13	14	15	16	17	18	19	20	21	22	23	24	25	26	27	28	29
---	---	---	---	---	---	---	---	---	----	----	----	----	----	----	----	----	----	----	----	----	----	----	----	----	----	----	----	----

What Game Did Tarzan Like to Play?

Do each exercise below. Find your answer in the answer columns and notice the letter next to it. Look for this letter in the string of letters near the bottom of the page and CROSS IT OUT each time it appears. When you finish, write the remaining letters in the rectangle at the bottom of the page.

I. Find the area of each trapezoid.

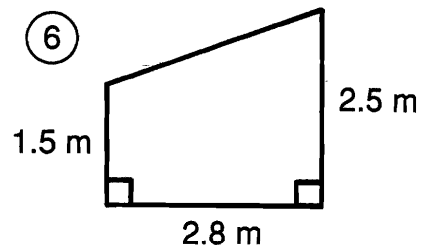
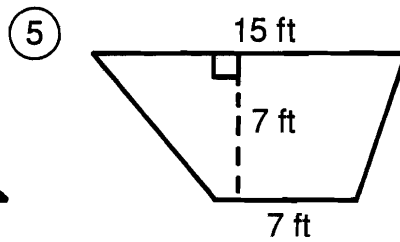
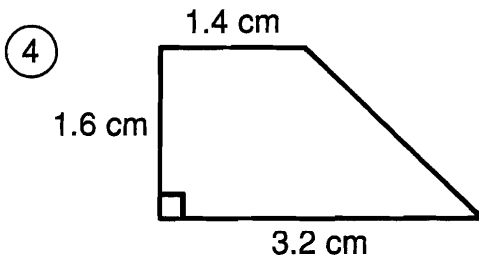
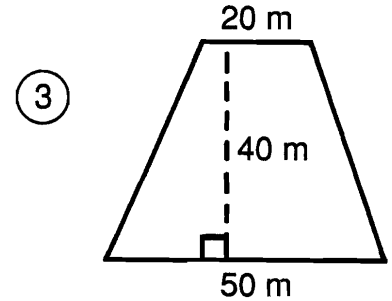
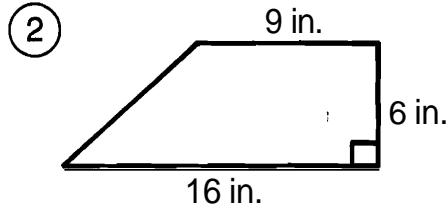
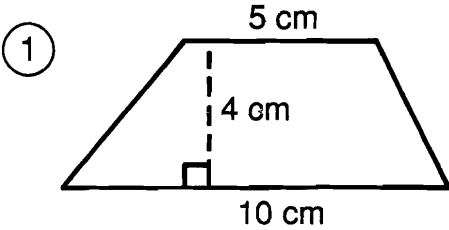

⑦ $b_1 = 11 \text{ in.}$
 $b_2 = 9 \text{ in.}$
 $h = 8 \text{ in.}$

⑧ $b_1 = 3.4 \text{ m}$
 $b_2 = 6.4 \text{ m}$
 $h = 5.0 \text{ m}$

⑨ $b_1 = 70 \text{ cm}$
 $b_2 = 30 \text{ cm}$
 $h = 25 \text{ cm}$

II. An artist designed a base for one of his sculptures with the dimensions shown. The top and bottom are rectangles. The sides are isosceles trapezoids.

- ⑩ Find the area of the front face (20 cm base).
 ⑪ Find the area of the side face (12 cm base).
 ⑫ Find the area of the top.

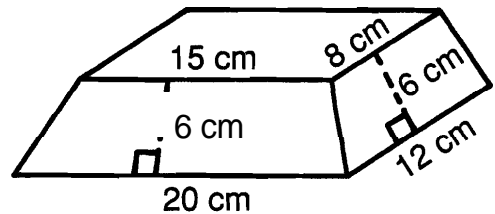

Y 76 in. ²	N 105 cm ²	O 80 in. ²	D 3.68 cm ²	S 3.92 cm ²
L 24.5 m ²	B 30 cm ²	T 120 cm ²	Z 1,360 cm ²	F 5.6 m ²
A 72 cm ²	R 69 ft ²	P 26.2 m ²	M 75 in. ²	I 60 cm ²
U 1,400 m ²	C 95 cm ²	G 77 ft ²	H 1,250 cm ²	E 4.5 m ²

D T B C H O R I N F A M T U O Z D N Y F A L T B P I E G U N S H

Answer to puzzle:

What Is Dangerous about Living for 7 Days on Just One Can of Sardines?

- Answers 1 – 9:**
- (P) 214.14 ft²
 - (A) 54.84 in.²
 - (U) 19.625 cm²
 - (B) 361.14 m²
 - (I) 28.26 cm²
 - (G) 7,850 in.²
 - (L) 314 m²
 - (C) 5.1016 km²
 - (F) 254.34 ft²
 - 379.94 m²
 - (O) 50.24 in.²
 - (T) 18.485 cm²
 - (A) 4.5216 km²
 - 12.56 cm²
 - (R) 6,430 in.²

Find the area of each circle. Use 3.14 for π . Find your answer in the appropriate answer column. Write the letter of the answer in the space containing the number of the exercise. If the answer has a ●, shade in the space instead of writing a letter in it.

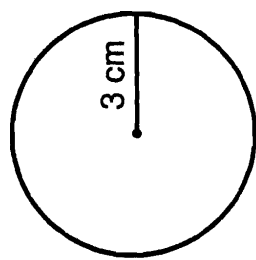
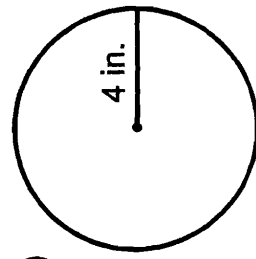
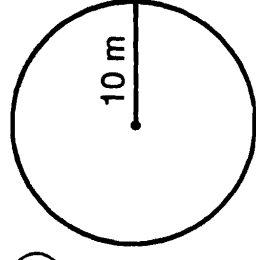
(1)		(2)		(3)	
(4) $r = 2$ cm	(5) $r = 9$ ft	(6) $r = 1.2$ km	(7) $r = 50$ in.	(8) $r = 11$ m	(9) $r = 2.5$ cm

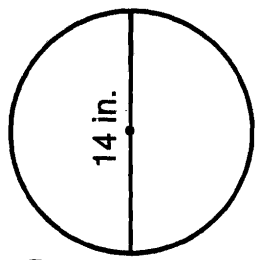
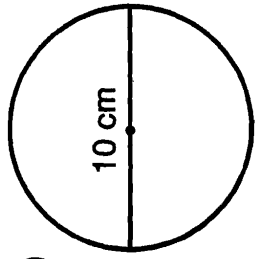
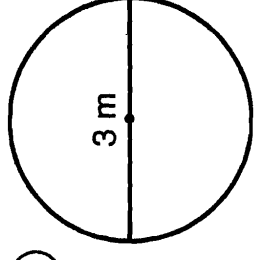
(10)		(11)		(12)	
(13) $d = 16$ ft	(14) $d = 40$ m	(15) $d = 12$ in.	(16) $d = 7$ cm	(17) $d = 0.6$ km	(18) $d = 2$ cm

- Answers 10 – 18:**
- (P) 1,416 m²
 - (O) 78.5 cm²
 - (D) 36.815 cm²
 - 7.065 m²
 - (H) 0.2826 km²
 - (N) 108.74 in.²
 - (M) 1,256 m²
 - (T) 153.86 in.²
 - (S) 211.36 ft²
 - (L) 38.465 cm²
 - (F) 3.14 cm²
 - (Y) 200.96 ft²
 - 0.3416 km²
 - (R) 8.415 m²
 - (F) 113.04 in.²

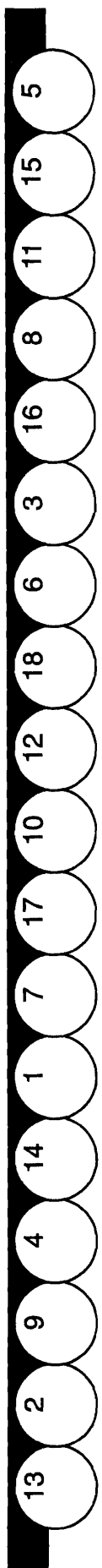

What Is the Title of This Picture?

Use the diameter (d) or radius (r) of each circle to find the circumference (C) and area (A) of the circle. Use 3.14 for π . Round answers to the nearest hundredth (if necessary). Each time an answer appears in the coded title, write the letter of the exercise above it.

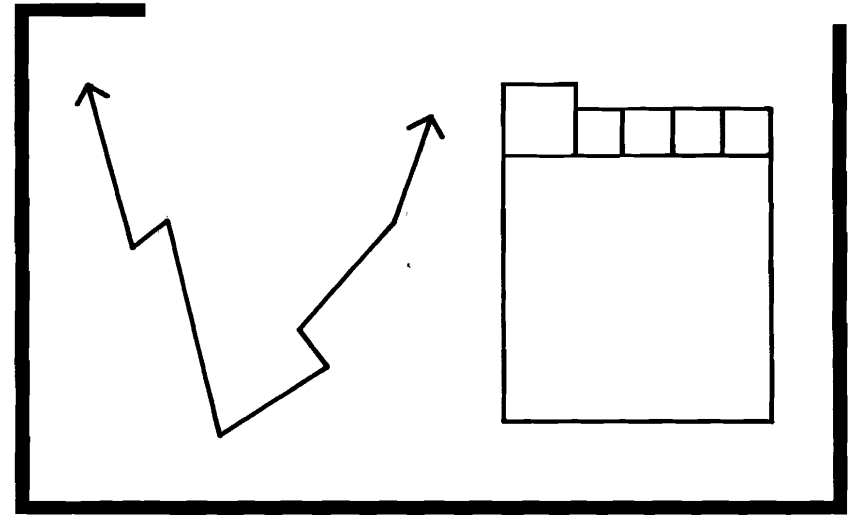

CODED TITLE:

D-60

5,024 176.63 0.7 40 1,017.36 0.7 5.2 4,954 18.84 47.1 3 113.04 0.7 1.69 5,024 28.26 4.40 21.23
16.33 47.1 0.7 172.38 36 1.54 251.2 18.84 176.63 0.7 984.46 15 16.33 16.33 4.40

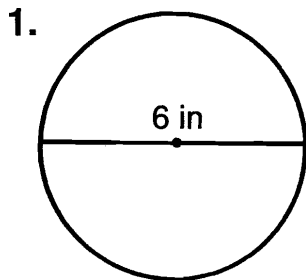

- (G) $r = \underline{\hspace{1cm}}$ in.
- (A) $C = \underline{\hspace{1cm}}$ in.
- (I) $A = \underline{\hspace{1cm}}$ in.²

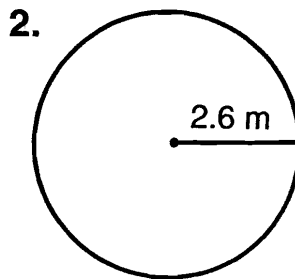

- (D) $d = \underline{\hspace{1cm}}$ m
- (O) $C = \underline{\hspace{1cm}}$ m
- (H) $A = \underline{\hspace{1cm}}$ m²

3. $d = 80$ ft
- (C) $r = \underline{\hspace{1cm}}$ ft
 - (U) $C = \underline{\hspace{1cm}}$ ft
 - (W) $A = \underline{\hspace{1cm}}$ ft²

5. $d = 1.4$ cm
- (E) $r = \underline{\hspace{1cm}}$ cm
 - (T) $C = \underline{\hspace{1cm}}$ cm
 - (Q) $A = \underline{\hspace{1cm}}$ cm²

4. $r = 18$ in.
- (S) $d = \underline{\hspace{1cm}}$ in.
 - (L) $C = \underline{\hspace{1cm}}$ in.
 - (K) $A = \underline{\hspace{1cm}}$ in.²

6. $r = 7.5$ mm
- (F) $d = \underline{\hspace{1cm}}$ mm
 - (N) $C = \underline{\hspace{1cm}}$ mm
 - (R) $A = \underline{\hspace{1cm}}$ mm²

Why Is a Mathematician Like an Airline?

Round each answer to the nearest hundredth (if necessary) and find it in the appropriate **answer** column. Use **3.14** for π . Fill in the correct unit of measure for each answer you choose. Write the letter of the exercise in the box containing the number of the answer.

1. A circle has a radius of **12** in. Find:

- (E) The diameter of the circle.
- (H) The circumference of the circle.
- (T) The area of the circle.

2. A circle has a radius of **4.4** cm. Find:

- (S) The diameter of the circle.
- (Y) The circumference of the circle.
- (H) The area of the circle.

3. A circle has a diameter of **60** m. Find:

- (I) The radius of the circle.
- (O) The circumference of the circle.
- (T) The area of the circle.

4. A circle has a diameter of **1.8** km. Find:

- (O) The radius of the circle.
- (E) The circumference of the circle.
- (U) The area of the circle.

5. Solve.

- (B) Jack's cow is tied to a beanstalk with a piece of **rope** that is **15** ft long. What is the area of the circle in which the cow can graze?
- (T) A round game table has a diameter of **1** m. How much plastic laminate is needed to cover the top of this table?
- (S) The diameter of the earth at the equator is about **8,000** mi. Based on this figure, how far is it around the earth?
- (P) Radio station KROQ broadcasts in all directions to a distance of **40** mi. How many square miles are in the station's broadcast area?
- (L) **WORLD RECORD:** The world's largest Ferris Wheel was built in London in 1897. The wheel had a radius of **150** ft. How far would you travel in one turn of this wheel?

Answers 1 – 3:

- (4) 27.63
- (14) 61.43
- (16) 30
- (2) 75.36
- (12) 461.36
- (21) 8.8
- (17) 172.4
- (13) 24
- (9) 60.79
- (1) 2,826
- (8) 452.16
- (5) 25.51
- (7) 188.4
- (10) 2,516

Answers 4 – 5:

- (15) 898
- (6) 706.5
- (13) 5,174
- (5) 24,930
- (11) 2.54
- (20) 0.79
- (19) 0.9
- (18) 942
- (10) 690.5
- (14) 2.91
- (15) 5,024
- (3) 5.65
- (17) 0.87
- (12) 25,120

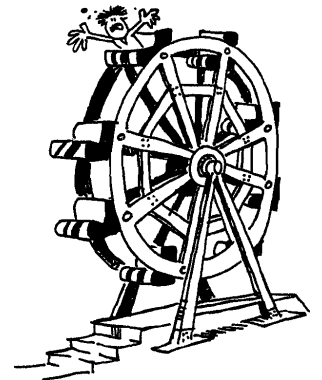

1	2	3	4	5	6	7	8	9	10	11	12	13	14	15	16	17	18	19	20	21
---	---	---	---	---	---	---	---	---	----	----	----	----	----	----	----	----	----	----	----	----

How Do You Get a One-Armed Monkey Down From a Coconut Tree?



Solve each problem. Use 3.14 for π . Find your answer and cross out the letter next to it. When you finish, the answer to the title question will remain.

E	95 in. ²
M	9.2 in.
T	706.5 cm ²
I	8.3 m
E	8.4 in.
R	26 ft
H	1,670 ft ²
T	131 in. ²
O	30 ft
Y	9.6 in.
A	127.2 cm ²
R	2.5 cm
E	28 ft
V	69.5 in. ²
T	21.5 in. ²
I	154 in. ²
A	814.5 cm ²
G	7.8 m
N	593.5 cm ²
I	59 in. ²
W	30.5 in. ²
S	78.5 in. ²
H	1,960 ft ²
T	113.0 cm ²

- Find the diameter of a circle if the circumference is 8 cm. Round to the nearest tenth.
- Find the diameter of a circle if the circumference is 24.5 m. Round to the nearest tenth.
- The largest living thing on earth is a California sequoia tree named the "General Sherman." The circumference of its trunk is about 82 ft. Find the diameter of the trunk to the nearest whole number.
- A revolving water sprinkler sprays water in all directions to a distance of 25 ft. What area does it cover? Round to the nearest 10 ft².
- Pizza Mind Pizza sells a large pizza with a diameter of 14 in. and a medium pizza with a diameter of 11 in. Find the following to the nearest whole number:
 - The area of the large pizza.
 - The area of the medium pizza.
 - How much larger is the large pizza?
- Nick Claus plans to have a model train running in a circle around his holiday tree. How many feet of track will he need if the diameter of the circle is 9.5 ft? Round to the nearest whole number.
- A record has a radius of 15 cm. The label has a radius of 6 cm. Find the following to the nearest tenth:
 - The area of the record (including the label).
 - The area of the label.
 - The area of the record that is not covered by the label.
- The diameter of a basketball hoop is 18 in. The circumference of a basketball is 30 in.
 - Find the diameter of the basketball. Round to the nearest tenth.
 - How much less is the diameter of the basketball than the diameter of the hoop?
- A circle is cut out of a piece of plywood that is 10 in. square. The scraps are thrown away.
 - Find the area of the circle.
 - How many square inches of plywood are thrown away?

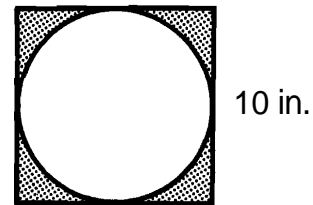
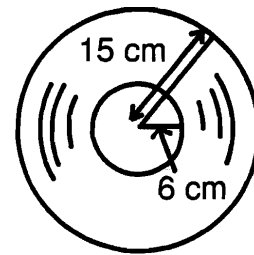

When Is a Chair Like the Fabric Used to Make It?

Write the correct formula to use in solving each problem. Find your answer in the Code Key and notice the letter next to it. Write this letter in the box containing the number of the problem.

4	9	7	5	3	10	1	12	6	2	8	11
---	---	---	---	---	----	---	----	---	---	---	----

- 1 A botanical garden was designed in the shape of a pentagon. How many meters of fencing are needed to go around the garden?

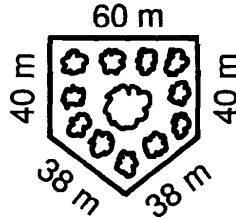

- 2 How many square feet of wallpaper are needed to cover a wall 8 ft high by 15 ft wide?
- 3 The diameter of a circular running track is 140 yd. How far would you run in one lap?
- 4 How much weather stripping is needed to go around a square window measuring 42 in. on a side?
- 5 A dangerous criminal has escaped from prison. The police believe he could not have traveled more than 10 mi in any direction from the prison. How many square miles must be searched?
- 6 How much lace edging is needed to go around a rectangular tablecloth measuring 52 in. by 70 in.?

- 7 How many tiles are needed to cover a square patio measuring 18 ft on a side if each tile covers 1 sq ft?
- 8 The orbit of the earth around the sun is approximately a circle with a radius of 93,000,000 mi. How far do we travel in one orbit around the sun?

- 9 How much felt is needed to make this banner?

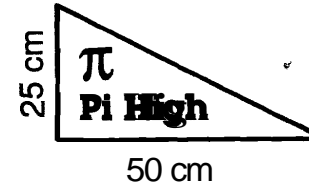

- 10 If each bag of fertilizer covers 2,000 sq ft, how many bags are needed to fertilize a rectangular lawn measuring 100 ft by 160 ft?
- 11 A lighthouse beacon can be seen 24 mi in all directions. What is the area over which the beacon can be seen?
- 12 Popeye put colorful plastic tape around the edge of a triangular sail. The sail had sides of 10 ft, 15 ft, and 18 ft. How many feet of tape did he use?

Code Key

Perimeter Circumference

(S) $P = \text{sum of the lengths of the sides.}$

(A) $P = 2\ell + 2w$

(W) $P = 4s$

(I) $C = \pi d$ or
 $C = 2\pi r$

Area

(T) $A = \ell w$

(E) $A = s^2$

(H) $A = \frac{1}{2}bh$

(N) $A = \pi r^2$

What Happened to Zelda After She Swallowed Two Nickels, Three Dimes, and a Quarter?

Give the SURFACE AREA of each prism. Find your answer in the answer columns and notice the two letters next to it. Write these letters in the spaces over the exercise number at the bottom of the page.

①

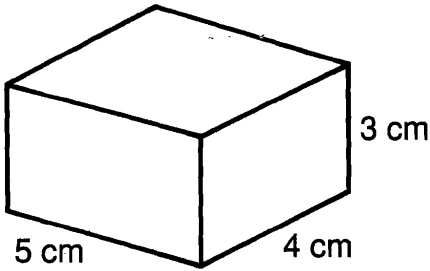

②

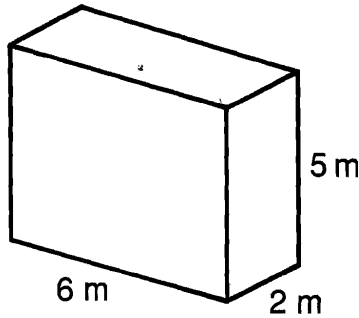

③

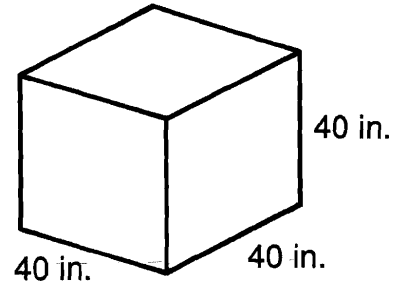

④

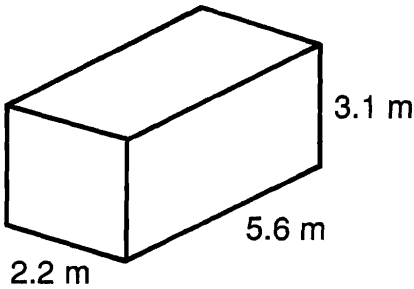

⑤

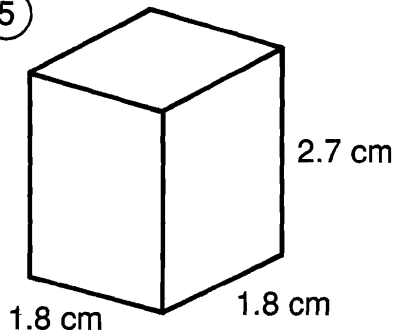

⑥

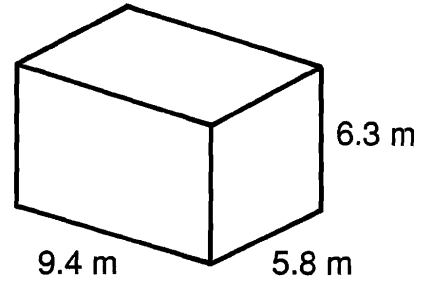

⑦

A rectangular storage box is 12 in. wide, 15 in. long, and 9 in. high. How many square inches of colored paper are needed to cover the surface of the box?

⑧

A teacher made a pair of foam dice to use in math games. Each cube measured 10 in. on a side. How many square inches of fabric were needed to cover the two cubes?

ⓉH 73 m²

Answers

ⓄB 8,560 in.²

ⒶL 23.12 cm²

ⒶS 94 cm²

ⒺR 318.26 m²

ⓃO 25.92 cm²

ⒺW 846 in.²

ⒶT 86 m²

ⒶN 9,600 in.²

ⓅL 1,050 in.²

ⒺR 104 m²

ⒸH 1,200 in.²

ⒺG 300.56 m²

ⓉR 85 cm²

4	2	7	1	5	8	3	6												

What Is Cold And Comes In Cans?

Find the surface area of each figure. Cross out the box containing each correct answer. When you finish, write the letters from the remaining boxes in the spaces at the bottom of the page.

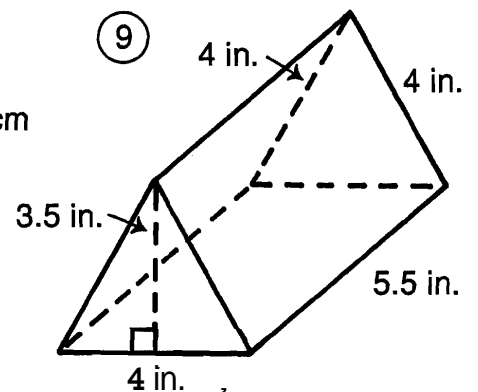
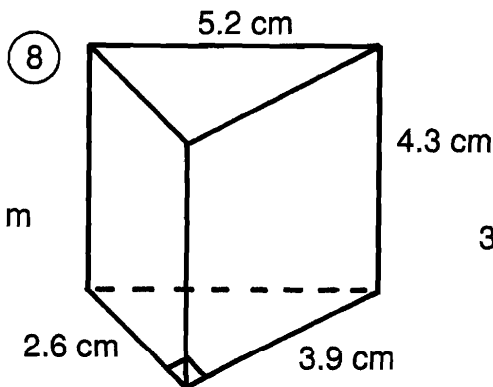
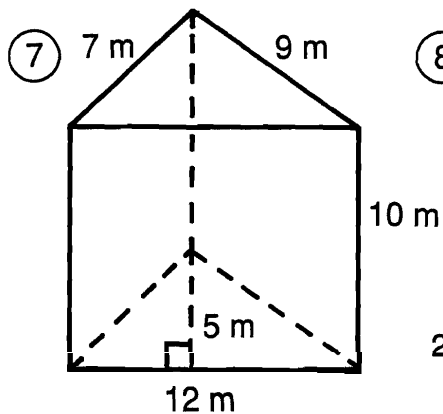
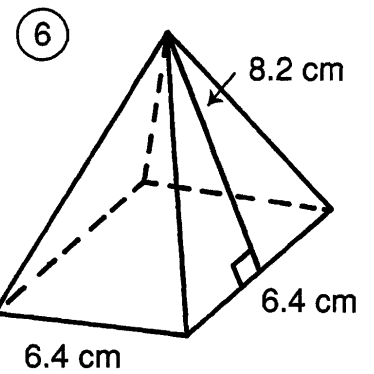
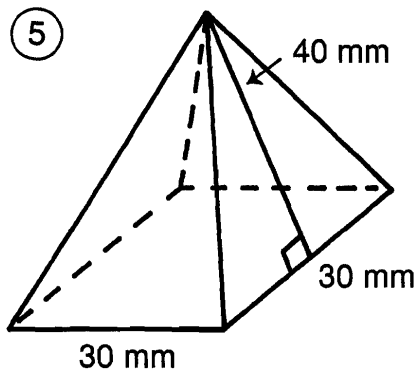
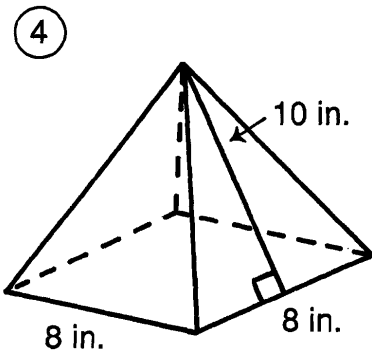
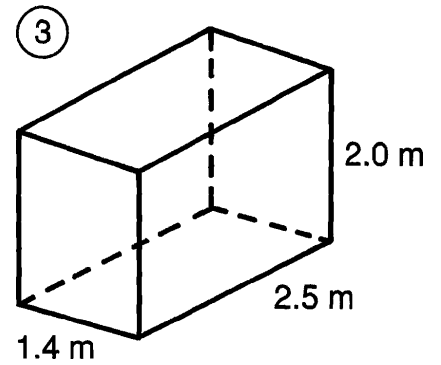
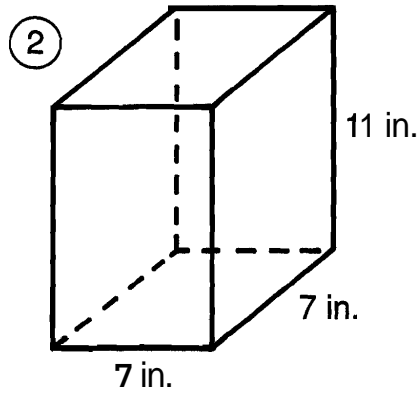
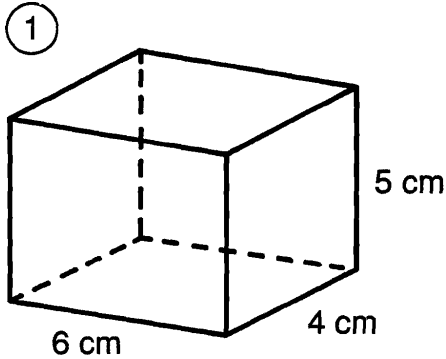

MU	RI	CH	OW	OP	FO	IL
340 m ²	224 in. ²	3,120 mm ²	148 cm ²	80 in. ²	3,300 mm ²	118 in. ²
IB	AR	CL	EA	CA	NS	KE
81.5 cm ²	22.6 m ²	60.45 cm ²	312 m ²	145.92 cm ²	25.8 m ²	406 in. ²

--	--	--	--	--	--	--	--	--	--	--	--

Why Did Humpty Dumpty Have a Great Fall?

Do each exercise and find your answer in the answer column. Write the letter of the answer in each box containing the number of the exercise. Use 3.14 for π .

Find the lateral area and the total surface area of each cylinder.

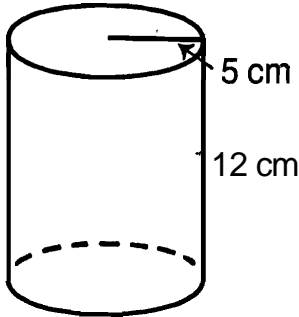

① lateral area: _____

② total area: _____

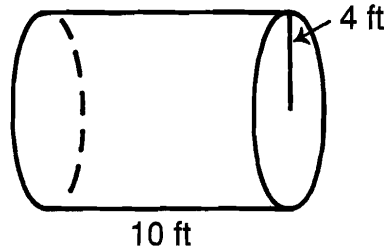

③ lateral area: _____

④ total area: _____

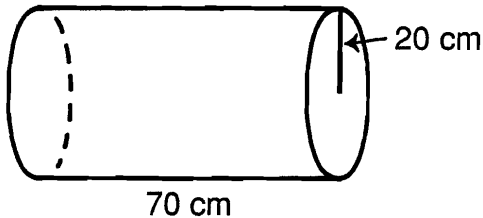

⑤ lateral area: _____

⑥ total area: _____

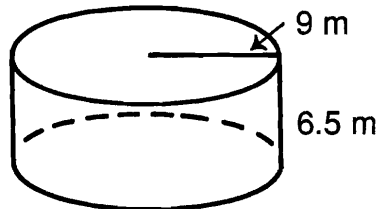

⑦ lateral area: _____

⑧ total area: _____

II. Find the total surface area of each cylinder.

⑨ $r = 3$ cm
 $h = 10$ cm

⑩ $r = 8$ in.
 $h = 8$ in.

⑪ $d = 10.8$ m
 $h = 2.6$ m

III. Solve.

⑫ A can of tomato juice is a cylinder with a radius of 7.5 cm and a height of 20 cm. What is the area of the label around the can?

⑬ A steel oil tank is a cylinder with a diameter of 12 ft and a height of 18 ft. How many square feet of steel were needed to make the tank?

- Ⓐ 271.296 m²
- Ⓑ 942 cm²
- Ⓒ 815.18 ft²
- Ⓓ 376.8 cm²
- Ⓔ 876.06 m²
- Ⓕ 12,412 cm²
- Ⓖ 8,792 cm²
- Ⓘ 311.046 m²
- Ⓚ 11,304 cm²
- Ⓛ 861.6 cm²
- Ⓜ 904.32 ft²
- Ⓝ 412.18 ft²
- Ⓟ 351.68 ft²
- Ⓡ 775.14 in.²
- Ⓢ 367.38 m²
- Ⓣ 251.2 ft²
- Ⓤ 533.8 cm²
- Ⓡ 803.84 in.²
- Ⓚ 792.16 m²
- Ⓛ 412.18 ft²

3	8	13	11	6	4	2	9	5	8	10	11	12	11	1	7	2	13	13	4	10
---	---	----	----	---	---	---	---	---	---	----	----	----	----	---	---	---	----	----	---	----

Mystery: What happened when a 6-year old, a 5-year old, a 4-year old, a 3-year old, and a 2-year old joined to form a basketball team?

Find the volume of each prism in cubic units. Write the letter of the exercise in the box containing the answer.

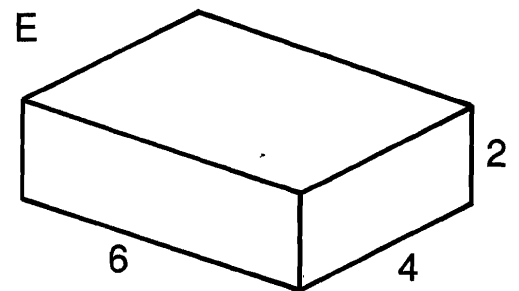
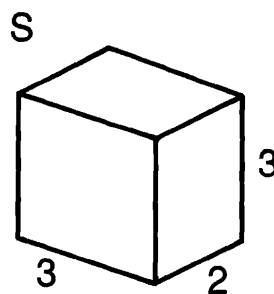
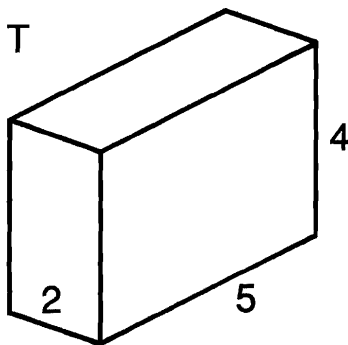
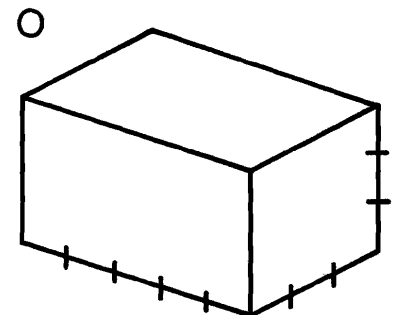
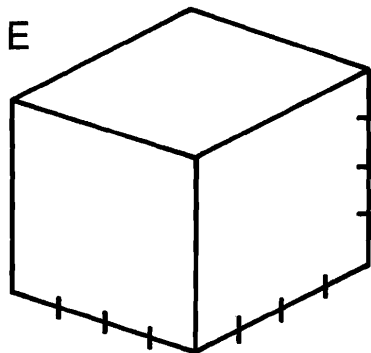
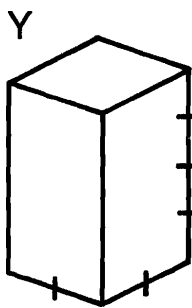
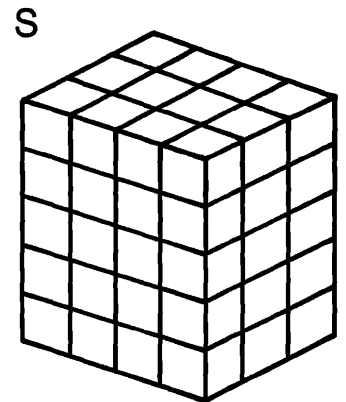
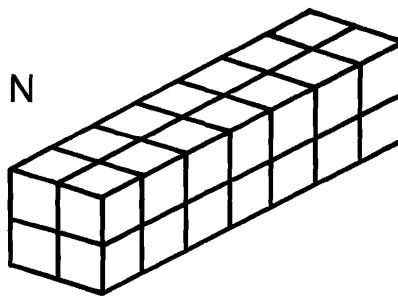
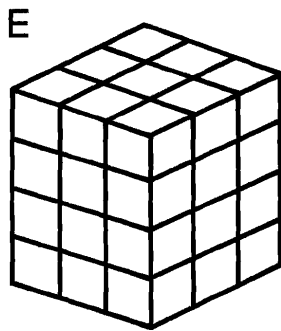
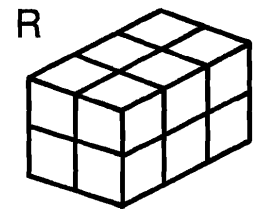
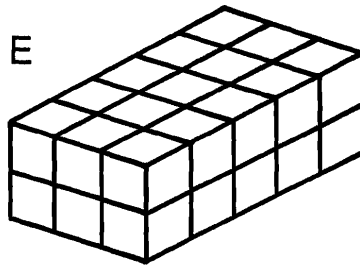
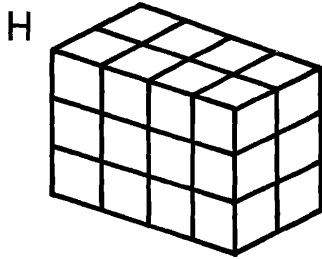

(L) $l = 3; w = 7; h = 2$

(W) $l = 4; w = 3; h = 6$

(E) $l = 5; w = 5; h = 3$

40	24	36	16	32	72	64	12	48	80	45	28	75	42	30	60	18
----	----	----	----	----	----	----	----	----	----	----	----	----	----	----	----	----

What Movie Is about a Kid Who Ran Away from Home with His Bicycle?

Find each answer in the answer columns and notice the two letters next to it. Write these letters in the spaces over the exercise number at the bottom of the page.

I. Find the volume of each rectangular prism.

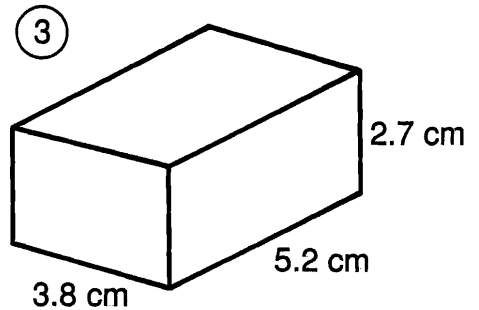
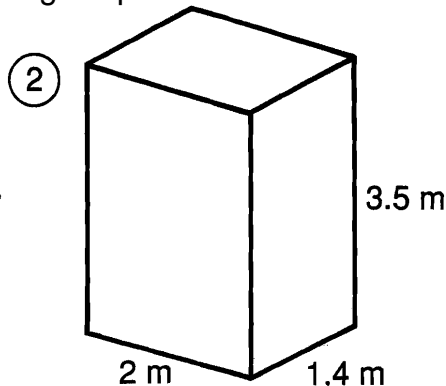
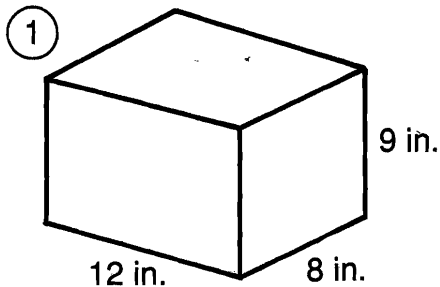

II. Solve.

- ④ A classroom is 26 ft wide, 32 ft long, and 9 ft high. What is the volume of the room in cubic feet?
- ⑤ A swimming pool is 20.6 m long, 8.5 m wide, and has an average water depth of 1.7 m. Find the volume of water needed to fill the pool.
- ⑥ If all the gold that has been produced in the last 500 years could be melted to form a single cube, each side would **measure** about 16 m. How many cubic meters of gold is this?
- ⑦ A refrigerator is 3 ft wide, 2.5 ft deep, and 6 ft high. The walls and other parts of the refrigerator take up 20 ft³. How many cubic feet are left for food?
- ⑧ Krispy Kritters Cereal used to come in a box with a volume of 2,850 cm³. However, The Krispy Kritters Co. designed a new larger box 22.5 cm wide, 6.2 cm deep, and 30 cm high. How many more cubic centimeters will the new box hold than the old box?
- ⑨ An aquarium weighs 22.5 lb when empty. The aquarium is 30 in. long, 14 in. wide, and is filled with water to a depth of 18 in. Water weighs 0.036 pound per cubic inch. How much does the aquarium weigh when it is full of water?

ANSWERS

- (RU) 985 cm³ (ST) 6,118 ft³ (WI) 4,096 m³ (LA) 314.56 lb (TH) 864 in.³
 (NN) 297.67 m³ (CH) 53.352 cm³ (IN) 23.5 ft³ (GO) 1,335 cm³ (LE) 311.27 m³
 (WI) 294.66 lb (ES) 25 ft³ (NE) 9.8 m³ (PA) 3,986 m³ (TH) 7,488 ft³

8	2	6	1	4	7	3	9	5											

What Is Big, Gray, and Lives in California?

Find the volume of each prism. Write the letter of the exercise in the box above the answer at the bottom of the page.

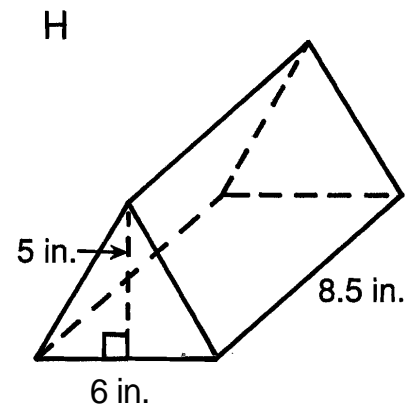
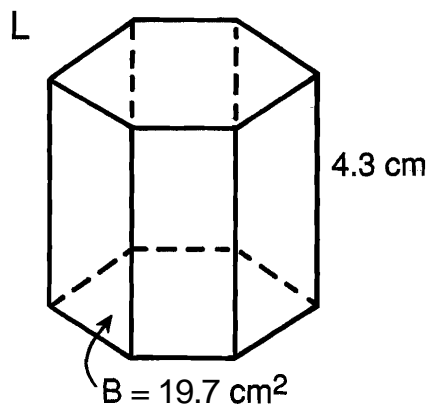
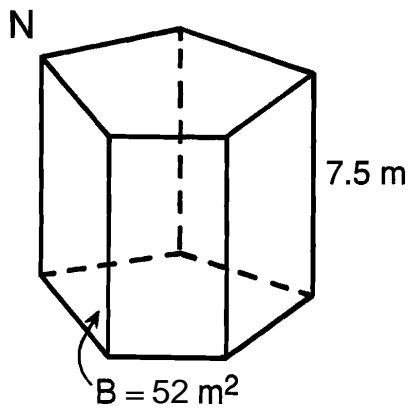
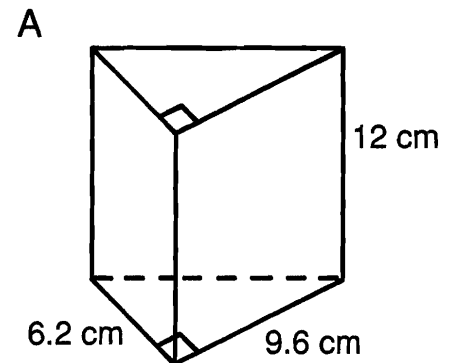
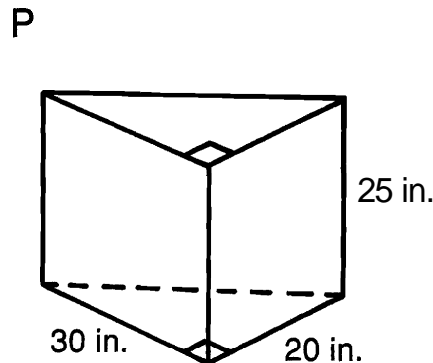
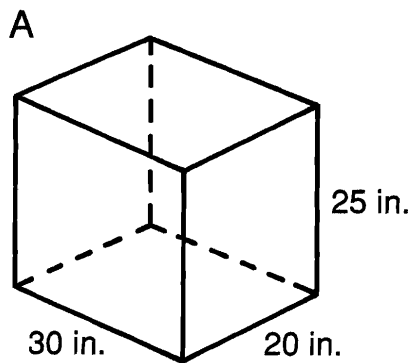
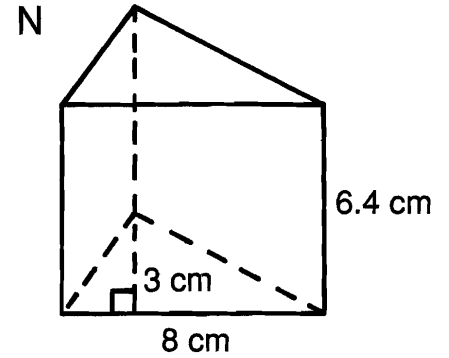
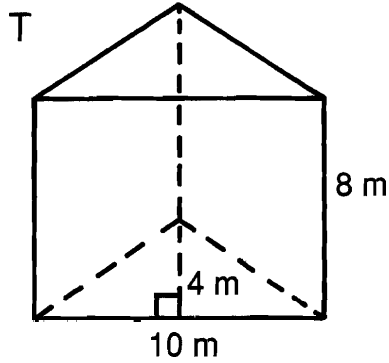
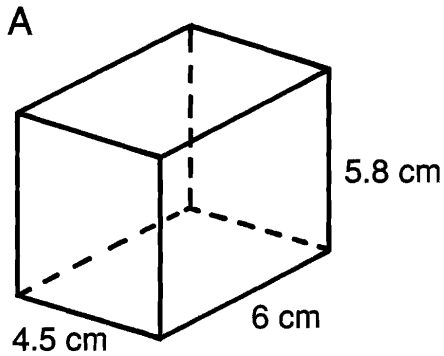

	83.8 cm ³	357.12 cm ³	76.8 cm ³	8,800 in. ³	92.31 cm ³	84.71 cm ³	156.6 cm ³	114.5 in. ³	364.5 m ³	7,500 in. ³	127.5 in. ³	15,000 in. ³	390 m ³	160 m ³	349.22 cm ³	

☆ TRIVIA TEST ☆

1. What Is the Best Way to Paint a Rabbit?

4 7 2 8 8 3 11 5 10 1 11 3 6

2. What Candy Do Kids Eat on the Playground?

11 5 9 5 10 10 1 7 5 9 5 10

Do each exercise and find your answer in the answer column. Write the letter of the answer above the exercise number each time it appears in the code. Use 3.14 for π .

I. Find the volume of each cylinder.

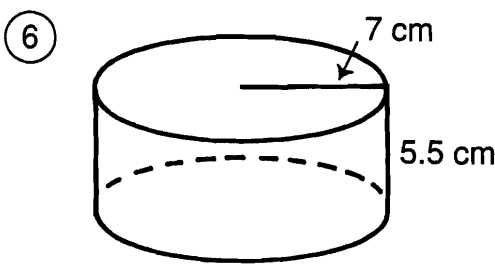
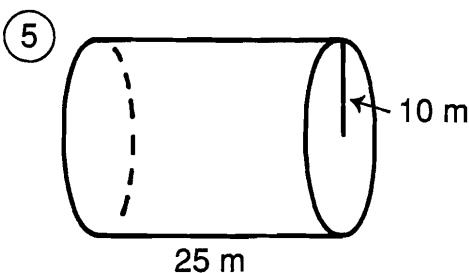
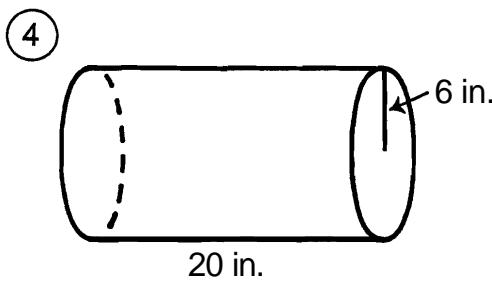
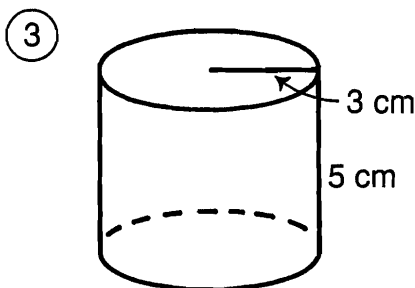
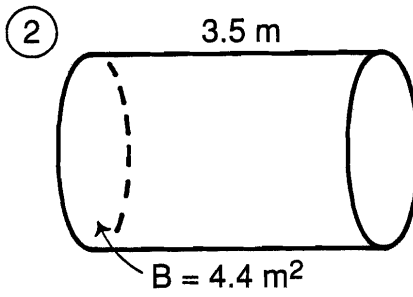
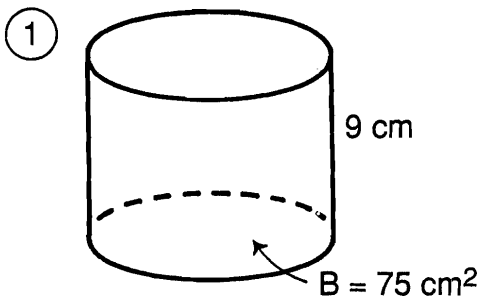

⑦ $r = 8$ in.
 $h = 3$ in.

⑧ $r = 2.5$ mm
 $h = 60$ mm

⑨ $d = 10$ m
 $h = 7.2$ m

Answers

- Ⓜ 814.13 cm^3
- Ⓒ 565.2 m^3
- Ⓝ 381.36 mL
- Ⓐ 141.3 cm^3
- Ⓑ 14.8 m^3
- Ⓜ 602.88 in.³
- Ⓟ 675 cm^3
- Ⓤ 7,490 m^3
- ⓗ 1,177.5 mm^3
- Ⓡ 452.16 mL
- Ⓦ 2,260.8 in.³
- Ⓛ 382.8 cm^3
- Ⓣ 15.4 m^3
- Ⓨ 846.23 cm^3
- Ⓞ 717.8 in.³
- Ⓢ 376.8 cm^3
- ⓖ 1,224.5 mm^3
- ⓔ 7,850 m^3
- ⓓ 614.2 m^3

II. Solve.

⑩ Shawn is making a candle using a cylindrical mold with a radius of 2 cm and a height of 30 cm. How many cubic centimeters of wax are needed for the candle?

⑪ A mug in the shape of a cylinder has a base with a radius of 4 cm. How many milliliters of liquid does it hold if filled to a height of 9 cm?
(Hint: 1 cm^3 holds 1 mL.)

Why Did the Elephant Paint His Toenails Red, Green, Yellow, Blue, and Purple?

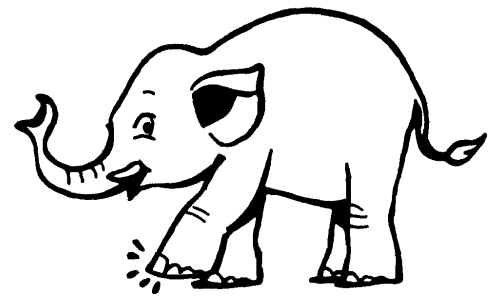

Find each answer in the appropriate set of boxes at the bottom of the page. Write the letter of the exercise in the box containing the answer.

I. Find the length of one side (s) of each square.

Ⓒ

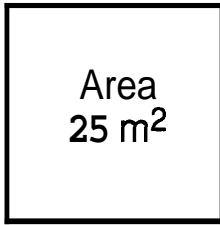

s = _____ m

Ⓘ

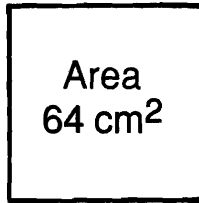

s = _____ cm

Ⓔ

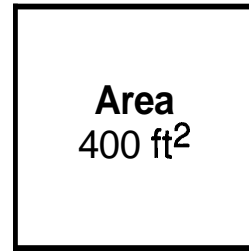

s = _____ ft

II. Find the square root.

Ⓢ $\sqrt{49}$

Ⓛ $\sqrt{16}$

Ⓘ $\sqrt{100}$

Ⓒ $\sqrt{81}$

Ⓔ $\sqrt{36}$

Ⓓ $\sqrt{4}$

Ⓕ $\sqrt{144}$

Ⓝ $\sqrt{1}$

Ⓒ $\sqrt{900}$

Ⓕ $\sqrt{2,500}$

Ⓤ $\sqrt{6,400}$

Ⓓ $\sqrt{10,000}$

III. Simplify.

Ⓔ 15^2

Ⓕ 11^2

Ⓐ 25^2

Ⓔ $\sqrt{121}$

Ⓛ $\sqrt{625}$

Ⓐ $\sqrt{16} + \sqrt{9}$

Ⓔ $\sqrt{36} + \sqrt{64}$

Ⓖ $\sqrt{25} - \sqrt{9}$

Ⓝ $\sqrt{16 + 9}$

Ⓣ $\sqrt{36 + 64}$

Ⓛ $\sqrt{0.25}$

Ⓑ $\sqrt{0.81}$

Ⓙ $\sqrt{0.01}$

Answers for Part I and Part II

7 9 11 12 20 60 30 5 80 4 2 3 50 10 100 6 90 8 1

Answers for Part III

18 10 121 11 12 0.1 14 25 0.5 15 0.4 0.9 225 7 5 715 4 625 2

Why Did the Teacher Assign Extra Homework When She Taught Adolescents?

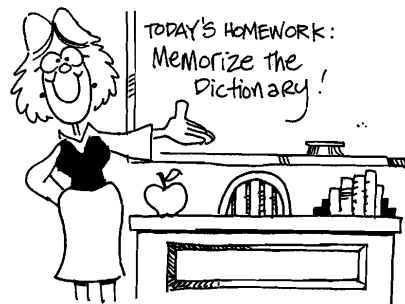

Find which two consecutive whole numbers the square root is between. Write the letter of the exercise on the number line between these two numbers.

Use the top number line for the first set of exercises, and the bottom number line for the rest..

(S) $\sqrt{30}$

(H) $\sqrt{2}$

(T) $\sqrt{45}$

(E) $\sqrt{8}$

(A) $\sqrt{23}$

(N) $\sqrt{120}$

(G) $\sqrt{138}$

(I) $\sqrt{82}$

(W) $\sqrt{11}$

(Y) $\sqrt{70}$

(S) $\sqrt{0.5}$

(R) $\sqrt{59}$

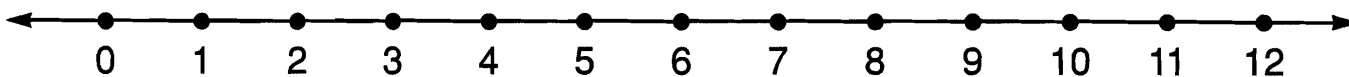

(S) $\sqrt{75}$

(D) $\sqrt{20}$

(O) $\sqrt{3}$

(A) $\sqrt{6}$

(E) $\sqrt{52}$

(S) $\sqrt{95}$

(O) $\sqrt{112}$

(N) $\sqrt{125}$

(D) $\sqrt{14}$

(T) $\sqrt{0.1}$

(A) $\sqrt{33}$

(L) $\sqrt{40}$

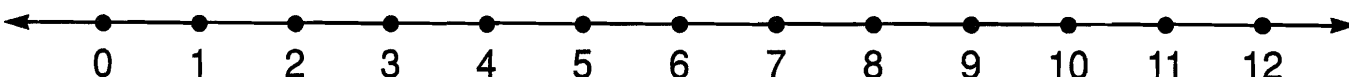

Why Do Adults Complain So Much?

Find the length of the hypotenuse of each right triangle below. Find your answer in the answer column. Write the letter of the answer in the box containing the number of the exercise.

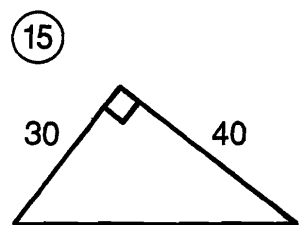
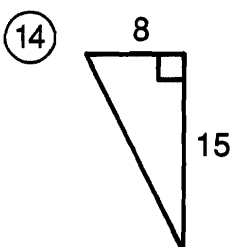
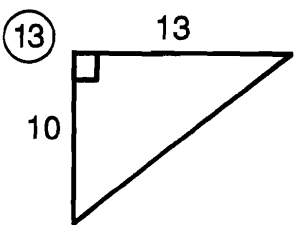
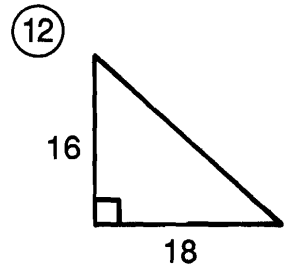
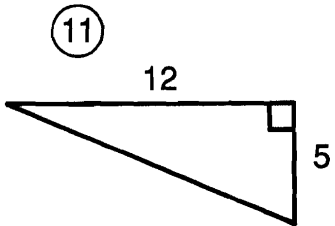
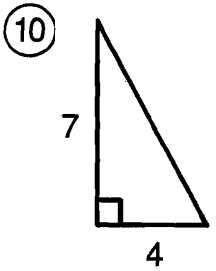
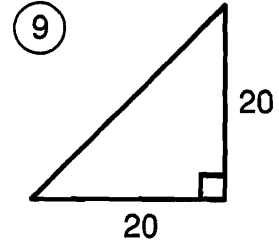
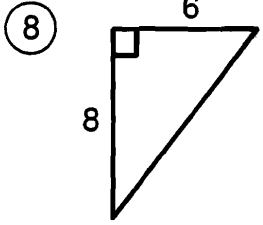
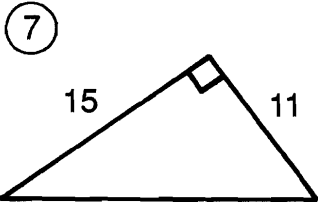
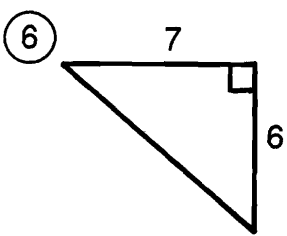
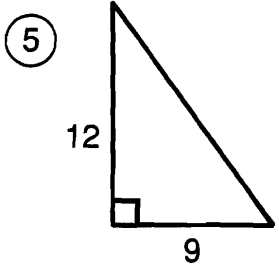
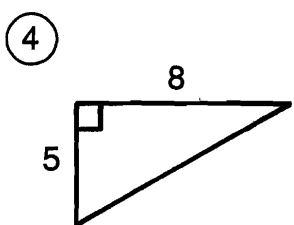
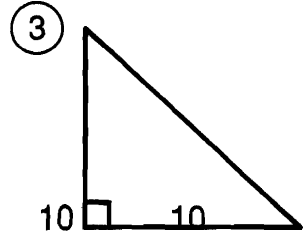
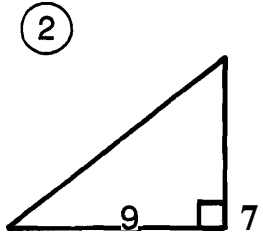
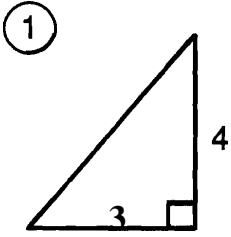

Answers

- (E) $\sqrt{85} \approx 9.2$
- (D) $\sqrt{562} \approx 23.7$
- (Y) $\sqrt{169} = 13$
- (O) $\sqrt{130} \approx 11.4$
- (U) $\sqrt{289} = 17$
- (T) $\sqrt{225} = 15$
- (H) $\sqrt{800} \approx 28.3$
- (E) $\sqrt{25} = 5$
- (N) $\sqrt{580} \approx 24.1$
- (R) $\sqrt{2,500} = 50$
- (S) $\sqrt{346} \approx 18.6$
- (P) $\sqrt{89} \approx 9.4$
- (L) $\sqrt{275} \approx 16.6$
- (G) $\sqrt{65} \approx 8.1$
- (A) $\sqrt{200} \approx 14.1$
- (R) $\sqrt{269} \approx 16.4$
- (A) $\sqrt{100} = 10$

5	9	1	11	3	13	6	10	15	2	8	12	14	4	7
---	---	---	----	---	----	---	----	----	---	---	----	----	---	---

How Would You Describe a Dead Skunk?

Round each answer to the nearest tenth (if necessary). Find each answer at the bottom of the page and cross out the letter above it. When you finish, the answer to the title question will remain.

- 1 Find the length of the hypotenuse of each right triangle.

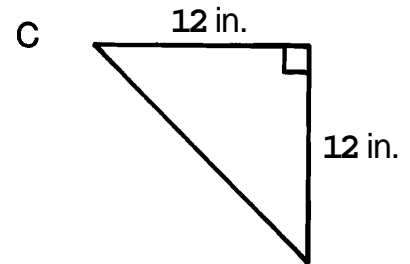
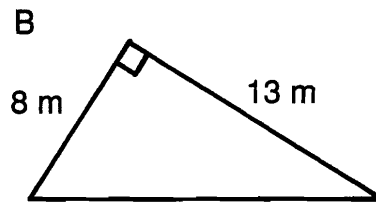
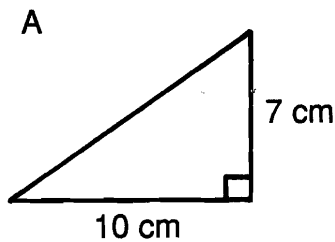

- 2 A rectangle is 6 m wide and 11 m long. How long is the diagonal of the rectangle?

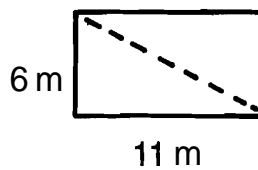

- 6 Kristin and her family left their campsite for a hike. They hiked 5 mi west and then 2 mi north. How far were they from the campsite?

- 3 A television screen may be described in terms of the diagonal measure of its screen. If a TV screen is 20 in. wide and 15 in. high, what is the length of its diagonal?

- 7 The window of a burning building is 40 feet above the ground. The base of a ladder is placed 9 feet from the building. How long must the ladder be to reach the window?

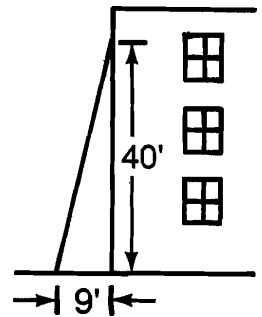

- 4 A quarterback at point A throws the football to a receiver who catches it at point B. How long was the pass?

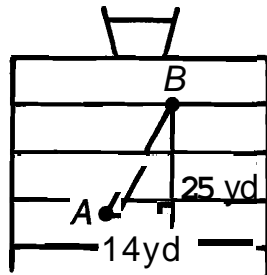

- 8 The bases on a baseball diamond are 90 feet apart. How far is it from home plate to second base?

- 5 A rope is stretched from the top of a 7-foot tent pole to a point on the ground 12 ft from the base of the pole. How long is the rope?

- 9 The lawn in front of Pythagoras Jr. High is in the shape of a rectangle 24 m long and 10 m wide. How many meters shorter is your walk if you walk diagonally across the lawn rather than along two sides of it?

D	E	S	A	X	D	T	N	O	I	S	N	T	A	C	K	T	E
5.4 i	29. yd	15. m	8 m	13.2 m	12.5 m	16.7 in.	41 ft	12.2 cm	6.1 mi	13.9 ft	42.5 ft	127.3 f	28.7 yd	14.4 ft	17.0 in.	129.8 tf	25 in.

Cryptic Quiz

1. What is the opposite of a professional eater?

8.8 19.6 18.5 8.8 10.9 8.8 3.3 9.8 70.7 1.4 70.7 14.5

2. How would you describe a job in the Acme Mitten Co. shipping department?

22.4 16.1 19.2 5 19.6 6 68 6 8 16.1 9.2 70.7 6.3

3. What can be right but never wrong?

8.8 19.6 7.4 8.8 19.6 6 8 70.7

For each exercise, find the missing length. (Refer to the diagram at the right.) Round your answer to the nearest tenth (if necessary) and find it in the code. Each time the answer appears, write the letter of the exercise above it.

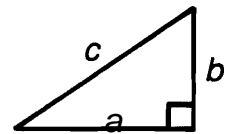

(H) $a = 9, b = 4, c = \underline{\hspace{2cm}}$

(E) $a = 50, b = 50, c = \underline{\hspace{2cm}}$

(O) $a = 8, b = 14, c = \underline{\hspace{2cm}}$

(B) $a = \underline{\hspace{2cm}}, b = 20, c = 30$

(S) $a = \underline{\hspace{2cm}}, b = 3, c = 7$

(V) $a = 6, b = \underline{\hspace{2cm}}, c = 11$

(M) $a = \underline{\hspace{2cm}}, b = 5, c = 12$

(W) $a = 1, b = 1, c = \underline{\hspace{2cm}}$

(G) $a = \underline{\hspace{2cm}}, b = 8, c = 10$

(X) $a = \underline{\hspace{2cm}}, b = 16, c = 25$

(C) $a = 5, b = \underline{\hspace{2cm}}, c = 6$

(A) $a = 2, b = \underline{\hspace{2cm}}, c = 9$

(R) $a = 4, b = \underline{\hspace{2cm}}, c = 15$

(L) $a = \underline{\hspace{2cm}}, b = 15, c = 17$

(I) $a = 12, b = \underline{\hspace{2cm}}, c = 13$

(N) $a = 10, b = \underline{\hspace{2cm}}, c = 22$

What Relation Is a Doorstep to a Doormat?

Round each answer to the nearest tenth (if necessary). Cross out the box containing each answer. When you finish, write the letters from the remaining boxes in the spaces at the bottom of the page.

① For each right triangle, find the length of the side that is not given.

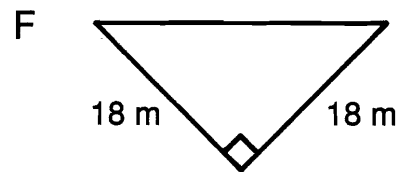
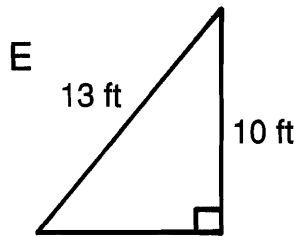
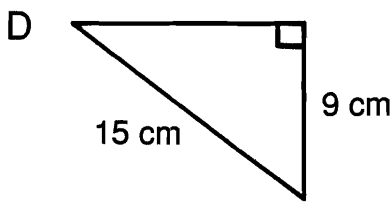
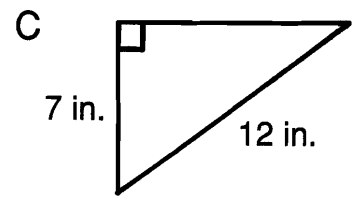
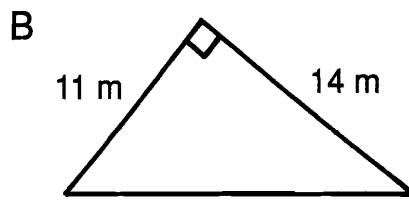
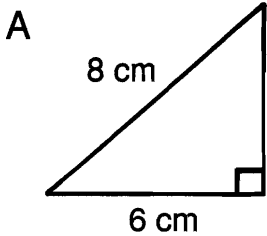

② Yuki just bought a big-screen TV set. The screen has a diagonal measure of 40 in. If the screen is 32 in. wide, how high is it?

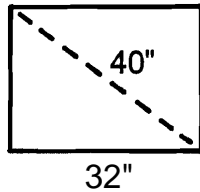

③ The mast of a sailing ship is 20 ft tall. A rope is stretched 26 ft from the top of the mast to a cleat on the deck of the ship. How far is the cleat from the base of the mast?

④ A 25-foot ladder is leaned against a wall. If the base of the ladder is 7 ft from the wall, how high up the wall will the ladder reach?

⑥ Each side of an equilateral triangle measures 12 cm. Find the height, h , of the triangle.

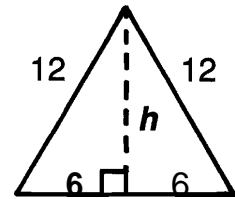

④ Across a 80-meter river, the current carried him 30 m downstream. How far did he swim?

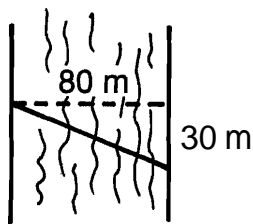

⑦ Two jets left an airport at the same time. One traveled east at 300 miles per hour. The other traveled south at 400 miles per hour. How far apart were the jets at the end of an hour?

PL 85.4 m	DO 12 cm	AS 9.8 cm	OR 24 in.	MA 500 mi	TE 26 in.	AM 5.3 cm	RU 10.4 cm	PF 520 mi
ON 25.5 in.	AR 9.4 in.	UN 17.8 m	PA 16.6 ft	TH 87.1 m	IN 9.7 in.	AT 24 ft	ER 18.5 ft	AN 8.3 ft

--	--	--	--	--	--	--	--	--	--	--

What Does a BONE SPECIALIST Need to Get His Practice Started?



Evaluate each formula below for the given values of the variables.
Find each answer at the left and cross out the letter next to it.
When you finish, the answer to the title question will remain.

E	49
K	145
C	120
A	1,160
I	150
D	490
E	172
O	1,080
R	520
L	68
E	256
B	74
A	924
T	164
S	864

- ① $d = rt$ where d is the distance traveled by an object moving at speed r in time t . Find d if
 $r = 32$ m/sec, $t = 8$ sec. _____ m
-
- ② $E = IR$ where E is the voltage in an electric circuit with current I and resistance R . Find E if
 $I = 2.5$ amperes, $R = 60$ ohms. _____ v
-
- ③ $v = 9.8t$ where v is the speed in meters per second of a free-falling object after t seconds. Find v if
 $t = 5$ sec. _____ m/sec
-
- ④ $S = (n - 2)180$ where S is the sum of the measures of the angles of a polygon with n sides. Find S if
 $n = 8$. _____ °
-
- ⑤ $A = 6e^2$ where A is the surface area of a cube with edge e . Find A if
 $e = 12$ cm. _____ cm²
-
- ⑥ $V = hw^2$ where V is the volume of a prism with a square base of side w and with height h . Find V if
 $h = 10$ cm, $w = 7$ cm. _____ cm³
-
- ⑦ $L = \frac{s^2}{30}$ where L is the approximate length of a skid in feet for a car traveling at s miles per hour. Find L if
 $s = 60$ mi/h. _____ ft
-
- ⑧ $F = 1.8C + 32$ where F is the Fahrenheit temperature equivalent to Celsius temperature C . Find F if
 $C = 20$ °. _____ °F
-
- ⑨ $B = \frac{4(220 - y)}{5}$ where B is the recommended maximum heart rate during exercise for a person y years old. Find B if
 $y = 15$. _____ beats/sec

*** Test of Genius ***

- ① Identical cubes are stacked in the corner of a room as shown. How many cubes are there altogether?

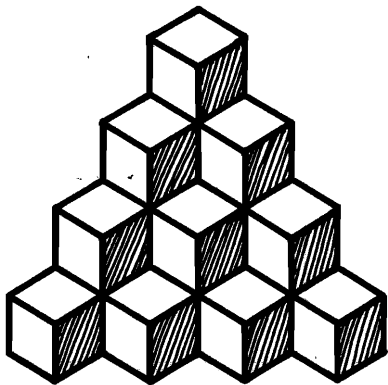

- ② Make this equation correct by changing the position of only one digit.

$$101 - 102 = 1$$

- ③ Ms. Smucker went to a store, spent half of her money and then \$10 more. She went to a second store, spent half of her remaining money and then \$10 more. But she then had no money left. How much money did she have to begin with?

- ④ If 8 widgets equal 4 curlicues and 2 curlicues equal 3 goofups, then 16 widgets equal how many goofups?

- ⑤ Draw the figure below without lifting your pencil from the page or tracing over a line previously drawn.

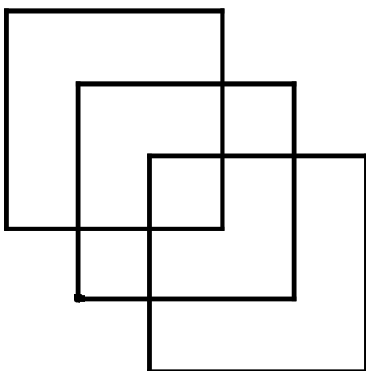

- ⑥ Steven has 9 gold coins that are identical in appearance. However, one coin is counterfeit and weighs slightly less than the others. Using a balance scale, how can he find the counterfeit coin in just two weighings?



- ⑦ In the following addition problem, the letters A, B, and C stand for three different digits. What digit should replace each letter?

$$\begin{array}{r} A B C \\ + A C B \\ \hline C B A \end{array}$$

- ⑧ The teacher noticed there were fewer than 100 students on the playground. When she counted them by 2s, there was 1 student left over. In fact, when she counted them by 3s, 4s, 5s, or 6s, there was always 1 student left over. How many students were on the playground?

- ⑨ In the Hope family there are seven sisters, and each sister has one brother. Including Mr. and Mrs. Hope, how many are in the family?

SCORING KEY

- 8 or 9 — *Superstar Genius*
 6 or 7 — *Star Genius*
 4 or 5 — *Genius*
 3 or less — *Genius of the Future*

How Can You Find a Double-Decker Bus?

For each exercise, circle the letter of the more reasonable measure. Write this letter in the box containing the number of the exercise.

The chart gives an approximate size for each of the most commonly used metric units of length.

Unit	Approximate Size
1 millimeter (mm)	thickness of a dime
1 centimeter (cm)	width of your smallest finger
1 meter (m)	length of a baseball bat
1 kilometer (km)	length of 10 football fields



- | | |
|---|--|
| ① length of an ant
R 5 mm M 5 cm | ② length of a new pencil
A 19 mm O 19 cm |
| ③ height of a basketball hoop
U 30 m H 3 m | ④ distance walked in 1 hour
K 5 km B 50 m |
| ⑤ diameter of a quarter
G 24 cm O 24 cm | ⑥ length of a paper clip
E 3 cm S 30 cm |
| ⑦ length of a tennis court
L 24 m D 24 km | ⑧ distance driven on a freeway in 1 hour
U 85 km A 850 m |
| ⑨ thickness of a nickel
E 20 mm O 2 mm | ⑩ height of a dining table
K 75 mm S 75 cm |
| ⑪ length of an automobile
T 5 m S 50 m | ⑫ length of a marathon race
T 400 m F 40 km |
| ⑬ width of a dollar bill
N 66 cm P 66 mm | ⑬ length of a sheet of typing paper
O 28 cm R 28 mm |
| ⑮ height of a door
M 20 cm B 2 m | ⑮ distance from New York to Los Angeles
D 450 km T 4,500 km |

C O O K F O R T H E B U S T O P

D-7

TOPIC 1a Length

Cryptic Quiz

1 What did the duck say to the store clerk when buying chocolate?

U S **T** **P** **U** **T** **O** **N** **M** **Y** **B** **I** **L** **L**
7.3 5.4 13.6 228 232 8 5.4 228 1.2 71 228 4.6 107 17.4 61 15.7 54 224 42 71 5.0 5.0

2 What did Noah catch many fish during the voyage of the ark?

E **H** **A** **D** **O** **N** **L** **Y** **T** **W** **O** **W** **O** **R** **M** **S**
0.8 150 136 65 7.1 118 107 17.4 5.0 54 6.9 228 113 107 47 113 107 5.9 15.7 13.6

For each exercise, measure the line segment to the nearest millimeter. Express the measurement in millimeters or centimeters, as indicated, and find your answer in the code. Each time the answer appears, write the letter of the exercise above it.

A B C D E F G

- | | | |
|------------------------------------|------------------------------------|------------------------------------|
| ① length $\overline{AB} = 5.4$ cm | ② length $\overline{BD} = 5.9$ cm | ③ length $\overline{CF} = 7.3$ cm |
| ④ length $\overline{AB} = 54$ mm | ⑤ length $\overline{BH} = 17.4$ cm | ⑥ length $\overline{CH} = 15.7$ cm |
| ⑦ length $\overline{AC} = 7.1$ cm | ⑧ length $\overline{EF} = 0.8$ cm | ⑨ length $\overline{GH} = 5.0$ cm |
| ⑩ length $\overline{AC} = 71$ mm | ⑪ length $\overline{EF} = 8$ mm | ⑫ length $\overline{EG} = 42$ mm |
| ⑬ length $\overline{AE} = 13.6$ cm | ⑭ length $\overline{DG} = 65$ mm | ⑮ length $\overline{AD} = 113$ mm |
| ⑯ length $\overline{AE} = 136$ mm | ⑰ length $\overline{CG} = 107$ mm | ⑱ length $\overline{AH} = 224$ mm |

TOPIC 1-b Measuring Line Segments With a Ruler

D-8

Why Are Scales Like Roadmaps?

Do each exercise and find your answer in the set of answers to the right. Write the letter of the answer in the box containing the number of the exercise. If the answer has a ●, shade in the box instead of writing a letter in it.

I. Answer each question.

① How many mm are in 1 cm? <u>10</u>	Answers 1 - 3:
② How many cm are in 1 m? <u>100</u>	T 10 H 100
③ How many m are in 1 km? <u>1,000</u>	E 1,000 R 10,000

II. Complete each statement. You are changing each measure to a smaller unit.

④ 2.75 m = <u>275</u> cm	Answers 4 - 11:
⑤ 8.3 m = <u>830</u> cm	U 3,666 S 27,500
⑥ 41.9 cm = <u>419</u> mm	R 6,250 E 830
⑦ 6.25 cm = <u>62.5</u> mm	● 419 K 2.75
⑧ 1.875 km = <u>1875</u> m	T 40 G 1,875
⑨ 27.5 km = <u>27,500</u> m	W 275 D 41,900
⑩ 0.4 m = <u>40</u> cm	L 18.75 H 82.5
⑪ 3.666 m = <u>36.66</u> dm	● 36.66 C 4,000

III. Complete each statement. You are changing each measure to a larger unit.

⑫ 12.5 mm = <u>1.25</u> cm	Answers 12 - 19:
⑬ 94 mm = <u>9.4</u> cm	H 0.375 R 0.094
⑭ 375 m = <u>0.375</u> km	O 0.25 W 5
⑮ 88 m = <u>0.088</u> km	P 500 O 1.25
⑯ 643 cm = <u>6.43</u> m	● 6.43 E 0.088
⑰ 2.5 cm = <u>0.025</u> m	H 2.5 ● 37.5
⑱ 250 mm = <u>2.5</u> dm	Y 9.4 U 0.0643
⑲ 5,000 m = <u>5</u> km	A 8.8 I 0.025

T H E Y S H O W T H E W E I G H

TOPIC 1-c Renaming Units of Length

D-9

Why Did the Hen Jump Up and Down When She Looked Into the Nest?

Complete each statement, then find your answer in the set of answers to the right. Write the letter of the exercise in the box containing the number of the answer.

① 3.8 m = <u>38</u> dm	Answers
② 3.8 m = <u>380</u> cm	S 0.08 km A 7,400 cm T 7,400 m E 7,400 cm W 60 dam G 60 dam N 60 dam E 1,000 mm S 1,000 mm T 1,000 mm
③ 3.8 m = <u>3,800</u> mm	O 0.08 km C 800 cm A 7,400 cm T 7,400 m E 7,400 cm W 60 dam G 60 dam N 60 dam E 1,000 mm S 1,000 mm T 1,000 mm
④ 490 cm = <u>49</u> dm	O 0.08 km C 800 cm A 7,400 cm T 7,400 m E 7,400 cm W 60 dam G 60 dam N 60 dam E 1,000 mm S 1,000 mm T 1,000 mm
⑤ 490 cm = <u>4.9</u> m	O 0.08 km C 800 cm A 7,400 cm T 7,400 m E 7,400 cm W 60 dam G 60 dam N 60 dam E 1,000 mm S 1,000 mm T 1,000 mm
⑥ 490 cm = <u>0.49</u> hm	O 0.08 km C 800 cm A 7,400 cm T 7,400 m E 7,400 cm W 60 dam G 60 dam N 60 dam E 1,000 mm S 1,000 mm T 1,000 mm
⑦ 27.5 m = <u>2,750</u> cm	O 0.08 km C 800 cm A 7,400 cm T 7,400 m E 7,400 cm W 60 dam G 60 dam N 60 dam E 1,000 mm S 1,000 mm T 1,000 mm
⑧ 27.5 m = <u>2.75</u> dam	O 0.08 km C 800 cm A 7,400 cm T 7,400 m E 7,400 cm W 60 dam G 60 dam N 60 dam E 1,000 mm S 1,000 mm T 1,000 mm
⑨ 27.5 m = <u>0.0275</u> km	O 0.08 km C 800 cm A 7,400 cm T 7,400 m E 7,400 cm W 60 dam G 60 dam N 60 dam E 1,000 mm S 1,000 mm T 1,000 mm
⑩ 9.3 dm = <u>930</u> mm	O 0.08 km C 800 cm A 7,400 cm T 7,400 m E 7,400 cm W 60 dam G 60 dam N 60 dam E 1,000 mm S 1,000 mm T 1,000 mm
⑪ 9.3 dm = <u>93</u> cm	O 0.08 km C 800 cm A 7,400 cm T 7,400 m E 7,400 cm W 60 dam G 60 dam N 60 dam E 1,000 mm S 1,000 mm T 1,000 mm
⑫ 9.3 dm = <u>0.93</u> m	O 0.08 km C 800 cm A 7,400 cm T 7,400 m E 7,400 cm W 60 dam G 60 dam N 60 dam E 1,000 mm S 1,000 mm T 1,000 mm

I T W A S A N E G S I G H T I N G M O M E N T

TOPIC 1-c Renaming Units of Length

D-10

What Did the Finger Scream to the Thumb?

Choose the correct answer for each exercise. Write the letter of the answer in the box containing the number of the exercise. The table below may help you.

Unit	Approximate Size
1 milliliter (mL)	capacity of an eyedropper
1 liter (L)	capacity of a juice carton
1 kiloliter (kL)	capacity of 4 bathtubs

I. Choose the more reasonable estimate of capacity.

- ① a pot for cooking **E** 2 L ② a tablespoon **C** 15 L ③ an automobile gas tank **N** 50 L P 5 kL
- ④ a swimming pool **A** 80 L ⑤ a drinking glass **O** 25 mL ⑥ a water cooler jug **H** 20 L R 2 L

II. Complete each statement.

Answers 7 - 14:

- ⑦ 8.5 L = **8,500** mL B 25 Y 90
 ⑧ 0.4 L = **400** mL U 1.750 W 40,000
 ⑨ 90,000 mL = **90** L O 8,500 F 32
 ⑩ 250 mL = **0.25** L D 4,000 I 0.75
 ⑪ 1.75 kL = **1,750** L S 900 R 175
 ⑫ 40 kL = **40,000** L G 0.25 I 400
 ⑬ 750 L = **0.75** kL T 3.2 U 7.5
 ⑭ 3,200 L = **3.2** kL

III. Solve.

Answers 15 - 16:

- ⑮ Ms Sparkle bought 12 cans of diet soda. Each can contained 350 mL. How many liters of soda did she buy? **4.2** R 48 V 4.2
- ⑯ Chef Pierre made 6.4 L of creamed carrot soup. If it is served in 200-mL cups, how many cups can be filled? **32** L 32 N 54

I M I N G L O V E W I T H Y O U
 I'M IN GLOVE WITH YOU
 D-11 TOPIC 1-d: Capacity

What Do Salmon and Cod Use When They Go to War?

Choose the correct answer for each exercise. Find the letter of the answer in the string of letters near the bottom of the page and CROSS IT OUT each time it appears. When you finish, write the remaining letters in the rectangle at the bottom of the page. The table below may help you.

Unit	Approximate Size
1 milligram (mg)	mass (weight) of a grain of sand
1 gram (g)	mass (weight) of a paperclip
1 kilogram (kg)	mass (weight) of a math textbook

I. Choose the more reasonable estimate of weight.

- ① a nickel **M** 5 g N 5 kg ② a postage stamp **A** 60 g Y 60 mg ③ a bowling ball **B** 7 kg K 70 kg
- ④ a lemon **X** 12 g W 120 g ⑤ a 12-year-old child **Z** 40 kg I 4 kg ⑥ a postcard **Q** 75 g G 750 mg

II. Complete each statement.

Answers 7 - 14:

- ⑦ 6.5 g = **6,500** mg H 490 L 0.133
 ⑧ 0.8 g = **800** mg J 800 C 60,000
 ⑨ 4,900 mg = **4.9** g T 725 V 6,500
 ⑩ 133 mg = **0.133** g F 2.5 K 13.3
 ⑪ 7.25 kg = **7,250** g P 4.9 U 7,250
 ⑫ 60 kg = **60,000** g S 0.6 D 80
 ⑬ 250 g = **0.25** kg E 0.25 I 65
 ⑭ 80,000 g = **80** kg

III. Solve.

Answers 15 - 16:

- ⑮ An average orange weighs 270 g. How many kilograms does a bag of 8 oranges weigh? **2.16** T 1.96 O 800
- ⑯ A vitamin tablet weighs 1.2 g. It contains 150 mg of Vitamin C and 250 mg of B Complex vitamins. How many milligrams of other ingredients are in the tablet? **800** F 920 R 2.16

Answer to puzzle: **FISH TANKS**

TOPIC 1-e: Weight

D-12

Why Did the Ice Skater Tell Jokes While Performing?

Do each exercise and find your answer in the set of answers to the right. Write the letter of the answer in each box containing the number of the exercise. If the answer has a ●, shade in each box containing that exercise number.

I. Complete each statement.

- ① 8.3 kg = **8,300** g ② 830 mg = **0.83** g ③ 309 ④ 2.75 g = **2.75** kg ⑤ 4,000,000 mg = **4** kg ⑥ 66,000 mL = **66** L ⑦ 3.09 L = **3,090** mL ⑧ 0.04 kL = **40,000** mL

II. Solve.

- ⑮ A jar of sweet pickles contains 650 g of pickles. There are 12 jars in a case. How many kilograms of pickles are in a case? **7.8** kg
- ⑯ A costume designer bought 1.4 kg of sequins to make a crown and 400 g to make a cape. How many grams of sequins were left? **750** g
- ⑰ A gasoline can was filled with 17.5 L of gasoline. A lawnmower fuel tank that holds 1.4 L has been filled 8 times from the gasoline can. How much gasoline is left in the can? **6.3** L

D-13

TOPIC 1-f: Review: Capacity and Weight

TEX BOOKS
 K S H T R O F E W F X V B E D O Y W O N A S E
 14 11 2 13 5 8 16 13 9 6 16 1 13 16 10 3 15 15 3 14 7 13 8 12 4 6 14 15
 S H E W A S J U S T S K I D D I N G A R O U N D

14 min 30 s
1:55
15 min 26 s
3 d 15 h
420
3 min 28 s
6 h 28 min
3
6 h 15 min
4 min 40 s
3,920
72
240
2 d 17 h
3 min 42 s
1:20
12 h 28 min
9 h 51 min
310
12 h 42 min
14 min 56 s
9
4,320
11 h
10 h 58 min
150
6 h 40 min
2:15

What Should You Study to Learn How to be a Cowboy?

Cross out the letter next to each correct answer. When you finish, the answer to the title question will remain.

I. Complete each statement.

- ① 4 h = **240** min ② 7 min = **420** sec
 ③ 2 h 30 min = **150** min ④ 5 min 10 sec = **310** sec
 ⑤ 180 min = **3** h ⑥ 540 sec = **9** min
 ⑦ 80 min = **1** h **20** min ⑧ 135 sec = **2** min **15** sec
 ⑨ 3 d = **72** h ⑩ 3 d = **4,320** min

II. Add or subtract. Simplify if possible.

- ⑪ 2 h 30 min + 3 h 45 min = **6 h 15 min**
- ⑫ 5 min 40 s + 8 min 50 s = **14 min 30 s**
- ⑬ 7 h 8 min + 2 h 43 min = **9 h 51 min**
- ⑭ 8 min 10 s - 3 min 30 s = **4 min 40 s**
- ⑮ 12 h 25 min - 5 h 45 min = **6 h 40 min**
- ⑯ 32 min 50 s - 17 min 24 s = **15 min 26 s**
- ⑰ 6 h 47 min + 4 h 13 min = **11 h**
- ⑱ 9 min - 5 min 32 s = **3 min 28 s**
- ⑲ -5 d 11 h - 2 d 17 h = **24 17 h**

III. Solve.

- ⑳ It takes 15 h 20 min to travel from Los Angeles to Salt Lake City by train. It takes only 2 h 38 min to fly between the two cities. How much longer does the train take? **12 h 42 min**

TOPIC 1-g: Time

D-14

What Has Four Legs and Flies?

This title question has TWO different answers. Part I gives you one answer and Part II gives you the other. Follow the directions for each part.

I. Identify each measurement that is marked with a letter. Write each letter in the box that contains the corresponding measurement.

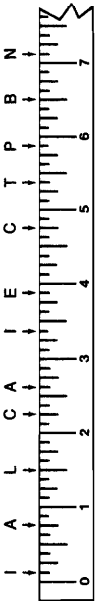

2 $\frac{5}{8}$ in.	1 $\frac{1}{2}$ in.	1 $\frac{5}{8}$ in.	1 in.	4 $\frac{3}{4}$ in.	3 $\frac{1}{8}$ in.	1 in.	3 $\frac{3}{8}$ in.	1 $\frac{1}{4}$ in.	2 $\frac{1}{4}$ in.	1 $\frac{3}{4}$ in.	1 $\frac{5}{8}$ in.	3 $\frac{3}{8}$ in.	3 $\frac{1}{4}$ in.	6 $\frac{1}{2}$ in.	1 $\frac{1}{2}$ in.	3 $\frac{7}{8}$ in.
A	P	I	C	N	I	C	T	A	B	L	E					

II. For each exercise, measure the line segment to the nearest $\frac{1}{8}$ inch. Write the letter of the exercise in the box marking the measurement.

A	B	C	D	E	F	G	I
① $1\frac{1}{4}$ in.	② $2\frac{3}{8}$ in.	③ $3\frac{1}{2}$ in.	④ $4\frac{3}{8}$ in.	⑤ $5\frac{1}{8}$ in.	⑥ $6\frac{3}{8}$ in.	⑦ $7\frac{1}{8}$ in.	⑧ $8\frac{3}{8}$ in.
⑨ $9\frac{1}{8}$ in.	⑩ $10\frac{3}{8}$ in.	⑪ $11\frac{1}{8}$ in.	⑫ $12\frac{3}{8}$ in.	⑬ $13\frac{1}{8}$ in.	⑭ $14\frac{3}{8}$ in.	⑮ $15\frac{1}{8}$ in.	⑯ $16\frac{3}{8}$ in.
T	W	O	P	A	I	R	S
⑰ $17\frac{1}{8}$ in.	⑱ $18\frac{3}{8}$ in.	⑲ $19\frac{1}{8}$ in.	⑳ $20\frac{3}{8}$ in.	㉑ $21\frac{1}{8}$ in.	㉒ $22\frac{3}{8}$ in.	㉓ $23\frac{1}{8}$ in.	㉔ $24\frac{3}{8}$ in.
⑳	㉑	㉒	㉓	㉔	㉕	㉖	㉗
T	W	O	P	A	I	R	S
㉘	㉙	㉚	㉛	㉜	㉝	㉞	㉟
T	W	O	P	A	I	R	S
㊱	㊲	㊳	㊴	㊵	㊶	㊷	㊸
T	W	O	P	A	I	R	S

D-15 TOPIC 2a: Measuring Line Segments With a Ruler

Why Do Elephants Lift Weights?

Measure each line segment below to the nearest one-eighth inch. Find your answer in the answer column. Write the letter of the exercise in the box containing the number of the answer.

①	②	③	④	⑤	⑥	⑦	⑧	⑨	⑩	⑪	⑫	⑬	⑭	⑮	⑯	⑰	⑱
3 $\frac{7}{8}$ in.	2 $\frac{7}{8}$ in.	7 $\frac{7}{8}$ in.	5 $\frac{1}{4}$ in.	4 $\frac{1}{4}$ in.	4 $\frac{3}{8}$ in.	3 $\frac{1}{8}$ in.	5 $\frac{1}{8}$ in.	3 $\frac{5}{8}$ in.	3 $\frac{3}{4}$ in.	2 $\frac{1}{2}$ in.	1 $\frac{5}{8}$ in.	1 $\frac{3}{8}$ in.	1 $\frac{3}{4}$ in.	4 $\frac{1}{2}$ in.	2 $\frac{5}{8}$ in.	2 in.	4 $\frac{3}{8}$ in.
⑳	㉑	㉒	㉓	㉔	㉕	㉖	㉗	㉘	㉙	㉚	㉛	㉜	㉝	㉞	㉟	㊱	㊲
3 $\frac{3}{8}$ in.	2 $\frac{3}{8}$ in.	3 $\frac{1}{8}$ in.	4 $\frac{1}{8}$ in.	5 $\frac{1}{8}$ in.	6 $\frac{1}{8}$ in.	7 $\frac{1}{8}$ in.	8 $\frac{1}{8}$ in.	9 $\frac{1}{8}$ in.	10 $\frac{1}{8}$ in.	11 $\frac{1}{8}$ in.	12 $\frac{1}{8}$ in.	13 $\frac{1}{8}$ in.	14 $\frac{1}{8}$ in.	15 $\frac{1}{8}$ in.	16 $\frac{1}{8}$ in.	17 $\frac{1}{8}$ in.	18 $\frac{1}{8}$ in.
㊳	㊴	㊵	㊶	㊷	㊸	㊹	㊺	㊻	㊼	㊽	㊾	㊿	㋀	㋁	㋂	㋃	㋄
㊱	㊲	㊳	㊴	㊵	㊶	㊷	㊸	㊹	㊺	㊻	㊼	㊽	㊾	㊿	㋀	㋁	㋂

TO GET THEIR EXTRA SIZE

TOPIC 2a: Measuring Line Segments With a Ruler D-16

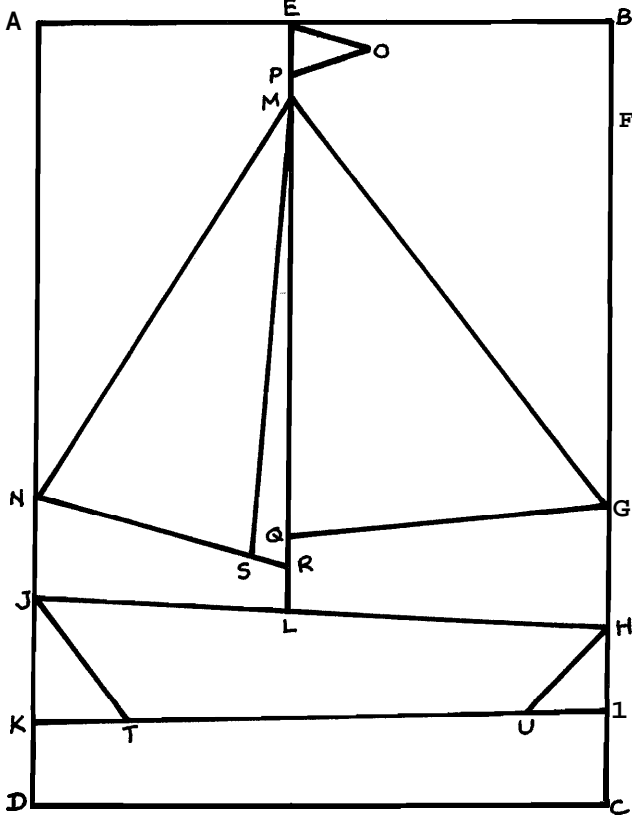

D-17 TOPIC 2a: Measuring Line Segments With a Ruler

What Is the Title?

TO FIND THE TITLE OF THIS PICTURE:
Do each exercise below. Find your answer in the code and write the letter of the exercise above it. (Each answer appears only once.)

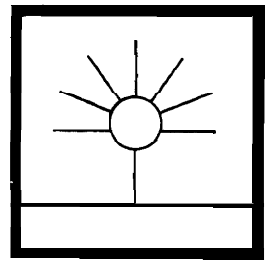

CODED TITLE:

S	f	I	D	E	R	D	O	/	N	G	
72	1;20	5;9	11;2	3	15	98	4	3;1	18	12	61
A	H	A	N	D	S	T	A	N	D		
8;16	24	7	5	29	126	36	10;6	60	1;7	8	100

- I. Answer each question.
- ① How many inches are in 1 foot? 12 ② How many feet are in 1 yard? 3 ③ How many inches are in 1 yard? 36
- II. Complete each statement. You are changing each measure to a smaller unit.
- ④ 2 ft = 24 in.
⑤ 5 ft = 60 in.
⑥ 1 ft 6 in. = 18 in.
⑦ 8 ft 4 in. = 100 in.
⑧ 5 yd = 15 ft
⑨ 9 yd 2 ft = 29 ft
⑩ 20 yd 1 ft = 61 ft
⑪ 2 yd = 72 in.
⑫ 3 yd 18 in. = 126 in.
- III. Complete each statement. You are changing each measure to a larger unit.
- ⑬ 48 in. = 4 ft
⑭ 19 in. = 1 ft 7 in.
69 in. = 5 ft 9 in.
⑮ 24 ft = 8 yd
⑯ 10 ft = 3 yd 1 ft
⑰ 35 ft = 11 yd 2 ft
⑱ 180 in. = 5 yd
⑲ 56 in. = 1 yd 20 in.
⑳ 366 in. = 10 yd 6 in.

TOPIC 2W: Renaming Units of Length D-18

NOTE: Students are to estimate, not measure, these angles. You may want to provide 45° , 90° , and 135° angles for them to use as models.

Why Did the Brontosaurus Need Band-Aids?

For each exercise, circle the letter of the best estimate. Write this letter in the box containing the number of the exercise.

1 $m\angle P$ is about
 B 35° S 70°

2 $m\angle X$ is about
 T 65° Q 30°

3 $m\angle V$ is about
 E 140° J 95°

4 $m\angle G$ is about
 L 55° I 25°

5 $m\angle K$ is about
 F 30°

6 $m\angle W$ is about
 R 155° C 110°

7 $m\angle BAC$ is about
 S 40° P 15°

8 $m\angle CAD$ is about
 U 65° I 90°

9 $m\angle BAD$ is about
 G 100° O 130°

10 $m\angle POR$ is about
 M 160° F 120°

11 $m\angle POQ$ is about
 V 40° N 15°

12 $m\angle QOR$ is about
 P 105° B 140°

13 $m\angle X$ is about
 P 35° H 60°

14 $m\angle Y$ is about
 S 45° L 25°

15 $m\angle Z$ is about
 D 75° G 40°

10	2	6	13	11	9	14	5	12	3	7
F	O	R	H	N	O	S	O	R	E	S

FOR HIS DINO SORES

D-27 TOPIC 3-c: Estimating Angles

Books Never Written

Beginning Your Exercise Program by B E N D O V E R
 57° 99° 119° 137° 173° 89° 99° 33°

Checking Your Homework by R U W R I G H T
 33° 76° 156° 33° 47° 125° 28° 14°

How to Lead the Band by M A R S A L O G
 38° 62° 33° 90° 28° 62° 41° 173° 119° 125°

ABOVE ARE THE TITLES OF THREE "BOOKS NEVER WRITTEN." TO DECODE THE NAMES OF THEIR AUTHORS:

Measure each angle below and find your answer in the code. Each time the answer appears in the code, write the vertex letter of that angle above it.

TOPIC 3-d: Measuring Angles With a Protractor D-28

What Happens When Cupid Shoots an Arrow?

Use a protractor to construct the angles below. Each side you draw will pass through a number. Write the vertex letter of the angle in the box containing this number.



8 45° 14 60° 12 120°

3 33° 6 97° 7 139°

2 21° 13 72° 7 16°

3 56° 10 108° 9 154°

1	2	3	4	5	6	7	8	9	10	11	12	13	14
H	E	M	R	S.	S	O	M	E	O	N	E		

HE MRS. SOMEONE

D-29 TOPIC 3-e: Drawing Angles With a Protractor

Why Is a Party Like Pouring Oil Into a Car?

Do each exercise and find your answer at the bottom of the page. Write the letter of the exercise in the box above or below the answer.

- Find the measure of the angle that is complementary to the angle having the measure given.

(E) 20° 70° (H) 23° (S) 76° (E) 81° 9° (T) 45° 45°
- Find the measure of the angle that is supplementary to the angle having the measure given.

(R) 120° 60° (E) 56° 124° (I) 29° 151° (U) 162° 18° (H) 83° 97°
- Find the angle measure that is not given.

(N) 30° (E) 62° (T) 47°

80° 28° 43°

(L) 108° 72° (W) 116° 64° (F) 35° 145°

(E) 56° 34° (B) 67° 113° (N) 73° 17°

151°	78°	64°	56°	62°	45°	124°	145°	17°	70°	133°	9°							
I	T	S	W	H	E	R	E	T	H	E	F	U	N	N	E	L	B	E
43°	125°	97°	60°	36°	23°	37°	18°	30°	108°	113°								

TOPIC 3-f: Complementary and Supplementary Angles D-30

How Did the Judge Find Out About the Rotten Milk?

Do each exercise and find your answer in the Code Key. Notice the letter next to the answer. Write this letter in the box containing the number for the exercise.

I. Complete each statement.

- Two angles are complementary if the sum of their measures is 90° .
- Two angles are supplementary if the sum of their measures is 180° .
- The complement of a 30° angle has a measure of 60° .
- The supplement of a 65° angle has a measure of 115° .

II. Find the measure of each numbered angle.

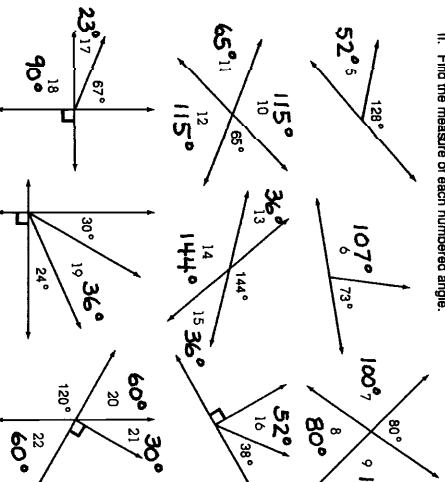

CODE KEY	CODE
23	D
30	Q
36	T
52	A
60	R
65	U
80	I
90	O
100	H
107	S
115	E
144	W
180	N



13 7 12 3 10 14 16 6 18 17 1 20 8 2 19 9 4 21 11 5 22 15
T H E R E W A S O D O R I N T H E Q U A R T

D-31

TOPIC 3-9: Related Angles Formed by Intersecting Lines

Why Couldn't the Two Elephants Go Swimming Together?

Give the measure of each numbered angle. Find your answer in the Code Key and notice the letter next to it. Write this letter in the box containing the number of the angle. (Assume that lines in each figure that do not intersect are parallel.)

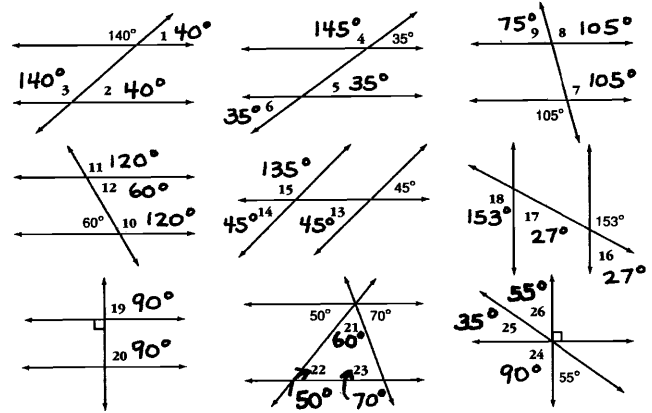

CODE KEY	CODE
27	A
35	O
40	R
45	Y
50	I
55	P
60	T
70	U
75	F
90	N
105	H
120	E
135	K
140	L
145	G
153	D

12 7 10 14 8 16 18 6 20 3 13 25 19 11 26 17 22 1 18 5 9 21 23 24 15 4
T H E R E W A S O D O R I N T H E Q U A R T

D-33

TOPIC 3-1: Related Angles Formed by Parallel Lines and Transversals

What Is The Biggest Problem of Miners?

Circle the number-letter pair of each TRUE statement. For these pairs, write the letter in the matching numbered box at the right.

1 2 3 4 5 6 7 8 9 10 11 12 13 14 15 16 17 18
T H E Y G E T C O A L F R O M T H E E

I. Use the figure below, in which $\overline{EF} \parallel \overline{BH}$. You should find 11 true statements.

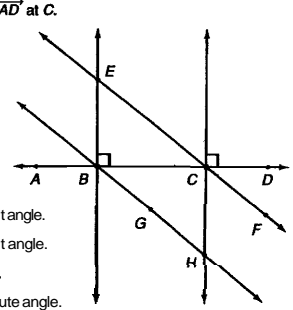

- 7-E \overline{EF} intersects \overline{AD} at C.
- 11-O $\overline{EB} \perp \overline{AC}$
- 2-H $\overline{FC} \parallel \overline{HG}$
- 17-E $\overline{HC} \perp \overline{DB}$
- 1-T $\overline{EB} \parallel \overline{CH}$
- 3-A $\overline{BG} \perp \overline{CH}$
- 16-S $\overline{CF} \parallel \overline{BE}$
- 12-A $\angle EBC$ is a right angle.
- 18-G $\angle DCE$ is a right angle.
- 3-E $m\angle HCB = 90^\circ$.
- 8-T $\angle FCH$ is an acute angle.
- 16-E $\angle LECH$ is an obtuse angle.
- 14-P $\angle ABE$ is an acute angle.
- 4-Y Perpendicular lines intersect to form right angles.
- 18-T Parallel lines never intersect.
- 6-L $m\angle DCH = m\angle EBH$

TOPIC 3-4: Parallel and Perpendicular Lines

D-32

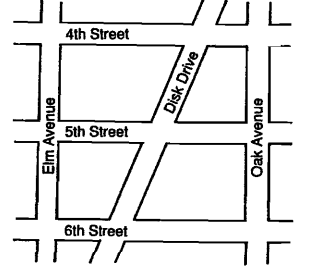

- II. Use the figure above. You should find 4 true statements.
- 13-L 5th Street is parallel to 6th Street.
 - 6-G 6th Street is perpendicular to Elm Avenue.
 - 10-S Elm Avenue is parallel to Disk Drive.
 - 15-F 4th Street and Oak Avenue intersect to form right angles.
 - 9-N Elm Avenue is perpendicular to Oak Avenue.
 - 10-C Elm Avenue is parallel to Oak Avenue.

What Did the Boy Candy Say to the Girl Candy?

Do each exercise and find your answer in the set of answers to the right. Write the letter of the answer in each box containing the number of the exercise. If the answer has a ●, shade in each box containing that exercise number.

I. Classify each triangle two ways.

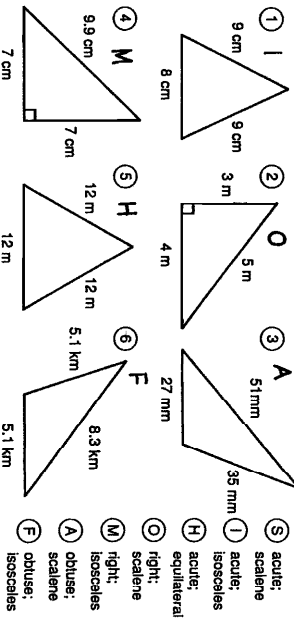

- (S) acute; scalene
- (L) acute; isosceles
- (H) acute; equilateral
- (O) right; scalene
- (M) right; isosceles
- (A) obtuse; scalene
- (E) obtuse; isosceles

II. Find the measure of the third angle in each triangle.

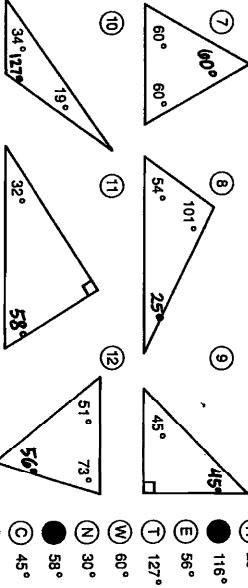

- (H) 25°
- (●) 116°
- (E) 56°
- (N) 30°
- (W) 60°
- (T) 127°
- (M) 49°
- (●) 58°
- (C) 45°
- (L) 40°

13. Two angles of a triangle have equal measures. If the third angle measures 120° , what is the measure of each of the equal angles? 30°

7 12 11 3 8 12 11 4 1 13 10 11 6 2 8 11 21 3 8 5 11 2 10 5 12 8
W E A R E M I N T F O R E A C H O T H E R

TOPIC 3-1: Triangles

D-34

What Do You Get When You...

1. Cross two ducks with a match?

Answer: **FIRE QUACKERS**
 37° 57° 99° 67° 104° 78° 59° 113° 42° 53° 67° 99° 18°

2. Cross a stick of dynamite with a lemon pie?

Answer: **ABOOM MERINGUE**
 113° 68° 83° 34° 34° 54° 38° 54° 87° 99° 57° 90° 36° 59° 67°

Find the angle measures indicated. Look for each answer in the code. Each time the answer appears, write the letter of the exercise above it.

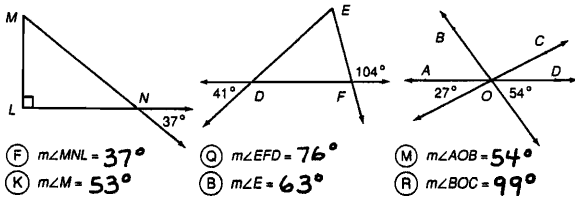
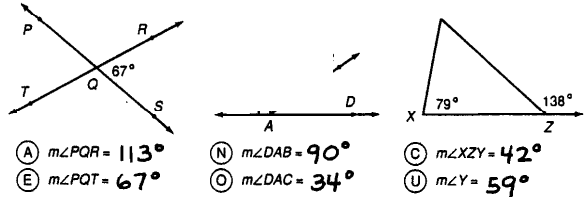
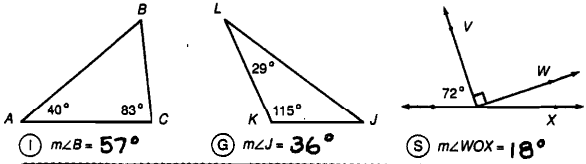

D-35

TOPIC 3-k: Review Related Angles

Daffynition Decoder

For each exercise, find the angle measure indicated. Look for each answer in the code. Each time the answer appears, write the letter of the exercise above it.

Warehouse:

W H A T Y O U S S A Y W H E N L O S T
 105° 40° 36° 78° 151° 55° 45° 146° 36° 151° 105° 40° 135° 42° 34° 34° 55° 146° 78°
N O T S C R A M B L E D O R F I E D
 42° 55° 78° 146° 116° 56° 36° 74° 28° 34° 195° 100° 55° 56° 60° 56° 98° 195° 100°

Explain:

- (H) If $m\angle 1 = 50^\circ$, then $m\angle 2 = 40^\circ$
- (F) If $m\angle 3 = 120^\circ$, then $m\angle 4 = 60^\circ$
- (O) If $m\angle 2 = 35^\circ$, then $m\angle 1 = 55^\circ$
- (E) If $m\angle 4 = 45^\circ$, then $m\angle 3 = 135^\circ$
- (B) If $m\angle 6 = 29^\circ$, then $m\angle 8 = 29^\circ$
- (Y) If $m\angle 6 = 29^\circ$, then $m\angle 5 = 151^\circ$
- (C) If $m\angle 5 = 116^\circ$, then $m\angle 7 = 116^\circ$
- (L) If $m\angle 8 = 82^\circ$, then $m\angle 7 = 98^\circ$
- (A) If $m\angle 11 = 144^\circ$, then $m\angle 10 = 36^\circ$
- (N) If $m\angle 8 = 78^\circ$ and $m\angle 9 = 60^\circ$, then $m\angle 10 = 42^\circ$
- (D) If $m\angle 9 = 47^\circ$ and $m\angle 10 = 33^\circ$, then $m\angle 8 = 100^\circ$
- (U) If $m\angle 10 = 45^\circ$ and $m\angle 3 = 90^\circ$, then $m\angle 9 = 45^\circ$
- (M) If $m\angle 6 = 66^\circ$ and $m\angle 9 = 40^\circ$, then $m\angle 10 = 74^\circ$
- (T) If $m\angle 11 = 130^\circ$ and $m\angle 9 = 52^\circ$, then $m\angle 8 = 78^\circ$
- (W) If $m\angle 8 = 81^\circ$ and $m\angle 9 = 24^\circ$, then $m\angle 11 = 105^\circ$
- (R) If $m\angle 2 = 56^\circ$, then $m\angle 4 = 56^\circ$
- (I) If $m\angle 1 = 56^\circ$, then $m\angle 4 = 34^\circ$
- (S) If $m\angle 1 = 56^\circ$, then $m\angle 3 = 146^\circ$

TOPIC 3-k: Review Related Angles

D-36

NOTE: Students are to assume that sides that appear parallel are parallel, and sides that appear to be perpendicular are perpendicular. Encourage students to write the name of each figure under it.

Can a Polar Bear Go On a Safari?

Write the name that best describes each quadrilateral. (Put each quadrilateral in the smallest or most exact class to which it belongs.) Write the letter of the exercise in the box containing the number of the answer.

(I) 10	(O) 2	(W) 18	(2) rectangle
(A) 6	(S) 11	(O) 17	(15) trapezoid
(R) 9	(N) 1	(K) 15	(10) square
(S) 5	(A) 8	(N) 16	(18) parallelogram
			(9) rectangle
			(6) trapezoid
			(17) parallelogram
			(11) rhombus
			(3) square
			(13) trapezoid
			(4) parallelogram
			(7) rectangle
			(15) parallelogram
			(1) rectangle
			(9) rhombus
			(12) trapezoid
			(16) trapezoid
			(5) square
			(14) rectangle
			(8) rhombus

1 2 3 4 5 8 7 8 9 10 11 12 13 14 15 16 17 18
N O T S A F A R I S I K N O W

D-37

TOPIC 3-l: Quadrilaterals

Why Was Cinderella Kicked Off the Baseball Team?

For each exercise, circle the letter of each figure that belongs in the category named. Arrange these letters to form a word. Then write this word on the line next to the name of the category.

(You may assume the following: sides that appear parallel are parallel; sides that appear perpendicular are perpendicular; sides that appear congruent are congruent.)

1 quadrilaterals: **SHE**

(E) (W) (S) (T) (E) (H)

2 parallelograms: **RAN**

(A) (I) (N) (C) (R)

3 rectangles: **AWAY**

(O) (T) (A) (Y) (A) (W)

4 rhombuses: **FROM**

(S) (M) (C) (E) (F) (R)

5 squares: **THE**

(A) (E) (B) (T) (H) (S)

6 trapezoids: **BALL**

(A) (G) (L) (B) (I) (L)

TOPIC 3-l: Quadrilaterals

D-38

Why Didn't the Snobbish Potatoes Want Their Daughter to Marry a News Broadcaster?

Under each figure, circle the number-letter combination next to each word that correctly names the figure. Write the letter in the matching numbered box at the bottom of the page.

1 7 3

5-A parallelogram 5- parallelogram 4-U quadrilateral
 16-O rectangle 13-I rectangle 21-E parallelogram
 19-F square 4-D rhombus 1-H trapezoid

4 5 6

20-N parallelogram 2-E quadrilateral 19-O parallelogram
 11-T rectangle 24-V parallelogram 15-L rectangle
 23-A square 8-P rhombus 6-S rhombus

7 8 9

13-A quadrilateral 17-M rectangle 21-E parallelogram
 26-B parallelogram 10-P square 18-I rhombus
 7-N trapezoid 14-S trapezoid 8-J trapezoid

10 11 12

4-W quadrilateral 22-T quadrilateral 10-S rectangle
 12-O parallelogram 15-C rhombus 18-M rhombus
 24-N trapezoid 3-B square 24-T square

1 2 3 4 5 6 7 8 9 10 11 12 13 14 15 16 17 18 19 20 21 22 23 24 25 26
 H E W A S J U S T A C O M M O N T A T E R

D-39

TOPIC 3-I Quadrilaterals

Why Do Ants Visit the Zoo on Cold Days?

Write the word missing from each statement in the boxes next to the statement. Notice which letters are in numbered boxes. Write each of these letters in the matching numbered box at the bottom of the page.

A

1 A triangle is a _____ with three sides and three angles.

2 A polygon with four sides and four angles is a _____.

3 A polygon with five sides and five angles is a _____.

4 A polygon with six sides and six angles is a _____.

5 An octagon is a polygon with eight sides and eight _____.

6 A polygon with ten sides and ten angles is a _____.

7 In the set of figures above, Figure A is a _____.

8 Figure B is an _____.

9 Figure C is a _____.

10 Figure D is a _____.

11 The point of intersection of two sides of a polygon is called a _____.

12 A line segment (not a side) connecting two vertices of a polygon is called a _____.

13 A polygon with all sides the same length and all angles the same measure is called a _____ polygon.

POLYGON
 QUADRILATERAL
 PENTAGON
 HEXAGON
 ANGLES
 DECAGON
 HEXAGON
 OCTAGON
 PENTAGON
 DECAGON
 VERTEX
 DIAGONAL
 REGULAR

1 2 3 4 5 6 7 8 9 10 11 12 13 14 15 16 17 18 19 20 21
 T O G E T N E A R T H E A N T H E A T E R

TOPIC 3-m Polygons

D-40

NOTE: Part II of this puzzle introduces students to the concept of corresponding parts of congruent triangles.

Why Couldn't Orgo Buy a Round Trip Ticket?

Follow the directions for each section. Each exercise will give you a number-letter pair. Write the letter in the matching numbered box at the bottom of the page.

I. Find each pair of congruent figures. Use the number from one figure and the letter from the other.

II. Complete each statement, then find your answer in the answer column. Use the number of the exercise and the letter of the answer.

$AABC \cong AEDF$

6 $\overline{AB} \cong \overline{DE}$ 9 $\angle A \cong \angle E$
 7 $\overline{BC} \cong \overline{DF}$ 10 $\angle B \cong \angle D$
 8 $\overline{AC} \cong \overline{EF}$ 11 $\angle C \cong \angle F$

Answers 6 - 11:
 (E) $\angle D$ (H) $\angle F$
 (S) \overline{EF} (T) \overline{DF}
 (E) \overline{DE} (U) $\angle E$

$\triangle SKM \cong \triangle ANG$

12 $\overline{SK} \cong \overline{GN}$ 15 $\angle S \cong \angle N$
 13 $\overline{KM} \cong \overline{JG}$ 16 $\angle K \cong \angle G$
 14 $\overline{SM} \cong \overline{NJ}$ 17 $\angle M \cong \angle J$

Answers 12 - 17:
 (S) $\angle J$ (A) \overline{GN}
 (E) \overline{JG} (R) $\angle N$
 (T) \overline{NJ} (C) $\angle G$

$\triangle RHX \cong \triangle TYL$

18 $\overline{TY} \cong \overline{RH}$ 21 $\angle T \cong \angle R$
 19 $\overline{YL} \cong \overline{HX}$ 22 $\angle Y \cong \angle H$
 20 $\overline{TL} \cong \overline{RX}$ 23 $\angle L \cong \angle X$

Answers 18 - 23:
 (R) $\angle R$ (K) \overline{RX}
 (E) \overline{RH} (T) $\angle H$
 (O) $\angle X$ (L) \overline{HX}

7 11 2 22 4 16 20 10 14 8 1 18 15 6 12 3 19 17 23 9 5 21 13
 T H E T I C K E T S W E R E A L L S Q U A R E

D-41

TOPIC 3-n Congruent Polygons

NOTE: This puzzle deals only with the congruence of angles in similar triangles. The proportionality of sides in similar figures is the topic of page E-12.

Does Any Animal Have More Than 9 Lives?

Give the angle measures indicated. Find each answer in the Code Key and notice the letter next to it. Write this letter in the box containing the number of the exercise.



$AABC \sim ADEF$ $AJKL \sim ARST$

1. $m\angle B = 60^\circ$ 3. $m\angle D = 50^\circ$ 5. $m\angle J = 41^\circ$ 7. $m\angle S = 90^\circ$
 2. $m\angle E = 60^\circ$ 4. $m\angle F = 70^\circ$ 6. $m\angle T = 49^\circ$ 8. $m\angle R = 41^\circ$

$AXYZ \sim AHPV$ $\triangle QGW \sim \triangle NMU$

9. $m\angle Z = 38^\circ$ 11. $m\angle V = 38^\circ$ 13. $m\angle Q = 50^\circ$ 15. $m\angle U = 84^\circ$
 10. $m\angle H = 67^\circ$ 12. $m\angle P = 75^\circ$ 14. $m\angle M = 46^\circ$ 16. $m\angle N = 50^\circ$

$AIEFG \sim \triangle HIG$ $\triangle ATL \sim \triangle OKC$

17. $m\angle IGH = 109^\circ$ 19. $m\angle F = 24^\circ$ 21. $m\angle T = 75^\circ$ 23. $m\angle OKC = 73^\circ$
 18. $m\angle H = 47^\circ$ 20. $m\angle E = 47^\circ$ 22. $m\angle KOC = 75^\circ$

11 13 2 23 12 8 20 1 19 22 5 10 17 16 14 3 21 9 15 7 18 4 6
 Y E S , F R O G S C R O A K E V E R Y N I G H T

D-42

TOPIC 3-o Similar Triangles

What Did the Waitress Mean When She Yelled to the Cook: "1 + 1"?

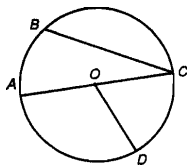

Fill in each blank with one of the answers at the bottom of the page. Then write the letter of the exercise above its correct answer.

The figure at the right is a circle with center O.

- (E) The points on a circle are all the same distance from the center.
- (S) A line segment from the center to any point on the circle is a radius.
- (C) A line segment with both endpoints on the circle is a chord.
- (I) A chord that passes through the center of a circle is a diameter.
- (O) A diameter of the circle in the drawing above is the segment AC.
- (E) Which of the following is not a radius: \overline{OA} , \overline{OD} , or \overline{BC} ? BC
- (S) Which of the following is not a chord: \overline{BC} , \overline{OA} , or \overline{AC} ? OA
- (N) Part of a circle, such as between points B and C, is an arc.
- (E) An angle whose vertex is at the center of a circle is a central angle.
- (P) Which of the following is not a central angle: $\angle AOD$, $\angle COD$, or $\angle BCA$? BCA
- (S) Points A, B, C, and D are all the same distance from point O.
- (O) If the length of \overline{AC} is 20 cm, then the length of \overline{OC} is 10 cm.
- (N) If the length of \overline{OA} is 20 cm, then the length of \overline{OD} is 20 cm.
- (V) If the length of \overline{OD} is 20 cm, then the length of \overline{AC} is 40 cm.
- (L) The length of a radius is half the length of a diameter.
- (T) The set of points in a plane at a fixed distance from a given point is a circle.

O	N	E	P	F	C	S	O	N	E	I	S	S	T	E	W		
10 cm	arc	center	ray	half	chord	OA	∠COD	AC	20 cm	central angle	OD	distance	80 cm	radius	circle	BC	40 cm

D-43

TOPIC 3-p Circles

What Did the Secretary Say to Her Boy Friend?

For each exercise, circle the letter of each figure that is divided by a line of symmetry. Arrange these letters to form a word. Then write this word on the line next to the exercisenumber.

1. YOU

2. ARE

3. JUST

4. MY

5. TYPE

TOPIC 3-q Lines of Symmetry

D-44

NOTE: Encourage students to write the name of each figure under it. You may want to have students make a table giving the number of faces, vertices, and edges of each polyhedron.

What Did the Taxi Driver Say About His Daughter?

Write the name that best describes each space figure. Then find your answer in the answer column. Write the letter of the answer in the box containing the number of the exercise.

10	1	12	8	3							
Y	O	U	A	U	T	O	M	E	T	E	R

1. sphere

2. cylinder

3. cone

4. cube

5. triangular prism

6. rectangular prism

7. pentagonal prism

8. hexagonal prism

9. triangular pyramid

10. rectangular pyramid

11. pentagonal pyramid

12. hexagonal pyramid

D-45

TOPIC 3-r Space Figures

Why Did the River Guide Carry a Rifle?

Find the PERIMETER of each figure. Cross out the box containing each correct answer. When you finish, write the letters from the remaining boxes in the spaces at the bottom of the page.

1. 13 cm, 10 cm, 16 cm. 41 cm

2. 14 ft, 9 ft, 14 ft. 37 ft

3. 3.5 m, 4 m, 5 m, 8.5 m. m

4. 2.0 km, 2.9 km, 2.5 km. 11.4 Km

5. 0.9 m, 1.8 m, 0.9 m. 7.2 m

6. 24 in., 24 in., 24 in., 24 in., 24 in., 24 in. 144 in.

7. 60 cm, 40 cm. 200 cm

8. 12.5 ft, 5 ft. 35 ft

9. 15 m, 8.2 m. 46.4 m

10. $l = 48$ mm, $w = 32$ mm. 160 mm

11. $l = 6.2$ km, $w = 4.7$ km. 21.8 Km

12. $l = 12$ in., $w = 12$ in. 48 in.

13. Find the perimeter of a sheet of typing paper $8\frac{1}{2}$ in. wide and 11 in. long. 39 in.

14. How many feet of border are needed to go around a square bulletin board that is 4.5 ft on each side? 18 ft

HE	TO	ST	SH	OT	OP	FL	OO	LS	OA	TT
48.9	43.4 m	14	18.6 km	1	2	48	156 in.	3	160	32 ft
HE	AT	RA	IN	TO	SC	PI	RE	NG	DS	ET
180 cm	38 ft	184 mm	21.9 cm	7.2 m	41	42 in.	200 mm	39	156 in.	11

T O S H O O T T H E R A P I D S

To SHOOT THE RAPIDS

TOPIC 4-a: Perimeter

D-46

NOTE: You might want to have students draw and label a diagram for each exercise.

What Is the Title?

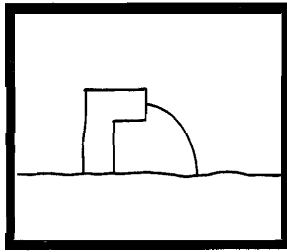

TO FIND THE TITLE OF THIS PICTURE:

Do each exercise below and find your answer in the code. Each time the answer appears, write the letter of the exercise above it.

CODED TITLE:

S A I L O R F I S H I N G
 21 6.3 15.75 42 16.6 70 215 15 15.75 21 16.5 15.75 96 65.6 19
 F B O M A S U B M A R I N E
 15 70 16.6 90 17.25 6.3 64 21 200 100 90 6.3 70 15.75 96 230

I. Find the perimeter of each figure.

- (C) Triangle with sides of 8.2 cm, 3.9 cm, and 4.5 cm **16.6 cm**
- (G) Square with sides of 16.4 m **65.6 m**
- E Parallelogram with sides of 40 cm and 75 cm **230 cm**
- (A) Regular decagon with sides of 0.63 km **6.3 km**
- B Rectangle with sides of 22 in. and 28 in. **100 in.**
- (I) Equilateral triangle with sides of 5.25 ft **15.75 ft**
- H Regular hexagon with sides of 2.75 in. **16.5 in.**
- (U) Rhombus with sides of 50 ft **200 ft**

II. Solve.

- (L) The width of a large American flag is 8 ft. Its height is 5 ft more than its width. Find its perimeter. **42 ft**
- (M) The perimeter of a square window is 360 cm. Find the length of one side. **90 cm**
- (R) A pennant is shaped like an isosceles triangle. The short side is 14 in. long and is half the length of each longer side. Find the perimeter of the pennant. **70 in.**
- (N) The width of a rectangular poster is 16 in. Its length is twice its width. Find its perimeter. **64 in.**
- (F) The perimeter of a triangle is 38 ft. One side is 14 ft long. Another side is 9 ft long. How long is the third side? **15 ft**
- (S) The longest side of a triangular sail is 9 m long. The second side is 1.5 m shorter than the longest side. The third side is half the length of the longest side. What is the perimeter? **21 m**

D-47

TOPIC 4-a Perimeter

Why Did the Piano Player Bang Her Head Against the Keyboard?

Find the circumference (C) of each circle, given the diameter (d) or radius (r). Use 3.14 for π. Draw a straight line connecting the square by the exercise to the square by its answer. The line will cross a number and a letter. Write the letter in the matching numbered box at the bottom of the page.

① d = 3 cm	⊗	C = 125.6 in.
② d = 8 in.	⊗	C = 31.4 cm
③ d = 7 cm	⊗	C = 94.2 in.
④ d = 40 in.	⊗	C = 9.42 cm
⑤ d = 9.2 cm	⊗	C = 72.22 in.
⑥ d = 1.5 in.	⊗	C = 301.44 in.
⑦ d = 600 m	⊗	C = 25.12 in.
⑧ d = 23 in.	⊗	C = 15.7 in.
⑨ d = 10 cm	⊗	C = 28.888 cm
⑩ r = 1 in	⊗	C = 13.816 cm
⑪ r = 6 cm	⊗	C = 15.7 cm
⑫ r = 15 in.	⊗	C = 21.98 cm
⑬ r = 2.2 cm	⊗	C = 6.28 in.
⑭ r = 48 in.	⊗	C = 314 m
⑮ r = 3.9 cm	⊗	C = 4.71 in.
⑯ r = 2.5 in.	⊗	C = 37.68 cm
⑰ r = 2.5 cm	⊗	C = 24.492 cm
⑱ r = 50 m	⊗	C = 1,884 m

1 2 3 4 5 6 7 8 9 10 11 12 13 14 15 16 17 18
S H E W A S P L A Y I N G B Y E A R

SHE WAS PLAYING BY EAR

TOPIC 4b Circumference

D-48

Answers J - R:

5 1/2 in.	FRESH	HE	EARTH	ON	WANTED	BECAUSE	ON	THE	JUMPED	PEAS	TOP	GROUND
22 in.												
37.68 ft												
88 in.												
34.5 ft	SUBMARINE											
660 mm												
132 mm												
84.78 in.												
154 mm												
720 mm												
4 1/2 in.												
143 mm												
33 ft												

Did You Hear About...?

A THE BOX BECAUSE	B SILLY GUY	C GUY	D WHO DUMPED	E DUMPED	F A
G BOX	H OF VEGETABLES	I ON THE GROUND	J ON THE GROUND	K THE GROUND	L GROUND
M BECAUSE HE WANTED PEAS	N HE WANTED PEAS	O ON THE GROUND	P ON THE GROUND	Q ON THE GROUND	R EARTH?

Find each answer in the appropriate answer column and notice the word under it. Write this word in the box containing the letter of the exercise.

- I. Find the circumference of each circle. Use 3.14 for π.
- (A) 4 cm **12.56 cm**
 - (B) 90 m **282.6 m**
 - (C) 3 ft **18.84 ft**
 - (D) 2.1 m **13.188 m**
 - (E) d = 20 ft **62.8 ft**
 - (F) d = 3.8 cm **11.932 cm**
 - (G) r = 250 m **1,570 m**
 - (H) r = 5 cm **31.4 cm**
- II. Find the circumference of each circle. Use 22/7 for π.
- (I) d = 14 ft **44 ft**
 - (J) d = 28 in. **88 in.**
 - (K) d = 49 mm **154 mm**
 - (L) d = 10 1/2 ft **33 ft**
 - (M) r = 21 mm **132 mm**
 - (N) r = 3 1/2 in. **11 in.**
 - (O) r = 105 mm **660 mm**
 - (P) r = 2 in. **4 1/2 in.**
- III. Solve. Use 3.14 for π.
- (Q) The wheels on a bicycle have a diameter of 27 in. How far does the bicycle travel with each turn of the wheels? **84.78 in.**
 - (R) The minute hand of a large clock is 6 ft long. How far does the tip of the hand move in one hour? **37.68 ft**

Answers A - I:

18.84 ft	GUY	HELPED	BOX	51 ft	HAMBURGER	11,932 cm	A	12.56 cm	THE	44 ft	VEGETABLES	13,188 m	WHO	1,630 m	BIG	282.6 m	SILLY	88.4 cm	OF	62.8 ft	DUMPED	11,542 cm	OFF
----------	-----	--------	-----	-------	-----------	-----------	---	----------	-----	-------	------------	----------	-----	---------	-----	---------	-------	---------	----	---------	--------	-----------	-----

D-49

TOPIC 4b Circumference

What Does a Tuba Call Its Father?

Give the number of square units in each figure. Find your answer and cross out the letters above it. When you finish, the answer to the title question will remain.

① 12	② 14	③ 32
④ 18	⑤ 46	⑥ 24
⑦ 15	⑧ 16	⑨ 20
⑩ 10	⑪ 44	⑫ 30
⑬ 9	⑭ 45	⑮ 28

32 15 9 42 20 12 28 21 44 18 8 PA 45 24 14 16 27 30 46 10

OOOM PAPA
 D-50

TOPIC 4-c Area of Rectangles

NOTE: Students need metric rulers for this puzzle.

What Did the Baseball Coach Look For in Space?

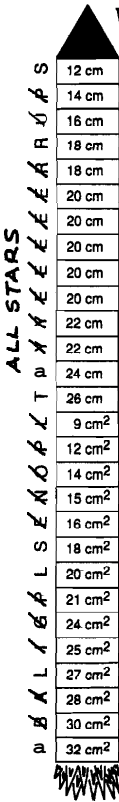

Measure the length and width of each rectangle to the nearest cm. Then compute both the PERIMETER and AREA. Find both answers in the rocket and cross out the letter next to each. (For answers that appear more than once in the rocket, it doesn't matter which one you cross out.)

When you finish, the answer to the title question will remain.

1. 2. 3. 4. 5. 6. 7. 8. 9. 10.

D-51 TOPIC 4-c: Area of Rectangles

Why Do Elephants Have Ivory Tusks?

Do each exercise and find your answer in the answer columns. Write the letter of the answer in each box containing the number of the exercise.

I. Find the area of each figure.

① ② ③ ④ ⑤ ⑥ ⑦ ⑧ ⑨

II. Find the area of the shaded region in each figure.

⑦ ⑧ ⑨

III. Solve.

⑩ A bedroom is 15 ft long and 12 ft wide. How much will it cost to carpet the room if carpeting costs \$22 per square yard? (1 yd = 3 ft) **\$ 440**

⑪ A rose garden in the city park is rectangular and is 9 m wide. If the area of the rectangle is 144 m², what is the length of the garden? **16 m**

..... ANSWERS
 (A) 219 ft² (T) 68 in.² (U) 251 ft² (G) 124 cm² (C) 21 m² (N) \$440
 (L) 20 m² (F) \$520 (V) 108 in.² (E) 24 m² (D) 88 ft² (P) 19 m
 (I) 135 cm² (S) 171 ft² (R) 16 m (B) 165 ft² (W) 119 in.² (O) 18 m²

I R O N O N E S W O U L D R U S T
 I R O N O N E S W O U L D R U S T

TOPIC 4-c: Area of Rectangles D-52

How Was the Wooden Marionette Related to the Wooden Diving Board?

Use a calculator to solve each problem (round decimal answers to the nearest tenth). Find your answer in the answer column and notice the two letters next to it. Write these letters in the spaces over the exercise number at the bottom of the page.

WORLD RECORD: The largest jigsaw puzzle ever made was 85 by 55 R and had 15,520 pieces. It was constructed by the United Way in Keene, New Hampshire.

- What was the area of the puzzle in ft²? **4,675 ft²**
- What was the area of the puzzle in in.²? **673,200 in.²**
- What was the average size of each piece? **43.4 in.²**

WORLD RECORD: The world's largest quilt, designed by A. Platteau, measures 69.6 by 99.5 R. It was made from 16,140 equal-sized squares sewn together.

- What is the area of the quilt in ft²? **6,925.2 ft²**
- What is the area of the quilt in in.²? **997,228.8 in.²**
- What is the area of each square? **61.8 in.²**

WORLD RECORD: The world's longest buffet table was 3,304.8 ft long and 8.2 ft wide. On June 19, 1982, approximately 4,000 people, including HM The King of Sweden, were seated at the table.

- What was the area of the table? **27,099.4 ft²**
- What was the perimeter of the table? **6,626 ft**
- If 4,000 people were equally spaced around the perimeter of the table, how far apart were they sitting? **1.7 ft**

WORLD RECORD: The largest American flag ever made was first displayed on March 22, 1960, and measures 411 by 210 ft.

- What is the area of the flag in ft²? **86,310 ft²**
- What is the area of the flag in yd²? **9,590 yd²**
- The fabric used for the flag weighs about 1.6 lb per yd². About how much does the flag weigh? **15,344 lb**

T H E Y H A D T H E S A M E F A M I L Y T R E E
 3 7 9 1 5 10 4 8 1 1 2 12 6
T H E Y H A D T H E S A M E F A M I L Y T R E E

D-53 TOPIC 4-d: Using a Calculator Perimeter and Area

What Happened to Mr. Meter When Mrs. Meter's Mother Flew in for a Visit?

Cross out the box containing each correct answer. When you finish, write the letters from the remaining boxes in the spaces at the bottom of the page.

I. Find the PERIMETER and the AREA of each parallelogram.

① ② ③ ④ ⑤ ⑥

II. Solve.

⑦ The base of a parallelogram is 10 in. The height is 2 in. more than half the base. Find the area. **70 in.²**

⑧ The height of a parallelogram is 4.5 cm. The base is twice the height. What is the area? **40.5 cm²**

⑨ The area of a parallelogram is 60 sq ft. The height is 5 ft. How long is the base? **12 ft**

⑩ The area of a parallelogram is 375 cm². The base is 25 cm. Find the height. **15 cm**

T	GH	HE	RE	E	WE	WA	IT
91.6 cm	17.4 cm	33.8 cm	15 cm	22 in.²	36 m	1.38 m²	70 in.²
SC	A	NT	EN	DA	RE	AL	T
37.6 cm²	180 m²	12 ft	18 m	380 ft	1.26 m²	16.32 cm²	16 ft
PR	IM	V	ET	TY	IS	ER	IT
5.4 m	350 ft	39.06 cm²	84 in.²	99.5 cm²	26 in.	6.3 m	8,100 ft²

H E W A S C E N T I M E T E R
H E W A S C E N T I M E T E R

TOPIC 4-e: Area of Parallelograms D-54

Tom Swift Said It This Way, Supposedly



- Answers
- (R) 100.1 cm²
 - (L) 24 in.²
 - (S) 10.5 ft²
 - (G) 810 ft²
 - (U) 96.5 cm²
 - (I) 20 in.²
 - (A) 187.5 m²
 - (P) 70 cm²
 - (B) \$475
 - (D) 22.5 cm²
 - (N) 32 in.²
 - (C) 72 m²
 - (F) 790 ft²
 - (E) 68 cm²
 - (X) 3.15 km²
 - (H) 172.5 m²
 - (O) 7.5 in.²
 - (L) \$450
 - (Y) 144 mm²
 - (K) 8.25 in.²
 - (M) 3.4 km²

1. "I hate playing tic-tac-toe," Tom said.
 2. "I wish I were six feet tall," Tom said.
 3. "I just flew in from the coast," Tom said.

Find the area of each triangle, then find your answer in the answer column. Write the letter of the answer in each box containing the number of the exercise.

C R O S S L Y
L O N G I N G L Y
E X P L A I N E D

① 20 in.² ② 72 m² ③ 70 cm² ④ 144 mm² ⑤ 18 mm ⑥ 7.5 in.²
 ⑦ 10.5 ft² ⑧ 22.5 cm² ⑨ 100.1 cm² ⑩ 3.15 km² ⑪ 10.5 ft² ⑫ 810 ft²
 ⑬ 107.5 m² ⑭ 3.4 km²

⑭ A square dinner napkin 8 in. on each side is folded along its diagonal. Find the area of the folded napkin. **32 in.²**

⑮ A triangular sail has a base of 5 m and a height of 10 m. If canvas costs \$9 to a square meter, find the cost of canvas to make the sail. **\$450**

D-55 TOPIC 41 Area of Triangles

What Happens When the Smog Lifts in Los Angeles, California?

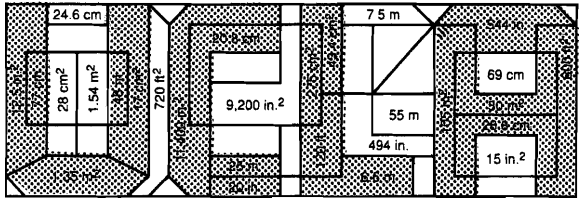

Find the AREA and the PERIMETER of each triangle below. Look for both answers in the rectangle. Shade in each area containing a correct answer.

① 12.5 in. 9 in. 6 in. 5 in. **30 m² 3**
 ② 30 cm 25 cm 30 cm 22 cm 5 m² **28.8 cm 43.4 m²**
 ③ 17 cm 12.4 cm 8.2 cm
 ④ 4.6 cm 4 cm 8.5 cm
 ⑤ 3 m 1.5 m **544 in. 11,400 in.²**
 ⑥ 40 ft 30 ft 50 ft **120 ft 600 ft²**
 ⑦ 20.8 cm 17 cm² ⑧ 6.6 m 1.35 m² ⑨ 114 in. 230 in. 200 in. **11,400 in.²**

TOPIC 41 Area of Triangles D56

NOTE: Units of measurement were omitted in the answer columns. Students are asked to fill in the correct unit for each answer chosen. In this way, they should become more aware of the units involved.

Perimeters	Areas
95	58 cm ² 3-L
24 in.	34
67	300 cm ² 6-S
10.1 m	60 m ² 21-H
46 cm	136
152	3.08 m ² 29-S
100 cm	64
38 cm	24 in. ² 26-O
32 m	144 in. ² 27-R
40 m	3.26
9.4	130 cm ² 28-D
51 cm	1,500
74 cm	203 in. ² 11-A
34	48 m ² 9-D
48 in.	240
166 ft	48 in. ² 7-S
49	616 cm ² 19-O
80 in.	120 cm ² 23-R
22	576
23	7-H

Why Was Igor Unhappy About His Spelling Test Even Though He Got Everything Right?

Give both the perimeter and area of each figure. Find each answer in the appropriate answer column. Fill in the correct unit of measure for each answer you choose, then circle the number-letter next to it. Write the letter in the matching numbered box at the bottom of the page.

① 46 cm 130 cm² ② 74 cm 300 cm² ③ 32 m 48 m²
 ④ 24 in. 24 in.² ⑤ 51 cm 120 cm² ⑥ 166 ft 15,500 ft²
 ⑦ 38 cm 58 cm² ⑧ 10.1 m 4.7 m² ⑨ 19 in. 80 in.²
 ⑩ 100 cm 616 cm² ⑪ 48 in. 144 in.² ⑫ 22 cm 28 cm²

H E M I S E D A L L T H E M O R D S

D-57 TOPIC 4-g Perimeter and Area of Rectangles, Parallelograms, and Triangles

What Game Did Tarzan Like to Play?

Do each exercise below. Find your answer in the answer columns and notice the letter next to it. Look for this letter in the string of letters near the bottom of the page and CROSS IT OUT each time it appears. When you finish, write the remaining letters in the rectangle at the bottom of the page.

I. Find the area of each trapezoid.

① 30 cm² ② 75 in.² ③ 1,400 m² 20 m
 ④ 3.68 cm² ⑤ 77 ft² ⑥ 5.6 m²
 ⑦ b₁ = 11 in. b₂ = 9 in. h = 8 in. **80 in.²** ⑧ b₁ = 3.4 m b₂ = 6.4 m h = 5.0 m **24.5 m²** ⑨ b₁ = 70 cm b₂ = 30 cm h = 25 cm **2,500 cm²**

II. An artist designed a base for one of his sculptures with the dimensions shown. The top and bottom are rectangles. The sides are isosceles trapezoids.

⑩ Find the area of the front face (20 cm base). **105 cm²**
 ⑪ Find the area of the side face (12 cm base). **60 cm²**
 ⑫ Find the area of the top. **120 cm²**

Y 76 in. ²	N 105 cm ²	O 80 in. ²	D 3.68 cm ²	S 3.92 cm ²
L 24.5 m ²	B 30 cm ²	T 120 cm ²	Z 1,360 cm ²	F 5.6 m ²
A 72 cm ²	H 69 ft ²	P 26.2 m ²	M 75 in. ²	I 80 cm ²
U 1,400 m ²	C 95 cm ²	G 77 ft ²	H 1,250 cm ²	E 4.5 m ²

Answer to puzzle: **CRAZY APES**

TOPIC 4h Area of Trapezoids D-58

What Is Dangerous about Living for 7 Days on just One Can of Sardines?

Find the area of each circle. Use 3.14 for π . Find your answer in the appropriate answer column. Write the letter of the answer in the space containing the number of the exercise. If the answer has a \bullet shade in the space instead of writing a letter in it.

Answers 1 – 9:

- 1 P 214.14 ft²
- 2 A 54.84 in.²
- 3 U 19,625 cm²
- 4 B 361.14 m²
- 5 L 28.26 cm²
- 6 G 7,850 in.²
- 7 L 314 m²
- 8 S 5,1016 km²
- 9 E 254.34 ft²

Answers 10 – 18:

- 10 P 1,416 m²
- 11 D 78.5 cm²
- 12 O 36,815 cm²
- 13 H 7,065 m²
- 14 H 0,2826 km²
- 15 N 108,74 in.²
- 16 M 1,256 m²
- 17 L 153,86 in.²
- 18 S 211.36 ft²
- 19 L 39,465 cm²
- 20 F 3.14 cm²
- 21 Y 200.96 ft²
- 22 C 0.3416 km²
- 23 R 8,415 m²
- 24 F 113.04 in.²

1 28.26 cm^2 **2** 50.24 in.^2 **3** 314 m^2

4 12.56 cm^2 **5** $r=9 \text{ ft}$ 254.34 ft^2 **6** $r=1.2 \text{ km}$ $4,521.6 \text{ km}^2$

7 $7,850 \text{ in.}^2$ **8** $r=11 \text{ m}$ 379.94 m^2 **9** $r=2.5 \text{ cm}$ 19.625 cm^2

10 153.86 in.^2 **11** 78.5 cm^2 **12** 7.065 m^2

13 $d=16 \text{ ft}$ 200.96 ft^2 **14** $d=40 \text{ m}$ $1,256 \text{ m}^2$ **15** $d=12 \text{ in.}$ 113.04 in.^2

16 $d=7 \text{ cm}$ 36.465 cm^2 **17** $d=0.6 \text{ km}$ 0.2826 km^2 **18** $d=2 \text{ cm}$ 3.14 cm^2

13 2 9 4 14 1 7 10 12 18 6 3 16 8 11 15 5
Y O U M I G H T F A L L O F E

D-59

TOPIC 4-1 Review Circumference and Area of Circles

NOTE: Units of measurement were omitted in the answer columns. Students are asked to fill in the correct unit for each answer chosen. In this way, they should become more aware of the units involved.

Why Is a Mathematician Like an Airline?

Round each answer to the nearest hundredth (if necessary) and find it in the appropriate answer column. Use 3.14 for π . Fill in the correct unit of measure for each answer you choose. Write the letter of the exercise in the box containing the number of the answer.

1. A circle has a radius of 12 in. Find:
 - (E) The diameter of the circle. **24 in.**
 - (H) The circumference of the circle. **75.36 in.**
 - (T) The area of the circle. **452.16 in.²**
2. A circle has a radius of 4.4 cm. Find
 - (S) The diameter of the circle. **8.8**
 - (Y) The circumference of the circle. **27.63 cm**
 - (H) The area of the circle. **60.79 cm²**
3. A circle has a diameter of 60 m. Find:
 - (I) The radius of the circle. **30 m**
 - (O) The circumference of the circle. **188.4 m**
 - (T) The area of the circle. **2,826 m²**
4. A circle has a diameter of 1.8 km. Find.
 - (O) The radius of the circle. **0.9 km**
 - (E) The circumference of the circle. **5.65 km**
 - (U) The area of the circle. **2.54 km**

Answers 1 – 3:	Answers 4 – 5:
4 27.63 cm	15
14 61.43	6 706.5 ft ²
16 30 m	13 5.174
2 75.36 in.	9 24.930
12 461.36	11 2.54 km
21 8.8 cm	20 0.79 m ²
17 172.4	19 0.9 km
13 24 in.	18 942 ft
9 60.79 cm ²	10 690.5
1 2.826 m ²	14 2.91
8 452.16 in. ²	15 5.024 mi
5 25.51	3 5.65 km
7 188.4 m	17 0.87
10 2.516	12 25.120 mi

5. Solve.
 - (B) Jack's cow is tied to a beanstalk with a piece of rope that is 15 ft long. What is the area of the circle in which the cow can graze? **706.5 ft²**
 - (T) A round game table has a diameter of 1 m. How much plastic laminate is needed to cover the top of this table? **0.79 m²**
 - (S) The diameter of the earth at the equator is about 8,000 mi. Based on this figure, how far is it around the earth? **25,120 mi**
 - (P) Radio station KROQ broadcasts in all directions to a distance of 40 mi. How many square miles are in the station's broadcast area? **5,024 mi.²**
 - (L) WORLD RECORD: The world's largest Ferris Wheel was built in London in 1897. The wheel had a radius of 150 ft. How far would you travel in one turn of this wheel? **942 ft**

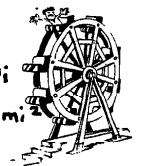

1 2 3 4 5 6 7 8 9 10 11 12 13 14 15 16 17 18 19 20 21
T H E Y B O T H U S E P I L O T S

D-61 TOPIC 4-1 Review Circumference and Area of Circles

What Is the Title of This Picture?

TOPIC 4-1 Review Circumference and Area of Circles

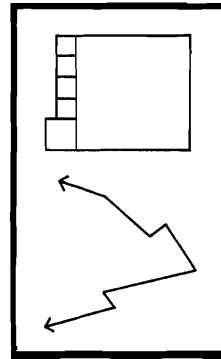

Use the diameter (d) or radius (r) of each circle to find the circumference (C) and area (A) of the circle. Use 3.14 for π . Round answers to the nearest hundredth (if necessary). Each time an answer appears in the coded title, write the letter of the exercise above it.

CODED TITLE:

W R E C K E D A G L E W L T H
5,024 176.63 0.7 40 1.017,36 0.7 5.2 4,954 18.84 3 113.04 0.7 1.69 5,024 28.26 4.40 21.23
O N E S Q U A R E F O O T
16.33 47.1 0.7 172.38 36 1.54 251.2 18.84 176.63 0.7 984.46 15 16.33 16.33 4.40

1

C $r=2 \text{ cm}$ $A=25.12 \text{ cm}^2$ **2** D $d=5.2 \text{ m}$ $A=21.23 \text{ m}^2$

U $C=251.2 \text{ in.}$ **3** C $r=40 \text{ ft}$ $A=5,024 \text{ ft}^2$

W $A=5,024 \text{ ft}^2$ **4** R $r=18 \text{ in.}$ $A=1017.36 \text{ in.}^2$

A $C=18.84 \text{ cm}$ **5** E $d=1.4 \text{ cm}$ $C=4.40 \text{ cm}$

L $A=1.54 \text{ cm}^2$ **6** R $r=7.5 \text{ mm}$ $C=47.1 \text{ mm}$

H $A=1.54 \text{ m}^2$ **7** F $d=15 \text{ mm}$ $A=176.63 \text{ mm}^2$

A $A=21.23 \text{ m}^2$ **8** F $d=15 \text{ mm}$ $A=176.63 \text{ mm}^2$

D-60

How Do You Get a One-Armed Monkey Down From a Coconut Tree?

Solve each problem. Use 3.14 for π . Find your answer and cross out the letter next to it. When you finish, the answer to the title question will remain.



WAVE AT HIM
Y X W I N B A X Y A Y B T H B F I Y M F
95 in.²
9.2 in.
706.5 cm²
8.3 m
8.4 in.
26 ft
1,670 ft²
131 in.²
30 ft
9.6 in.
127.2 cm²
2.5 cm
28 ft
69.5 in.²
21.5 in.²
154 in.²
814.5 cm²
7.8 m
593.5 cm²
59 in.²
30.5 in.²
78.5 in.²
1,960 ft²
113.0 cm²

1. Find the diameter of a circle if the circumference is 8 cm. Round to the nearest tenth. **2.5 cm**
2. Find the diameter of a circle if the circumference is 24.5 m. Round to the nearest tenth. **7.8**
3. The largest living thing on earth is a California sequoia tree named the "General Sherman." The circumference of its trunk is about 82 ft. Find the diameter of the trunk to the nearest whole number. **26 ft**
4. A revolving water sprinkler sprays water in all directions to a distance of 25 ft. What area does it cover? Round to the nearest 10 ft². **1,960 ft²**
5. Pizza Mind Pizza sells a large pizza with a diameter of 14 in. and a medium pizza with a diameter of 11 in. Find the following to the nearest whole number:
 - A. The area of the large pizza. **154 in.²**
 - B. The area of the medium pizza. **95 in.²**
 - C. How much larger is the large pizza? **59 in.²**
6. Nick Claus plans to have a model train running in a circle around his holiday tree. How many feet of track will he need if the diameter of the circle is 9.5 ft? Round to the nearest whole number. **30 ft**
7. A record has a radius of 15 cm. The label has a radius of 6 cm. Find the following to the nearest tenth:
 - A. The area of the record. **706.5 cm²**
 - B. The area of the label. **113.0 cm²**
 - C. The area of the record that is not covered by the label. **593.5 cm²**
8. The diameter of a basketball hoop is 18 in. The circumference of a basketball is 30 in.
 - A. Find the diameter of the basketball. Round to the nearest tenth. **9.6 in.**
 - B. How much less is the diameter of the basketball than the diameter of the hoop? **8.4 in.**
9. A circle is cut out of a piece of plywood that is 10 in. square. The scraps are thrown away.
 - A. Find the area of the circle. **78.5 in.²**
 - B. How many square inches of plywood are thrown away? **21.5 in.²**

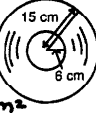

TOPIC 4-1 Problem Solving: Mixed Applications D-62

When Is a Chair Like the Fabric Used to Make It?

Write the correct formula to use in solving each problem. Find your answer in the Code Key and notice the letter next to it. Write this letter in the box containing the number of the problem.

WHEN IT'S SATIN (SATIN)
 4 9 7 5 3 10 1 12 6 2 8 11
 W H E N I T S A T I N

Code Key	Perimeter/ Circumference	Area
(S)	$P = \text{sum of the lengths of the sides.}$	$A = \frac{1}{2}bh$
(A)	$P = 2(A, 2w)$	$A = \frac{1}{2}bh$
(W)	$P = 4s$	$A = \pi r^2$
(L)	$C = \pi d$ or $C = 2\pi r$	$A = \pi r^2$
(T)	$A = lw$	$A = \pi r^2$
(E)	$A = s^2$	$A = \frac{1}{2}bh$
(H)	$A = \frac{1}{2}bh$	$A = \pi r^2$
(N)	$A = \pi r^2$	$A = \pi r^2$

- 1 A botanical garden was designed in the shape of a pentagon. How many meters of fencing are needed to go around the garden?
 $P = \text{sum of the sides}$
- 2 How many square feet of wallpaper are needed to cover a wall 8 ft high by 15 ft wide?
 $A = lw$
- 3 The diameter of a circular running track is 140 yd. How far would you run in one lap?
 $C = \pi d$
- 4 How much weather stripping is needed to go around a square window measuring 42 in. on a side?
 $P = 4s$
- 5 A dangerous criminal has escaped from prison. The police believe he could have traveled more than 10 mi in any direction from the prison. How many square miles must be searched?
 $A = \pi r^2$
- 6 $\frac{1}{2}$ inch lace edging is needed to go around a rectangular tablecloth measuring n. by 70 in.?
 $P = 2L + 2W$
- 7 How many tiles are needed to cover a square patio measuring 18 ft on a side if each tile covers 1 sq ft?
 $A = S^2$
- 8 The orbit of the earth around the sun is approximately a circle with a radius of 93,000,000 mi. How far do we travel in one orbit around the sun?
 $C = 2\pi r$
- 9 How much left is needed to make this banner?
 $A = \frac{1}{2}bh$
- 10 If each bag of fertilizer covers 2,000 sq ft, how many bags are needed to fertilize a rectangular lawn measuring 100 ft by 160 ft?
 $A = lw$
- 11 A lighthouse beacon can be seen 24 mi in all directions. What is the area over which the beacon can be seen?
 $A = \pi r^2$
- 12 Popeye put colorful plastic tape around the edge of a triangular sail. The sail had sides of 10 ft, 15 ft, and 18 ft. How many feet of tape did he use?
 $P = \text{sum of the sides}$

D-63 TOPIC 4-I: Problem Solving: Choosing a Formula

What Happened to Zelda After She Swallowed Two Nickels, Three Dimes, and a Quarter?

Give the SURFACE AREA of each prism. Find your answer in the answer columns and notice the two letters next to it. Write these letters in the spaces over the exercise number at the bottom of the page.

- 1 94 cm^2
- 2 104 m^2
- 3 $9,600 \text{ in.}^2$
- 4 73 m^2
- 5 25.92 cm^2
- 6 300.56 m^2
- 7 A rectangular storage box is 12 in. wide, 15 in. long, and 9 in. high. How many square inches of colored paper are needed to cover the surface of the box?
 846 in.^2
- 8 A teacher made a pair of foam dice to use in math games. Each cube measured 10 in. on a side. How many square inches of fabric were needed to cover the two cubes?
 $1,200 \text{ in.}^2$

(TH)	73 m ²	Answers	(QB)	8,560 in. ²	
(AL)	23.12 cm ²	(AS)	94 cm ²	(NO)	25.92 cm ²
(EW)	846 in. ²	(IT)	86 m ²	(AN)	9,600 in. ²
(ER)	104 m ²	(CH)	1,200 in. ²	(GE)	300.56 m ²
				(TR)	85 cm ²

T H E R E W A S N O C H A N G E
 4 2 7 1 5 8 3 6

TOPIC 5-a: Surface Area of Rectangular Prisms D-64

What Is Cold And Comes In Cans?

Find the surface area of each figure. Cross out the box containing each coned answer. When you finish, write the letters from the remaining boxes in the spaces at the bottom of the page.

- 1 146 cm^2
- 2 406 in.^2
- 3 22.6 m^2
- 4 81.5 cm^2
- 5 $3,300 \text{ mm}^2$
- 6 145.92 cm^2
- 7 340 m^2
- 8 60.45 cm^2

MU	RI	CH	OW	OP	FO	IL
240 m ²	224 in. ²	3,120 mm ²	148 cm ²	30 in. ²	3,500 mm ²	118 in. ²
IB	AR	CL	EA	CA	NS	KE
81.5 cm ²	22.6 m ²	60.45 cm ²	312 m ²	145.92 cm ²	25.8 m ²	406 in. ²

CHILI BEANS

D-65 TOPIC 5-b: Surface Area of Prisms and Pyramids

Why Did Humpty Dumpty Have a Great Fall?

Do each exercise and find your answer in the answer column. Write the letter of the answer in each box containing the number of the exercise. Use 3.14 for π .

- I. Find the lateral area and the total surface area of each cylinder.
 - 1 lateral area: 376.8 cm^2
 - 2 total area: 533.8 cm^2
 - 3 lateral area: 251.2 ft^2
 - 4 total area: 351.68 ft^2
 - 5 lateral area: $8,792 \text{ cm}^2$
 - 6 total area: $11,304 \text{ cm}^2$
 - 7 lateral area: 367.36 m^2
 - 8 total area: 876.06 m^2
- II. Find the total surface area of each cylinder.
 - 9 $r = 3 \text{ cm}$, $h = 10 \text{ cm}$
 - 10 $r = 8 \text{ in.}$, $h = 8 \text{ in.}$
 - 11 $d = 10.8 \text{ m}$, $h = 2.6 \text{ m}$
- III. SOLVE.
 - 12 A can of tomato juice is a cylinder with a radius of 7.5 cm and a height of 20 cm. What is the area of the label around the can?
 942 cm^2
 - 13 A steel oil tank is a cylinder with a diameter of 12 ft and a height of 18 ft. How many square feet of steel were needed to make the tank?
 904.32 ft^2

T O M A K E U P F O R A B A D S U M M E R
 3 1 8 13 11 6 4 2 9 5 8 10 11 12 11 1 7 2 13 13 4 10

TO MAKE UP FOR A BAD SUMMER

TOPIC 5-c: Surface Area of Cylinders D-66

Mystery: What happened when a 6-year old, a 5-year old, a 4-year old, a 3-year old, and a 2-year old joined to form a basketball team?

Find the volume of each prism in cubic units. Write the letter of the exercise in the box containing the answer.

40 24 36 16 32 72 64 12 48 80 45 28 75 42 30 60 18
THEY WERE ONELESS

D-67 TOPIC 5-d: Volume of Rectangular Prisms

What Movie Is about a Kid Who Ran Away from Home with His Bicycle?

Find each answer in the answer columns and notice the two letters next to it. Write these letters in the spaces over the exercise number at the bottom of the page.

I. Find the volume of each rectangular prism.

1. 864 in.^3

2. 9.8 m^3

II. Solve.

4. A classroom is 26 ft wide, 32 ft long, and 9 ft high. What is the volume of the room in cubic feet? **7,488 ft³**

5. A swimming pool is 20.6 m long, 8.5 m wide, and has an average water depth of 1.7 m. Find the volume of water needed to fill the pool. **297.67 m³**

6. If all the gold that has been produced in the last 500 years could be melted to form a single cube, each side would measure about 16 m. How many cubic meters of gold is this? **4,096 m³**

7. A refrigerator is 3 ft wide, 2.5 ft deep and 6 ft high. The walls and other of the refrigerator take up 20 ft³. How many cubic feet are left for food? **25 ft³**

8. Krispy Kritters Cereal used to come in a box with a volume of 2,850 cm³. However, The Krispy Kritters Co. designed a new larger box 22.5 cm wide, 6.2 cm deep, and 30 cm high. How many more cubic centimeters will the new box hold than the old box? **1,335 cm³**

9. An aquarium weighs 22.5 lb when empty. The aquarium is 30 in. long, 14 in. wide, and is filled with water to a depth of 18 in. Water weighs 0.036 pound per cubic inch. How much does the aquarium weigh when it is full of water? **294.66 lb**

ANSWERS

(RU) 985 cm³ (ST) 6.118 ft³ (WI) 4.096 m³ (LA) 314.56 lb (TH) 864 in.³
 (NN) 297.67 m³ (CH) 53.352 cm³ (IN) 23.5 ft³ (GO) 1.335 cm³ (LE) 311.27 m³
 (WJ) 294.66 lb (ES) 25 ft³ (NE) 9.8 m³ (PA) 3.986 m³ (TH) 7.488 ft³

G O N E W I T H T H E S C H W I N N
 8 2 6 1 4 7 3 9 5
GONE WITH THE SCHWINN

TOPIC 5-g: Problem Solving Mixed Applications D-68

NOTE: You might want to compare the first 2 figures on the second line. The triangular prism is half the rectangular prism.

What Is Big, Gray, and Lives in California?

Find the volume of each prism. Write the letter of the exercise in the box above the answer at the bottom of the page.

A N L A P H A N T
 83.8 cm³ 357.12 cm³ 76.8 cm³ 8,800 in.³ 92.31 cm³ 84.71 cm³ 156.6 cm³ 114.5 in.³ 384.5 m³ 7,500 in.³ 127.5 in.³ 15,000 in.³ 380 m³ 160 m³ 349.22 cm³

D-69 TOPIC 5-f: Volume of Prisms

☆ TRIVIA TEST 4

1. What Is the Best Way to Paint a Rabbit? **W I T H H A R E S P R A Y**
 4 7 2 8 8 3 11 5 10 1 11 3 6
2. What Candy Do Kids Eat on the Playground? **R E C E S S I P L E S**
 11 5 9 5 10 10 1 7 5 9 5 10

Do each exercise and find your answer in the answer column. Write the letter of the answer above the exercise number each time it appears in the code. Use 3.14 for π .

I. Find the volume of each cylinder.

1. 675 cm^3

2. 15.4 m^3

3. 141.3 cm^3

4. $2,260.8 \text{ in.}^3$

5. $7,850 \text{ m}^3$

6. 846.23 cm^3

7. $r = 8 \text{ in.}$

8. $r = 2.5 \text{ mm}$

9. $d = 10 \text{ m}$

10. 376.8 cm^3

11. 452.16 mL

Answers

(M) 814.13 cm³
 (C) 565.2 m³
 (N) 381.36 mL
 (A) 141.3 cm³
 (B) 14.8 m³
 (I) 602.88 in.³
 (P) 675 cm³
 (H) 7,490 m³
 (U) 1,177.5 mm³
 (R) 452.16 mL
 (W) 2,260.8 in.³
 (L) 382.8 cm³
 (T) 15.4 m³
 (Y) 846.23 cm³
 (O) 717.8 in.³
 (S) 376.8 cm³
 (G) 1,224.5 mm³
 (E) 7,850 m³
 (D) 614.2 m³

TOPIC 5-g: Volume of Cylinders D-70

Why Did the Elephant Paint His Toenails Red, Green, Yellow, Blue, and Purple?

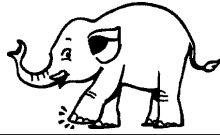

Find each answer in the appropriate set of boxes at the bottom of the page. Write the letter of the exercise in the box containing the answer.

I. Find the length of one side (s) of each square.

(O)
 (I)
 (E)

II. Find the square root.

(S) $\sqrt{49}$ 7 (L) $\sqrt{16}$ 4 (I) $\sqrt{100}$ 10 (O) $\sqrt{81}$ 9
 (E) $\sqrt{36}$ 6 (D) $\sqrt{4}$ 2 (H) $\sqrt{144}$ 12 (N) $\sqrt{1}$ 1
 (C) $\sqrt{900}$ 30 (U) $\sqrt{2,500}$ 50 (U) $\sqrt{6,400}$ 80

III. Simplify.

(E) 15^2 225 (H) 11^2 121 (A) 25^2 125
 (Y) $\sqrt{225}$ 15 (E) $\sqrt{121}$ 11 (L) $\sqrt{625}$ 25
 (A) $\sqrt{16} + \sqrt{9}$ 7 (E) $\sqrt{36} + \sqrt{64}$ 14 (R) $\sqrt{25} - \sqrt{9}$ 2
 (N) $\sqrt{16 \cdot 9}$ 5 (T) $\sqrt{36 \cdot 64}$ 10 (J) $\sqrt{25 \cdot 9}$ 4
 (L) $\sqrt{0.25}$ 0.5 (B) $\sqrt{0.81}$ 0.9 (J) $\sqrt{0.01}$ 0.1

Answers for Part I and Part II

S O H E C O U L D H I D E I N

Answers for Part III

T H E J E L L Y B E A N J A R

D-71

TOPIC 6-a: Squares and Square Roots

Why Did the Teacher Assign Extra Homework When She Taught Adolescents?



Find which two consecutive whole numbers the square root is between. Write the letter of the exercise on the number line between these two numbers.

Use the top number line for the first set of exercises, and the bottom number line for the rest.

(S) $\sqrt{30}$ 5, 6 (H) $\sqrt{2}$ 1, 2 6, 7
 (E) $\sqrt{8}$ 2, 3 (A) $\sqrt{23}$ 4, 5 (N) $\sqrt{120}$ 10, 11
 (G) $\sqrt{138}$ 11, 12 (I) $\sqrt{82}$ 9, 10 (W) $\sqrt{11}$ 3, 4
 8, 9 (S) $\sqrt{0.5}$ 0, 1 (R) $\sqrt{59}$ 7, 8

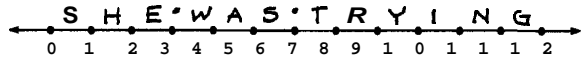

(S) $\sqrt{75}$ 8, 9 (D) $\sqrt{20}$ 4, 5 (O) $\sqrt{3}$ 1, 2
 (A) $\sqrt{6}$ 2, 3 7, 8 9, 10
 (C) $\sqrt{112}$ 10, 11 (N) $\sqrt{125}$ 11, 12 (D) $\sqrt{14}$ 3, 4
 (T) $\sqrt{0.1}$ 0, 1 (A) $\sqrt{33}$ 5, 6 (L) $\sqrt{40}$ 6, 7

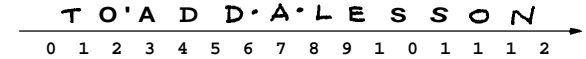

TOPIC 6-a: Squares and Square Roots

D-72

Why Do Adults Complain So Much?

Find the length of the hypotenuse of each right triangle below. Find your answer in the answer column. Write the letter of the answer in the box containing the number of the exercise.

(1)
 (2)
 (3)
 (4)
 (5)
 (6)
 (7)
 (8)
 (9)
 (10)
 (11)
 (12)
 (13)
 (14)
 (15)



Answers

- (E) $\sqrt{85} = 9.2$
- (Y) $\sqrt{169} = 13$
- (O) $\sqrt{130} = 11.4$
- (U) $\sqrt{289} = 17$
- (T) $\sqrt{225} = 15$
- (H) $\sqrt{800} = 28.3$
- (E) $\sqrt{25} = 5$
- (N) $\sqrt{580} = 24.1$
- (R) $\sqrt{2,500} = 50$
- (S) $\sqrt{346} = 18.6$
- (P) $\sqrt{89} = 9.4$
- (L) $\sqrt{275} = 16.6$
- (G) $\sqrt{65} = 8.1$
- (A) $\sqrt{200} = 14.1$
- (R) $\sqrt{289} = 16.4$
- (A) $\sqrt{100} = 10$

T H E Y A R E R O A D S

D-73

TOPIC 6-b: The Rule of Pythagoras. Finding the Length of the Hypotenuse

NOTE: Students will need calculators with a square root key or a table of square roots for this puzzle and the 2 that follow.

How Would You Describe a Dead Skunk?

Round each answer to the nearest tenth (if necessary). Find each answer at the bottom of the page and cross out the letter above it. When you finish, the answer to the title question will remain.

(1) Find the length of the hypotenuse of each right triangle.
 A
 B
 C
 (2) A rectangle is 6 m wide and 11 m long. How long is the diagonal of the rectangle? 12.5 m
 (3) A television screen may be described in terms of the diagonal measure of its screen. If a TV screen is 20 in. wide and 15 in. high, what is the length of its diagonal? 25 in.
 (4) A quarterback at point A throws the football to point B. How long was the pass? 26.7 yd
 (5) A rope is stretched from the top of a 7-foot tent pole to a point on the ground 12 ft from the base of the pole. How long is the rope? 13.9 ft
 (6) Kristin and her family left their campsite for a hike. They hiked 5 mi west and then 2 mi north. How far were they from the campsite? 5.4 mi
 (7) The window of a burning building is 40 feet above the ground. The base of a ladder is placed 9 feet from the building. How long must the ladder be to reach the window? 41 ft
 (8) The boards from the base of the tunnel extend to second base? 127.3 ft
 (9) The lawn in front of Pythagoras Jr. High is in the shape of a rectangle 24 m long and 10 m wide. How many meters shorter is your walk if you walk diagonally across the lawn rather than along two sides of it? 6

X E X X X X T X X I X N X X C X T X
 5.4 mi 29.3 yd 15.3 m 8 m 13.2 m 12.5 m 16.7 in. 41 ft 12.2 cm 6.1 mi 13.9 ft 42.5 ft 127.3 ft 28.7 yd 14.4 ft 17.0 in. 129.8 ft 25 in.

TOPIC 6-b: The Rule of Pythagoras. Finding the Length of the Hypotenuse

D-74

Cryptic Quiz

1. What is the opposite of a professional eater?

A N A M A C H E W E R
8.8 19.6 18.5 8.8 10.9 8.8 3.3 9.8 70.7 1.4 70.7 14.5

2. How would you describe a job in the Acme Mitten Co. shipping department?

B O X I N G G L O V E S
22.4 16.1 19.2 5 19.6 6 68 6 8 16.1 9.2 70.7 6.3

3. What can be right but never wrong?

A N A N G L E
8.8 19.6 7.4 8.8 19.6 6 8 70.7

For each exercise, find the missing length. (Refer to the diagram at the right.) Round your answer to the nearest tenth (if necessary) and find it in the code. Each time the answer appears, write the letter of the exercise above it.

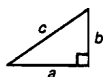

- (H) $a = 9, b = 4, c = 9.8$ (E) $a = 50, b = 50, c = 70.7$
 (C) $a = 8, b = 14, c = 16.1$ (B) $a = 22.4, b = 20, c = 30$
 (Q) $a = 6.3, b = 3, c = 7$ (V) $a = 6, b = 9.2, c = 11$
 (M) $a = 10.9, b = 5, c = 12$ (W) $a = 1, b = 1, c = 1.4$
 (G) $a = 6, b = 8, c = 10$ (X) $a = 19.2, b = 16, c = 25$
 (C) $a = 5, b = 3.3, c = 6$ (A) $a = 2, b = 8.8, c = 9$
 (R) $a = 4, b = 14.5, c = 15$ (L) $a = 8, b = 15, c = 17$
 (I) $a = 12, b = 5, c = 13$ (N) $a = 10, b = 19.6, c = 22$

D-75 TOPIC 6-c: The Rule of Pythagoras: Finding the Length of a Side of a Right Triangle

What Relation Is a Doorstep to a Doormat?

Round each answer to the nearest tenth (if necessary). Cross out the box containing each answer. When you finish, write the letters from the remaining boxes in the spaces at the bottom of the page.

1. For each right triangle, find the length of the side that is not given.

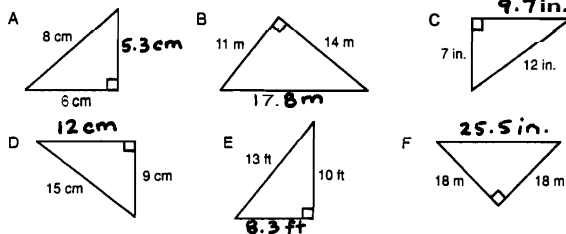

2. Yuki just bought a big-screen TV set. The screen has a diagonal measure of 40 in. If the screen is 32 in. wide, how high is it? 24 in.
3. A 25-foot ladder is leaned against a wall. If the base of the ladder is 7 ft from the wall, how high up the wall will the ladder reach? 24 ft
4. As Greg swam across an 80-meter river, the current carried him 30 m downstream. How far did he swim? 65.4 m
5. The mast of a sailing ship is 20 ft tall. A rope is stretched 26 ft from the top of the mast to a cleat on the deck of the ship. How far is the cleat from the base of the mast? 16.6 ft
6. Each side of an equilateral triangle measures 12 cm. Find the height, h , of the triangle. 10.4 cm
7. Two jets left an airport at the same time. One traveled east at 300 miles per hour. The other traveled south at 400 miles per hour. How far apart were the jets at the end of an hour? 500 m

PI	DO	AS	QR	MA	TE	AM	RU	PF
85.4 m	12 cm	9.8 cm	24 in.	500 m	26 in.	5.3 cm	10.4 cm	520 mi
SN	AR	UN	RA	TH	IN	AT	ER	AN
25.5 in.	9.4 in.	17.8 m	6.6 ft	87.1 m	9.7 in.	24 ft	18.5 ft	8.3 ft

A S T E P F A R T H E R

TOPIC 6-c: The Rule of Pythagoras: Finding the Length of a Side of a Right Triangle

D-76

What Does a BONE SPECIALIST Need to Get His Practice Started?

Evaluate each formula below for the given values of the variables. Find each answer at the left and cross out the letter next to it. When you finish, the answer to the title question will remain.



1. $d = rt$ where d is the distance traveled by an object moving at speed r in time t . Find d if $r = 32$ m/sec, $t = 8$ sec. 256 m
2. $E = IR$ where E is the voltage in an electric circuit with current I and resistance R . Find E if $I = 2.5$ amperes, $R = 60$ ohms. 150 v
3. $v = 9.8t$ where v is the speed in meters per second of a free-falling object after t seconds. Find v if $t = 5$ sec. 49 m/sec
4. $S = (n-2)180$ where S is the sum of the measures of the angles of a polygon with n sides. Find S if $n = 8$. 1,080
5. $A = 6e^2$ where A is the surface area of a cube with edge e . Find A if $e = 12$ cm. cm²
6. $V = hw^2$ where V is the volume of a prism with a square base of side w and height h . Find V if $h = 10$ cm, $w = 7$ cm. cm³
7. $L = \frac{s^2}{30}$ where L is the approximate length of a skid in feet for a car traveling at s miles per hour. Find L if $s = 60$ mi/h. 120 ft
8. $F = 1.8C + 32$ where F is the Fahrenheit temperature equivalent to Celsius temperature C . Find F if $C = 20^\circ$. 68^\circ F
9. $\frac{1}{5}(220 - y)$ where B is the recommended maximum heart rate during exercise for a person y years old. Find B if $y = 15$. beats/sec

D-77

7-a: Formulas

*** Test of Genius ***

1. Identical cubes are stacked in the corner of a room as shown. How many cubes are there altogether? 20
2. Make this equation correct by changing the position of only one digit.
 $101 - 102 = 1$
3. Ms. Smucker went to a store, spent half of her money and then \$10 more. She went to a second store, spent half of her remaining money and then \$10 more. But she then had no money left. How much money did she have to begin with? \$60
4. If 8 widgets equal 4 curlicues and 2 curlicues equal 3 goofups, then 16 widgets equal how many goofups? 12
5. Draw the figure below without lifting your pencil from the page or tracing over a line previously drawn.
6. Steven has 9 gold coins that are identical in appearance. However, one coin is counterfeit and weighs slightly less than the others. Using a balance scale, how can he find the counterfeit coin in just two weighings?
7. In the following addition problem, the letters A, B, and C stand for three different digits. What digit should replace each letter?
8. The teacher noticed there were fewer than 100 students on the playground. When she counted them by 2s, there was 1 student left over. In fact, when Me counted them by 3s, 4s, 5s, or 6s, there was always 1 student left over. How many students were on the playground? 61
9. In the Hope family there are seven sisters, and each sister has one brother. Including Mr. and Mrs. Hope, how many are in the family? 10



$$\begin{array}{r} ABC \\ + ACB \\ \hline CBA \end{array} \quad \begin{array}{l} A=4 \\ B=5 \\ C=9 \end{array}$$

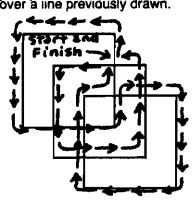

SCORING KEY	
8 or 9	Superstar Genius
6 or 7	Star Genius
4 or 5	Genius
3 or less	Genius of the Future

Divide the coins into 3 sets of 3. Balance 1 set against 1 other. If they balance, take up the 3rd set. If they don't balance, take up the lighter set. Now take any 2 coins from the set left. Balance them against each other. If they balance, the leftover coin is counterfeit. If they don't balance, the lighter coin is counterfeit.

TOPIC 7-b: Test of Genius

D-78