

Circles

11A Lines and Arcs in Circles

- 11-1 Lines That Intersect Circles
- 11-2 Arcs and Chords
- 11-3 Sector Area and Arc Length

CONCEPT CONNECTION

11B Angles and Segments in Circles

- 11-4 Inscribed Angles
- Lab Explore Angle Relationships in Circles
- 11-5 Angle Relationships in Circles
- Lab Explore Segment Relationships in Circles
- 11-6 Segment Relationships in Circles
- 11-7 Circles in the Coordinate Plane
- Ext Polar Coordinates

CONCEPT CONNECTION

 go.hrw.com

Chapter Project Online

KEYWORD: MG7 ChProj

Circles can be seen in the architectural design of the San Diego Convention Center lobby.

Convention Center
San Diego, CA

ARE YOU READY?

Vocabulary

Match each term on the left with a definition on the right.

- | | |
|------------------|---|
| 1. radius | A. the distance around a circle |
| 2. pi | B. the locus of points in a plane that are a fixed distance from a given point |
| 3. circle | C. a segment with one endpoint on a circle and one endpoint at the center of the circle |
| 4. circumference | D. the point at the center of a circle |
| | E. the ratio of a circle's circumference to its diameter |

Tables and Charts

The table shows the number of students in each grade level at Middletown High School. Find each of the following.

- the percentage of students who are freshman
- the percentage of students who are juniors
- the percentage of students who are sophomores or juniors

Year	Number of Students
Freshman	192
Sophomore	208
Junior	216
Senior	184

Circle Graphs

The circle graph shows the age distribution of residents of Mesa, Arizona, according to the 2000 census. The population of the city is 400,000.

- How many residents are between the ages of 18 and 24?
- How many residents are under the age of 18?
- What percentage of the residents are over the age of 45?
- How many residents are over the age of 45?

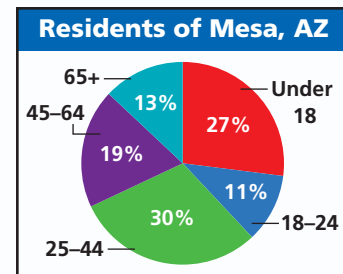

Solve Equations with Variables on Both Sides

Solve each equation.

- | | |
|-------------------------|--------------------------|
| 12. $11y - 8 = 8y + 1$ | 13. $12x + 32 = 10 + x$ |
| 14. $z + 30 = 10z - 15$ | 15. $4y + 18 = 10y + 15$ |
| 16. $-2x - 16 = x + 6$ | 17. $-2x - 11 = -3x - 1$ |



Solve Quadratic Equations

Solve each equation.

- | | |
|------------------------|-----------------------|
| 18. $17 = x^2 - 32$ | 19. $2 + y^2 = 18$ |
| 20. $4x^2 + 12 = 7x^2$ | 21. $188 - 6x^2 = 38$ |

Unpacking the Standards

The information below “unpacks” the standards. The Academic Vocabulary is highlighted and defined to help you understand the language of the standards. Refer to the lessons listed after each standard for help with the math terms and phrases. The Chapter Concept shows how the standard is applied in this chapter.

California Standard	Academic Vocabulary	Chapter Concept
 7.0 Students prove and use theorems involving the properties of parallel lines cut by a transversal, the properties of quadrilaterals, and the properties of circles . (Lessons 11-1, 11-2, 11-4, 11-5, 11-6, 11-7) (Labs 11-5, 11-6)	involving relating to properties unique features	You identify tangents, secants, chords, arcs, and inscribed angles of circles. You find the measures of angles formed when lines intersect circles. Then use these measures and properties of circles to solve problems. You also learn how to use a theorem to write the equation of a circle.
 16.0 Students perform basic constructions with a straightedge and compass , such as angle bisectors, perpendicular bisectors, and the line parallel to a given line through a point off the line. (Lessons 11-1, 11-4)	basic most important or fundamental; used as a starting point	You learn how to construct a tangent to a circle at a point on the circle. You also discover how to locate the center of any circle.
 21.0 Students prove and solve problems regarding relationships among chords, secants, tangents, inscribed angles, and inscribed and circumscribed polygons of circles . (Lessons 11-1, 11-2, 11-3, 11-4, 11-5, 11-6) (Labs 11-5, 11-6)	regarding about relationships connections	You explain the relationship between a chord and a diameter of a circle and compare minor and major arcs. You also use properties of circles to find segment lengths and to prove that arcs and chords are congruent. You calculate the area of a segment and a sector of a circle. You use inscribed angles to find the measures of arcs and other angles.

Standards  1.0 and  8.0 are also covered in this chapter. To see these standards unpacked, go to Chapter 1, p. 4.

Reading Strategy: Read to Solve Problems

A word problem may be overwhelming at first. Once you identify the important parts of the problem and translate the words into math language, you will find that the problem is similar to others you have solved.

Reading Tips:

- ✓ Read each phrase slowly. Write down what the words mean as you read them.
- ✓ Draw a diagram. Label the diagram so it makes sense to you.
- ✓ Read the problem again before finding your solution.
- ✓ Translate the words or phrases into math language.
- ✓ Highlight what is being asked.

From Lesson 10-3: Use the **Reading Tips** to help you understand this problem.

- 14.** After a day hike, a group of hikers set up a camp 3 km east and 7 km north of the starting point. The elevation of the camp is 0.6 km higher than the starting point. What is the distance from the camp to the starting point?

Identify Key Words

After a day hike, a group of hikers set up a camp **3 km east** and **7 km north** of the **starting point**.

The **elevation** of the camp is **0.6 km higher than the starting point**.

What is the **distance** from the **camp** to the **starting point**?

Translate Words into Math

The **starting point** can be represented by the ordered triple $(0, 0, 0)$.

The **camp** can be represented by the ordered triple $(3, 7, 0.6)$.

Distance can be found using the **Distance Formula**.

Draw a Diagram

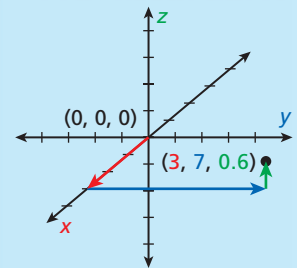

Use the Distance Formula to find the distance between the camp and the starting point.

$$\begin{aligned}
 d &= \sqrt{(x_2 - x_1)^2 + (y_2 - y_1)^2 + (z_2 - z_1)^2} \\
 &= \sqrt{(3 - 0)^2 + (7 - 0)^2 + (0.6 - 0)^2} \approx 7.6 \text{ km}
 \end{aligned}$$

Try This

For the following problem, apply the following reading tips. Do not solve.

- Identify key words.
- Translate each phrase into math language.
- Draw a diagram to represent the problem.

1. The height of a cylinder is 4 ft, and the diameter is 9 ft. What effect does doubling each measure have on the volume?

11-1

Lines That Intersect Circles



Objectives

Identify tangents, secants, and chords.

Use properties of tangents to solve problems.

Vocabulary

interior of a circle
 exterior of a circle
 chord
 secant
 tangent of a circle
 point of tangency
 congruent circles
 concentric circles
 tangent circles
 common tangent

Why learn this?

You can use circle theorems to solve problems about Earth. (See Example 3.)

This photograph was taken 216 miles above Earth. From this altitude, it is easy to see the curvature of the horizon. Facts about circles can help us understand details about Earth.

Recall that a circle is the set of all points in a plane that are equidistant from a given point, called the center of the circle. A circle with center C is called circle C , or $\odot C$.

The **interior of a circle** is the set of all points inside the circle.
 The **exterior of a circle** is the set of all points outside the circle.

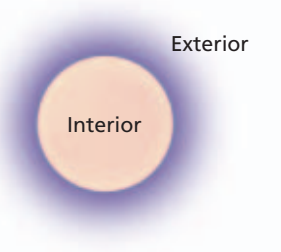

Lines and Segments That Intersect Circles

TERM	DIAGRAM
A chord is a segment whose endpoints lie on a circle.	
A secant is a line that intersects a circle at two points.	
A tangent is a line in the same plane as a circle that intersects it at exactly one point.	
The point where the tangent and a circle intersect is called the point of tangency .	

EXAMPLE 1 Identifying Lines and Segments That Intersect Circles

California Standards

7.0 Students prove and use theorems involving the properties of parallel lines cut by a transversal, the properties of quadrilaterals, and the properties of circles.

21.0 Students prove and solve problems regarding relationships among chords, secants, tangents, inscribed angles, and inscribed and circumscribed polygons of circles.

Also covered: **16.0**

Identify each line or segment that intersects $\odot A$.

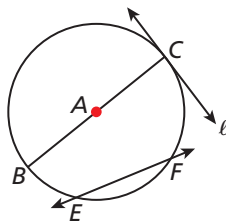

chords: \overline{EF} and \overline{BC}

tangent: l

radii: \overline{AC} and \overline{AB}

secant: \overleftrightarrow{EF}

diameter: \overline{BC}



1. Identify each line or segment that intersects $\odot P$.

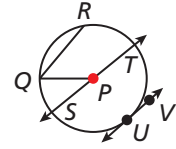

Remember that the terms *radius* and *diameter* may refer to line segments, or to the lengths of segments.



Pairs of Circles

TERM	DIAGRAM
Two circles are congruent circles if and only if they have congruent radii.	<p>$\odot A \cong \odot B$ if $\overline{AC} \cong \overline{BD}$. $\overline{AC} \cong \overline{BD}$ if $\odot A \cong \odot B$.</p>
Concentric circles are coplanar circles with the same center.	
Two coplanar circles that intersect at exactly one point are called tangent circles .	<p style="text-align: center;">Internally tangent circles Externally tangent circles</p>

EXAMPLE 2 Identifying Tangents of Circles

Find the length of each radius. Identify the point of tangency and write the equation of the tangent line at this point.

radius of $\odot A$: 4 Center is $(-1, 0)$. Pt. on \odot is $(3, 0)$. Dist. between the 2 pts. is 4.

radius of $\odot B$: 2 Center is $(1, 0)$. Pt. on \odot is $(3, 0)$. Dist. between the 2 pts. is 2.

point of tangency: $(3, 0)$ Pt. where the \odot s and tangent line intersect

equation of tangent line: $x = 3$ Vert. line through $(3, 0)$

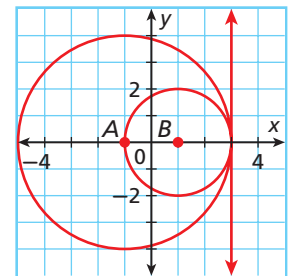

2. Find the length of each radius. Identify the point of tangency and write the equation of the tangent line at this point.

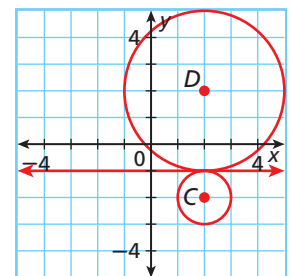

A **common tangent** is a line that is tangent to two circles.

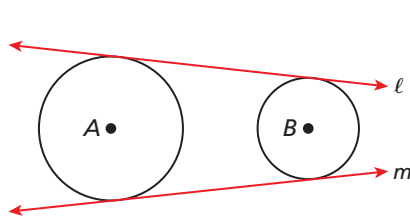

Lines ℓ and m are common external tangents to $\odot A$ and $\odot B$.

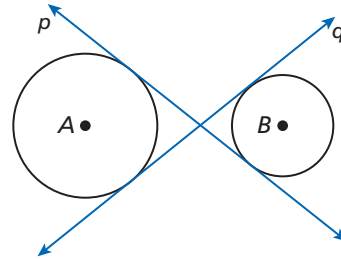

Lines p and q are common internal tangents to $\odot A$ and $\odot B$.



Construction Tangent to a Circle at a Point

1

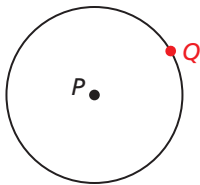

Draw $\odot P$. Locate a point on the circle and label it Q .

2

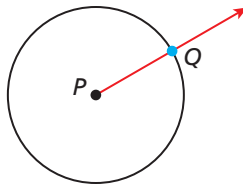

Draw \overrightarrow{PQ} .

3

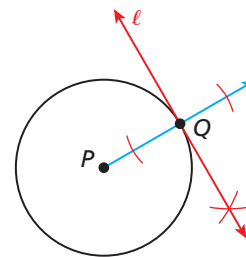

Construct the perpendicular ℓ to \overrightarrow{PQ} at Q . This line is tangent to $\odot P$ at Q .

Notice that in the construction, the tangent line is perpendicular to the radius at the point of tangency. This fact is the basis for the following theorems.



Theorems

Reading Math

Theorem 11-1-2 is the converse of Theorem 11-1-1.

THEOREM	HYPOTHESIS	CONCLUSION
11-1-1 If a line is tangent to a circle, then it is perpendicular to the radius drawn to the point of tangency. (line tangent to $\odot \rightarrow$ line \perp to radius)	<p>ℓ is tangent to $\odot A$</p>	$\ell \perp \overline{AB}$
11-1-2 If a line is perpendicular to a radius of a circle at a point on the circle, then the line is tangent to the circle. (line \perp to radius \rightarrow line tangent to \odot)	<p>m is \perp to \overline{CD} at D</p>	m is tangent to $\odot C$.

You will prove Theorems 11-1-1 and 11-1-2 in Exercises 28 and 29.

EXAMPLE 3 Problem Solving Application



The summit of Mount Everest is approximately 29,000 ft above sea level. What is the distance from the summit to the horizon to the nearest mile?

1 Understand the Problem

The answer will be the length of an imaginary segment from the summit of Mount Everest to Earth's horizon.

2 Make a Plan

Draw a sketch. Let C be the center of Earth, E be the summit of Mount Everest, and H be a point on the horizon. You need to find the length of \overline{EH} , which is tangent to $\odot C$ at H . By Theorem 11-1-1, $\overline{EH} \perp \overline{CH}$. So $\triangle CHE$ is a right triangle.

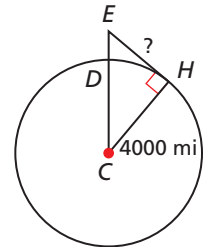

Helpful Hint

5280 ft = 1 mi
Earth's radius \approx 4000 mi

3 Solve

$$\begin{aligned} ED &= 29,000 \text{ ft} \\ &= \frac{29,000}{5280} \approx 5.49 \text{ mi} \end{aligned}$$

$$\begin{aligned} EC &= CD + ED \\ &= 4000 + 5.49 = 4005.49 \text{ mi} \end{aligned}$$

$$\begin{aligned} EC^2 &= EH^2 + CH^2 \\ 4005.49^2 &= EH^2 + 4000^2 \end{aligned}$$

$$43,950.14 \approx EH^2$$

$$210 \text{ mi} \approx EH$$

Given

Change ft to mi.

Seg. Add. Post.

Substitute 4000 for CD and 5.49 for ED.

Pyth. Thm.

Substitute the given values.

Subtract 4000^2 from both sides.

Take the square root of both sides.

4 Look Back

The problem asks for the distance to the nearest mile. Check if your answer is reasonable by using the Pythagorean Theorem. Is $210^2 + 4000^2 \approx 4005^2$? Yes, $16,044,100 \approx 16,040,025$.



3. Kilimanjaro, the tallest mountain in Africa, is 19,340 ft tall. What is the distance from the summit of Kilimanjaro to the horizon to the nearest mile?



Theorem 11-1-3

THEOREM	HYPOTHESIS	CONCLUSION
If two segments are tangent to a circle from the same external point, then the segments are congruent. (2 segs. tangent to \odot from same ext. pt. \rightarrow segs. \cong)	<p>\overline{AB} and \overline{AC} are tangent to $\odot P$.</p>	$\overline{AB} \cong \overline{AC}$

You will prove Theorem 11-1-3 in Exercise 30.

You can use Theorem 11-1-3 to find the length of segments drawn tangent to a circle from an exterior point.

EXAMPLE 4 Using Properties of Tangents

\overline{DE} and \overline{DF} are tangent to $\odot C$. Find DF .

$$DE = DF \quad \text{2 segs. tangent to } \odot \text{ from same ext. pt. } \rightarrow \text{ segs. } \cong.$$

$$5y - 28 = 3y \quad \text{Substitute } 5y - 28 \text{ for } DE \text{ and } 3y \text{ for } DF.$$

$$2y - 28 = 0 \quad \text{Subtract } 3y \text{ from both sides.}$$

$$2y = 28 \quad \text{Add } 28 \text{ to both sides.}$$

$$y = 14 \quad \text{Divide both sides by } 2.$$

$$DF = 3(14) \quad \text{Substitute } 14 \text{ for } y.$$

$$= 42 \quad \text{Simplify.}$$

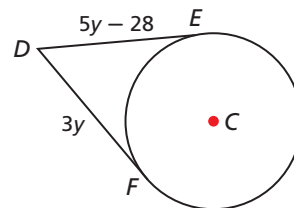

\overline{RS} and \overline{RT} are tangent to $\odot Q$. Find RS .

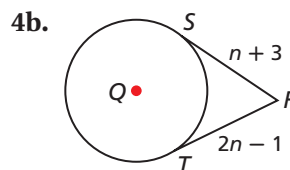
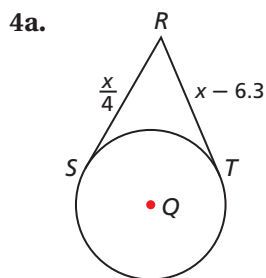

THINK AND DISCUSS

1. Consider $\odot A$ and $\odot B$. How many different lines are common tangents to both circles? Copy the circles and sketch the common external and common internal tangent lines.
2. Is it possible for a line to be tangent to two concentric circles? Explain your answer.
3. Given $\odot P$, is the center P a part of the circle? Explain your answer.
4. In the figure, \overline{RQ} is tangent to $\odot P$ at Q . Explain how you can find $m\angle PRQ$.

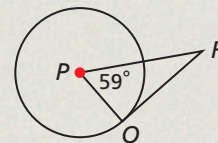
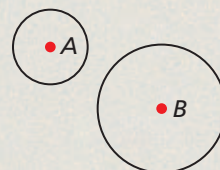

5. **GET ORGANIZED** Copy and complete the graphic organizer below. In each box, write a definition and draw a sketch.

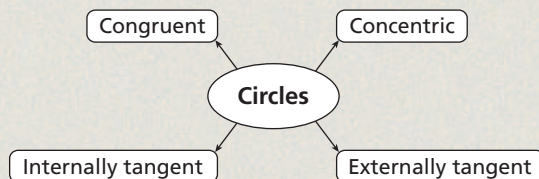

GUIDED PRACTICE

Vocabulary Apply the vocabulary from this lesson to answer each question.

1. A ? is a line in the plane of a circle that intersects the circle at two points.
 (*secant or tangent*)
2. Coplanar circles that have the same center are called ? .
 (*concentric or congruent*)
3. $\odot Q$ and $\odot R$ both have a radius of 3 cm. Therefore the circles are ? .
 (*concentric or congruent*)

SEE EXAMPLE 1

Identify each line or segment that intersects each circle.

p. 746

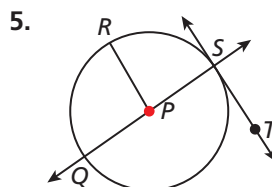
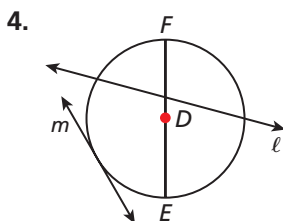

SEE EXAMPLE 2

Multi-Step Find the length of each radius. Identify the point of tangency and write the equation of the tangent line at this point.

p. 747

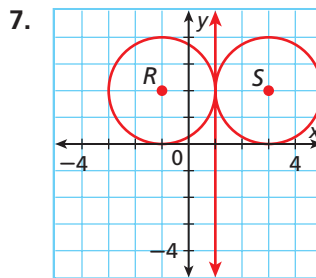
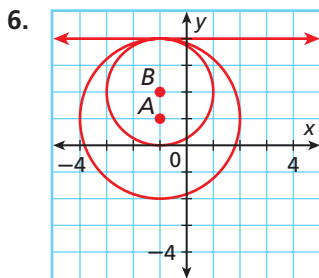

SEE EXAMPLE 3

8. **Space Exploration** The International Space Station orbits Earth at an altitude of 240 mi. What is the distance from the space station to Earth's horizon to the nearest mile?

p. 749



SEE EXAMPLE 4

The segments in each figure are tangent to the circle. Find each length.

p. 750

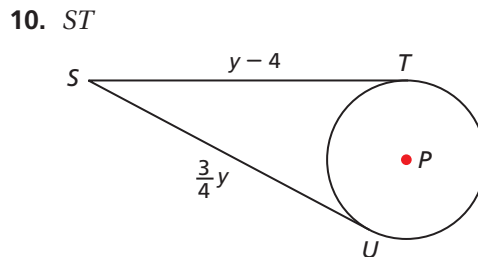
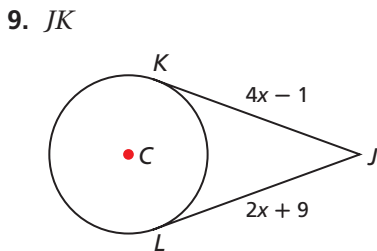

PRACTICE AND PROBLEM SOLVING

Independent Practice

For Exercises	See Example
11–12	1
13–14	2
15	3
16–17	4

Extra Practice

Skills Practice p. S24

Application Practice p. S38

Identify each line or segment that intersects each circle.

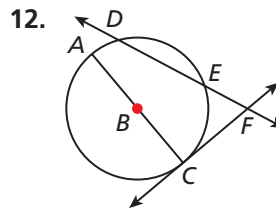
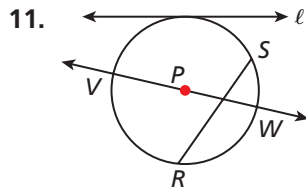

Multi-Step Find the length of each radius. Identify the point of tangency and write the equation of the tangent line at this point.

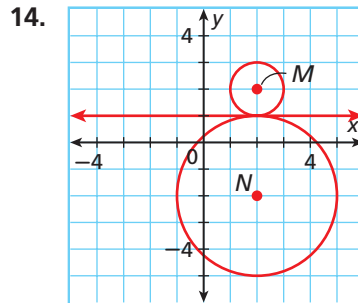
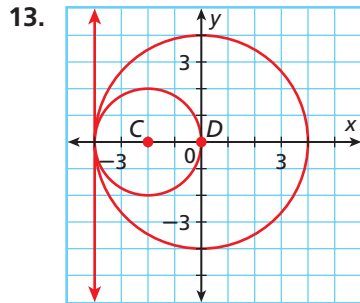

Astronomy



Olympus Mons, located on Mars, is the tallest known volcano in the solar system.

15. Astronomy Olympus Mons's peak rises 25 km above the surface of the planet Mars. The diameter of Mars is approximately 6794 km. What is the distance from the peak of Olympus Mons to the horizon to the nearest kilometer?

The segments in each figure are tangent to the circle. Find each length.

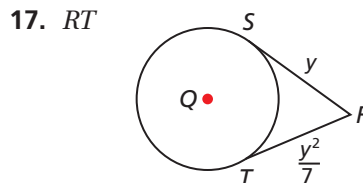
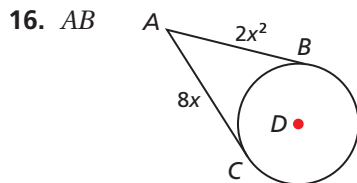

Tell whether each statement is sometimes, always, or never true.

18. Two circles with the same center are congruent.
19. A tangent to a circle intersects the circle at two points.
20. Tangent circles have the same center.
21. A tangent to a circle will form a right angle with a radius that is drawn to the point of tangency.
22. A chord of a circle is a diameter.

Graphic Design Use the following diagram for Exercises 23–25.

The peace symbol was designed in 1958 by Gerald Holtom, a professional artist and designer. Identify the following.

23. diameter
24. radii
25. chord

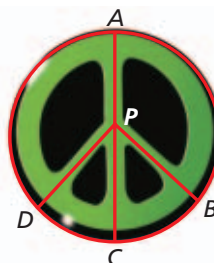

In each diagram, \overline{PR} and \overline{PS} are tangent to $\odot Q$. Find each angle measure.

26. $m\angle Q$

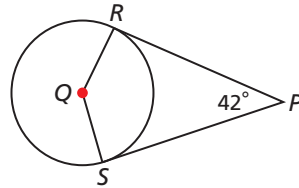

27. $m\angle P$

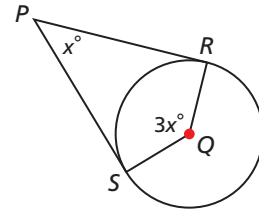

28. Complete this indirect proof of Theorem 11-1-1.

Given: ℓ is tangent to $\odot A$ at point B .

Prove: $\ell \perp \overline{AB}$

Proof: Assume that ℓ is not $\perp \overline{AB}$. Then it is possible to draw \overline{AC} such that $\overline{AC} \perp \ell$. If this is true, then $\triangle ACB$ is a right triangle. $AC < AB$ because **a.** $\underline{\quad ? \quad}$. Since ℓ is a tangent line, it can only intersect $\odot A$ at **b.** $\underline{\quad ? \quad}$, and C must be in the exterior of $\odot A$. That means that $AC > AB$ since \overline{AB} is a **c.** $\underline{\quad ? \quad}$. This contradicts the fact that $AC < AB$. Thus the assumption is false, and **d.** $\underline{\quad ? \quad}$.

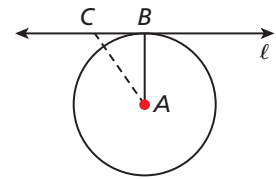

29. Prove Theorem 11-1-2.

Given: $m \perp \overline{CD}$

Prove: m is tangent to $\odot C$.

(Hint: Choose a point on m . Then use the Pythagorean Theorem to prove that if the point is not D , then it is not on the circle.)

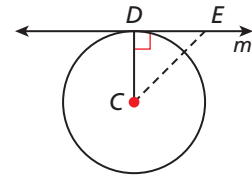

30. Prove Theorem 11-1-3.

Given: \overline{AB} and \overline{AC} are tangent to $\odot P$.

Prove: $\overline{AB} \cong \overline{AC}$

Plan: Draw auxiliary segments \overline{PA} , \overline{PB} , and \overline{PC} . Show that the triangles formed are congruent. Then use CPCTC.

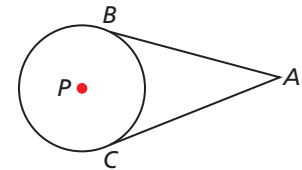

Algebra Assume the segments that appear to be tangent are tangent. Find each length.

31. ST

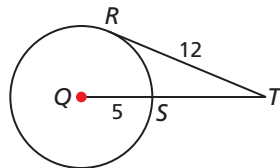

32. DE

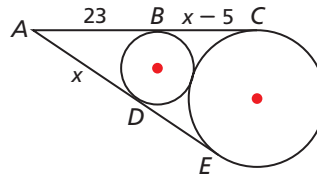

33. JL

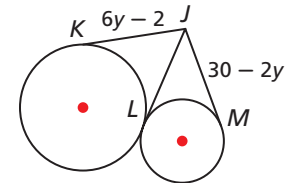

34. $\odot M$ has center $M(2, 2)$ and radius 3. $\odot N$ has center $N(-3, 2)$ and is tangent to $\odot M$. Find the coordinates of the possible points of tangency of the two circles.

CONCEPT CONNECTION



35. This problem will prepare you for the Concept Connection on page 770.

The diagram shows the gears of a bicycle. $AD = 5$ in., and $BC = 3$ in. CD , the length of the chain between the gears, is 17 in.

- What type of quadrilateral is $BCDE$? Why?
- Find BE and AE .
- What is AB to the nearest tenth of an inch?

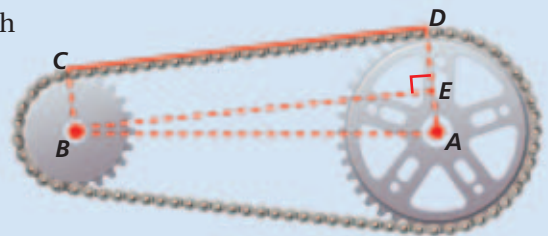

36. **Critical Thinking** Given a circle with diameter \overline{BC} , is it possible to draw tangents to B and C from an external point X ? If so, make a sketch. If not, explain why it is not possible.



37. **Write About It** \overline{PR} and \overline{PS} are tangent to $\odot Q$. Explain why $\angle P$ and $\angle Q$ are supplementary.

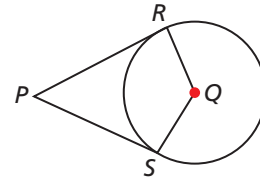

38. \overline{AB} and \overline{AC} are tangent to $\odot D$. Which of these is closest to AD ?

- (A) 9.5 cm (C) 10.4 cm
(B) 10 cm (D) 13 cm

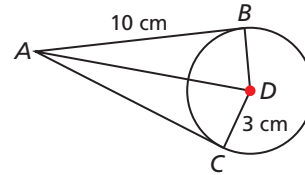

39. $\odot P$ has center $P(3, -2)$ and radius 2. Which of these lines is tangent to $\odot P$?

- (F) $x = 0$ (G) $y = -4$ (H) $y = -2$ (J) $x = 4$

40. $\odot A$ has radius 5. $\odot B$ has radius 6. What is the ratio of the area of $\odot A$ to that of $\odot B$?

- (A) $\frac{125}{216}$ (B) $\frac{25}{36}$ (C) $\frac{5}{6}$ (D) $\frac{36}{25}$

CHALLENGE AND EXTEND

41. **Given:** $\odot G$ with $\overline{GH} \perp \overline{JK}$
Prove: $\overline{JH} \cong \overline{KH}$

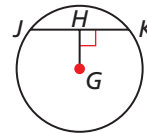

42. **Multi-Step** $\odot A$ has radius 5, $\odot B$ has radius 2, and \overline{CD} is a common tangent. What is AB ?
(Hint: Draw a perpendicular segment from B to E , a point on \overline{AC} .)

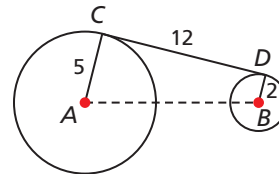

43. **Manufacturing** A company builds metal stands for bicycle wheels. A new design calls for a V-shaped stand that will hold wheels with a 13 in. radius. The sides of the stand form a 70° angle. To the nearest tenth of an inch, what should be the length XY of a side so that it is tangent to the wheel?

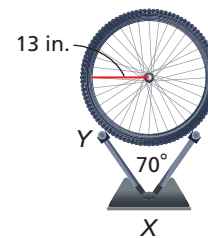

SPIRAL REVIEW

44. Andrea and Carlos both mow lawns. Andrea charges \$14.00 plus \$6.25 per hour. Carlos charges \$12.50 plus \$6.50 per hour. If they both mow h hours and Andrea earns more money than Carlos, what is the range of values of h ? (*Previous course*)

A point is chosen randomly on \overline{LR} . Use the diagram to find the probability of each event. (*Lesson 9-6*)

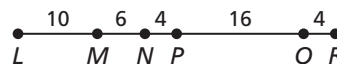

45. The point is not on \overline{MP} . 46. The point is on \overline{LP} .
47. The point is on \overline{MN} or \overline{PR} . 48. The point is on \overline{QR} .

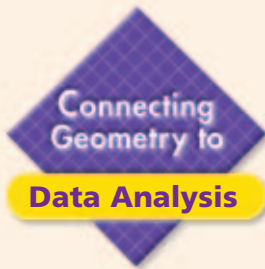

Circle Graphs

Connecting
Geometry to

Data Analysis

See Skills Bank
page S80

A circle graph compares data that are parts of a whole unit. When you make a circle graph, you find the measure of each *central angle*.

A *central angle* is an angle whose vertex is the center of the circle.



California Standards

Review of 7SDAP1.1 Know various forms of display for data sets, including a stem-and-leaf plot or box-and-whisker plot; use the forms to display a single set of data or to compare two sets of data.

Example

Make a circle graph to represent the following data.

Step 1 Add all the amounts. $110 + 40 + 300 + 150 = 600$

Step 2 Write each part as a fraction of the whole.

$$\text{fiction: } \frac{110}{600}; \text{ nonfiction: } \frac{40}{600}; \text{ children's: } \frac{300}{600}; \text{ audio books: } \frac{150}{600}$$

Step 3 Multiply each fraction by 360° to calculate the central angle measure.

$$\frac{110}{600}(360^\circ) = 66^\circ; \frac{40}{600}(360^\circ) = 24^\circ; \frac{300}{600}(360^\circ) = 180^\circ; \frac{150}{600}(360^\circ) = 90^\circ$$

Step 4 Make a circle graph. Then color each section of the circle to match the data.

Books in the Bookmobile	
Fiction	110
Nonfiction	40
Children's	300
Audio books	150



The section with a central angle of 66° is green, 24° is orange, 180° is purple, and 90° is yellow.

Try This

Choose the circle graph that best represents the data. Show each step.

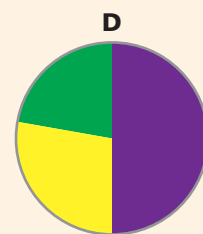
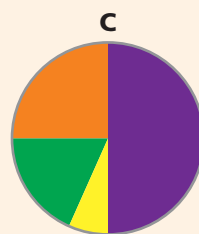
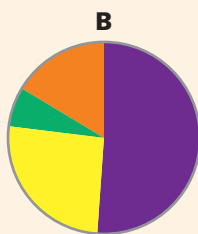
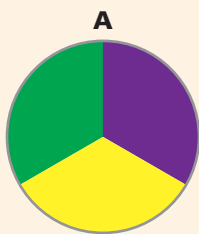

1. **Books in Linda's Library**

Novels	18
Reference	10
Textbooks	8

2. **Vacation Expenses (\$)**

Travel	450
Meals	120
Lodging	900
Other	330

3. **Puppy Expenses (\$)**

Food	190
Health	375
Training	120
Other	50

11-2

Arcs and Chords



Objectives

Apply properties of arcs.
Apply properties of chords.

Vocabulary

central angle
arc
minor arc
major arc
semicircle
adjacent arcs
congruent arcs

Who uses this?

Market analysts use circle graphs to compare sales of different products.

A **central angle** is an angle whose vertex is the center of a circle. An **arc** is an unbroken part of a circle consisting of two points called the endpoints and all the points on the circle between them.



Writing Math

Minor arcs may be named by two points. Major arcs and semicircles must be named by three points.

Arcs and Their Measure

ARC	MEASURE	DIAGRAM
A minor arc is an arc whose points are on or in the interior of a central angle.	The measure of a minor arc is equal to the measure of its central angle. $m\widehat{AC} = m\angle ABC = x^\circ$	
A major arc is an arc whose points are on or in the exterior of a central angle.	The measure of a major arc is equal to 360° minus the measure of its central angle. $m\widehat{ADC} = 360^\circ - m\angle ABC = 360^\circ - x^\circ$	
If the endpoints of an arc lie on a diameter, the arc is a semicircle .	The measure of a semicircle is equal to 180°. $m\widehat{EFG} = 180^\circ$	

EXAMPLE 1 Data Application

California Standards

7.0 Students prove and use theorems involving the properties of parallel lines cut by a transversal, the properties of quadrilaterals, and the properties of circles.
21.0 Students prove and solve problems regarding relationships among chords, secants, tangents, inscribed angles, and inscribed and circumscribed polygons of circles.

The circle graph shows the types of music sold during one week at a music store.

Find $m\widehat{BC}$.

$$m\widehat{BC} = m\angle BMC$$

$$m\angle BMC = 0.13(360^\circ) = 46.8^\circ$$

m of arc = m of central \angle .

Central \angle is 13% of the \odot .

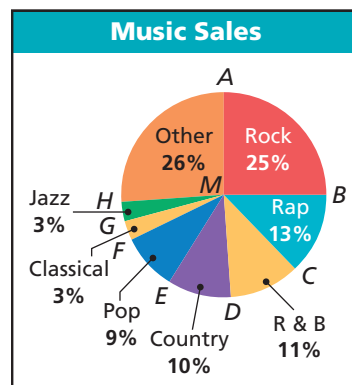

Use the graph to find each of the following.

1a. $m\angle FMC$

1b. $m\widehat{AHB}$

1c. $m\angle EMD$

Adjacent arcs are arcs of the same circle that intersect at exactly one point. \widehat{RS} and \widehat{ST} are adjacent arcs.

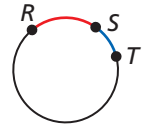

Postulate 11-2-1 Arc Addition Postulate

The measure of an arc formed by two adjacent arcs is the sum of the measures of the two arcs.

$$m\widehat{ABC} = m\widehat{AB} + m\widehat{BC}$$

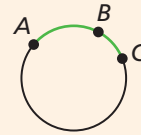

EXAMPLE 2 Using the Arc Addition Postulate

Find $m\widehat{CDE}$

$$m\widehat{CD} = 90^\circ$$

$$m\angle DFE = 18^\circ$$

$$m\widehat{DE} = 18^\circ$$

$$m\widehat{CE} = m\widehat{CD} + m\widehat{DE}$$

$$= 90^\circ + 18^\circ = 108^\circ$$

$$m\angle CFD = 90^\circ$$

Vert. \triangle Thm.

$$m\angle DFE = 18^\circ$$

Arc Add. Post.

Substitute and simplify.

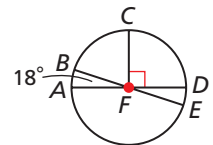

Find each measure.

2a. $m\widehat{KL}$

2b. $m\widehat{LJN}$

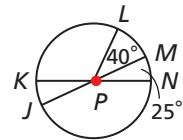

Within a circle or congruent circles, **congruent arcs** are two arcs that have the same measure. In the figure, $\widehat{ST} \cong \widehat{UV}$.

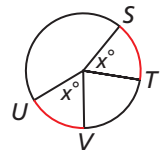

Theorem 11-2-2

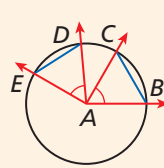
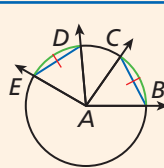
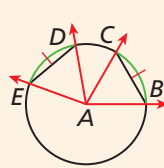
THEOREM	HYPOTHESIS	CONCLUSION
In a circle or congruent circles: (1) Congruent central angles have congruent chords.	 $\angle EAD \cong \angle BAC$	$\overline{DE} \cong \overline{BC}$
(2) Congruent chords have congruent arcs.	 $\overline{ED} \cong \overline{BC}$	$\widehat{DE} \cong \widehat{BC}$
(3) Congruent arcs have congruent central angles.	 $\widehat{ED} \cong \widehat{BC}$	$\angle DAE \cong \angle BAC$

You will prove parts 2 and 3 of Theorem 11-2-2 in Exercises 40 and 41.

The converses of the parts of Theorem 11-2-2 are also true. For example, with part 1, congruent chords have congruent central angles.

PROOF **Theorem 11-2-2 (Part 1)**

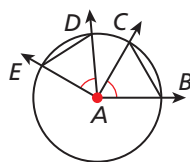

Given: $\angle BAC \cong \angle DAE$
 Prove: $\overline{BC} \cong \overline{DE}$

Proof:

Statements	Reasons
1. $\angle BAC \cong \angle DAE$	1. Given
2. $\overline{AB} \cong \overline{AD}, \overline{AC} \cong \overline{AE}$	2. All radii of a \odot are \cong .
3. $\triangle BAC \cong \triangle DAE$	3. SAS Steps 2, 1
4. $\overline{BC} \cong \overline{DE}$	4. CPCTC

EXAMPLE 3 **Applying Congruent Angles, Arcs, and Chords**



Find each measure.

- A** $\overline{RS} \cong \overline{TU}$. Find $m\widehat{RS}$.
- $\widehat{RS} \cong \widehat{TU}$ \cong chords have \cong arcs.
 $m\widehat{RS} = m\widehat{TU}$ Def. of \cong arcs
 $3x = 2x + 27$ Substitute the given measures.
 $x = 27$ Subtract $2x$ from both sides.
 $m\widehat{RS} = 3(27)$ Substitute 27 for x .
 $= 81^\circ$ Simplify.

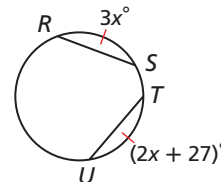

- B** $\odot B \cong \odot E$, and $\widehat{AC} \cong \widehat{DF}$. Find $m\angle DEF$.
- $\angle ABC \cong \angle DEF$ \cong arcs have \cong central \angle s.
 $m\angle ABC = m\angle DEF$ Def. of \cong \angle s
 $5y + 5 = 7y - 43$ Substitute the given measures.
 $5 = 2y - 43$ Subtract $5y$ from both sides.
 $48 = 2y$ Add 43 to both sides.
 $24 = y$ Divide both sides by 2.
 $m\angle DEF = 7(24) - 43$ Substitute 24 for y .
 $= 125^\circ$ Simplify.

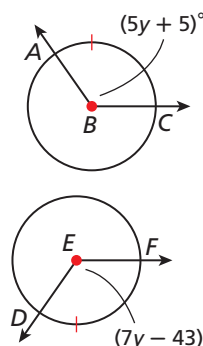

Find each measure.

- 3a. \overline{PT} bisects $\angle RPS$. Find RT .

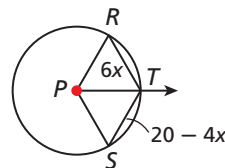

- 3b. $\odot A \cong \odot B$, and $\overline{CD} \cong \overline{EF}$.
 Find $m\widehat{CD}$.

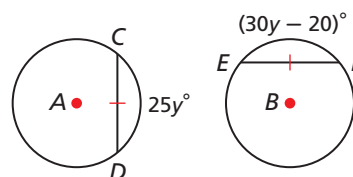



Theorems

THEOREM	HYPOTHESIS	CONCLUSION
11-2-3 In a circle, if a radius (or diameter) is perpendicular to a chord, then it bisects the chord and its arc.	 $\overline{CD} \perp \overline{EF}$	\overline{CD} bisects \overline{EF} and \widehat{EF} .
11-2-4 In a circle, the perpendicular bisector of a chord is a radius (or diameter).	 \overline{JK} is \perp bisector of \overline{GH} .	\overline{JK} is a diameter of $\odot A$.

You will prove Theorems 11-2-3 and 11-2-4 in Exercises 42 and 43.

EXAMPLE 4 Using Radii and Chords



Find BD .

Step 1 Draw radius \overline{AD} .

$$AD = 5$$

Radii of a \odot are \cong .

Step 2 Use the Pythagorean Theorem.

$$CD^2 + AC^2 = AD^2$$

$$CD^2 + 3^2 = 5^2$$

$$CD^2 = 16$$

$$CD = 4$$

Substitute 3 for AC and 5 for AD.

Subtract 3^2 from both sides.

Take the square root of both sides.

Step 3 Find BD .

$$BD = 2(4) = 8$$

$\overline{AE} \perp \overline{BD}$, so \overline{AE} bisects \overline{BD} .

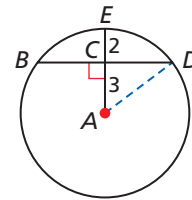

4. Find QR to the nearest tenth.

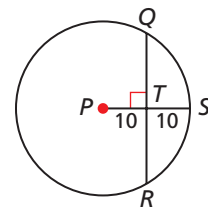

THINK AND DISCUSS

- What is true about the measure of an arc whose central angle is obtuse?
- Under what conditions are two arcs the same measure but not congruent?
- GET ORGANIZED** Copy and complete the graphic organizer. In each box, write a definition and draw a sketch.

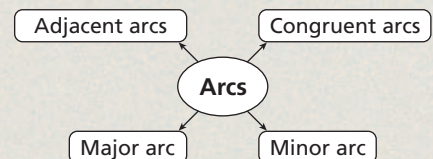



- 1.0, 7.0, 16.0,
- 21.0, 7SDAP1.1, 7AF2.0,
- 7AF4.1, 1A2.0



GUIDED PRACTICE

Vocabulary Apply the vocabulary from this lesson to answer each question.

- An arc that joins the endpoints of a diameter is called a ? . (*semicircle* or *major arc*)
- How do you recognize a *central angle* of a circle?
- In $\odot P$ $m\widehat{ABC} = 205^\circ$. Therefore \widehat{ABC} is a ? . (*major arc* or *minor arc*)
- In a circle, an arc that is less than a semicircle is a ? . (*major arc* or *minor arc*)

SEE EXAMPLE 1

p. 756

Consumer Application Use the following information for Exercises 5–10.

The circle graph shows how a typical household spends money on energy. Find each of the following.

- $m\angle PAQ$
- $m\angle SAQ$
- $m\widehat{RQ}$
- $m\angle VAU$
- $m\widehat{UT}$
- $m\widehat{UPT}$

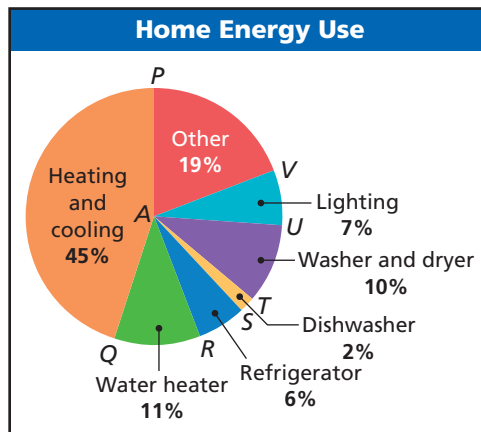

SEE EXAMPLE 2

p. 757

Find each measure.

- $m\widehat{DF}$
- $m\widehat{DEB}$

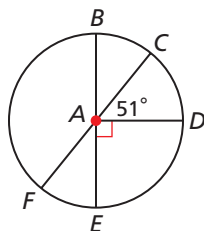

- $m\widehat{JL}$

- $m\widehat{HLK}$

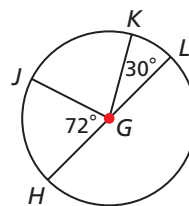

SEE EXAMPLE 3

p. 758

15. $\angle QPR \cong \angle RPS$. Find QR .

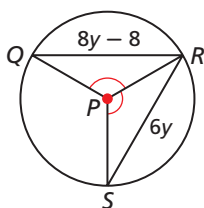

16. $\odot A \cong \odot B$, and $\widehat{CD} \cong \widehat{EF}$. Find $m\angle EBF$.

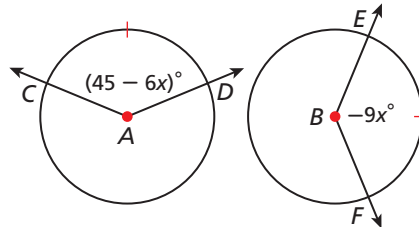

SEE EXAMPLE 4

p. 759

Multi-Step Find each length to the nearest tenth.

- RS

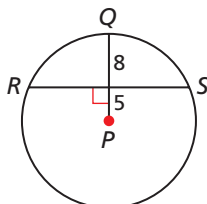

- EF

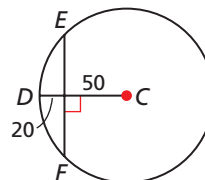

PRACTICE AND PROBLEM SOLVING

Independent Practice

For Exercises	See Example
19–24	1
25–28	2
29–30	3
31–32	4

Extra Practice

Skills Practice p. S24
Application Practice p. S38

Sports Use the following information for Exercises 19–24.

The key shows the number of medals won by U.S. athletes at the 2004 Olympics in Athens. Find each of the following to the nearest tenth.

Medals	
Gold	35
Silver	39
Bronze	29

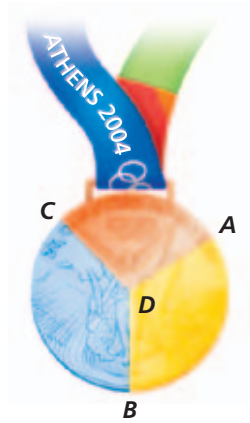

19. $m\angle ADB$ 20. $m\angle ADC$
 21. $m\widehat{AB}$ 22. $m\widehat{BC}$
 23. $m\widehat{ACB}$ 24. $m\widehat{CAB}$

Find each measure.

25. $m\widehat{MP}$
 26. $m\widehat{QNL}$

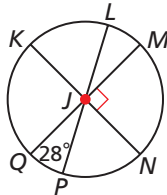

27. $m\widehat{WT}$
 28. $m\widehat{WTV}$

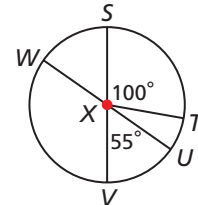

29. $\odot A \cong \odot B$, and
 $\widehat{CD} \cong \widehat{EF}$.
 Find $m\angle CAD$.

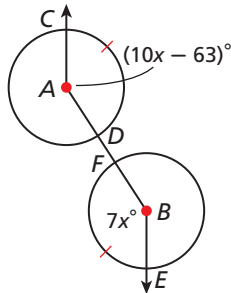

30. $\overline{JK} \cong \overline{LM}$. Find $m\widehat{JK}$.

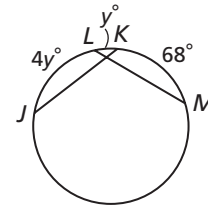

Multi-Step Find each length to the nearest tenth.

31. CD

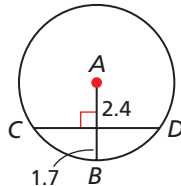

32. RS

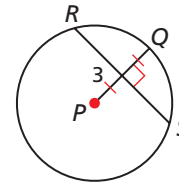

Determine whether each statement is true or false. If false, explain why.

33. The central angle of a minor arc is an acute angle.
 34. Any two points on a circle determine a minor arc and a major arc.
 35. In a circle, the perpendicular bisector of a chord must pass through the center of the circle.
 36. **Data Collection** Use a graphing calculator, a pH probe, and a data-collection device to collect information about the pH levels of ten different liquids. Then create a circle graph with the following sectors: strong basic ($9 < \text{pH} < 14$), weak basic ($7 < \text{pH} < 9$), neutral ($\text{pH} = 7$), weak acidic ($5 < \text{pH} < 7$), and strong acidic ($0 < \text{pH} < 5$).
 37. In $\odot E$, the measures of $\angle AEB$, $\angle BEC$, and $\angle CED$ are in the ratio 3:4:5. Find $m\widehat{AB}$, $m\widehat{BC}$, and $m\widehat{CD}$.

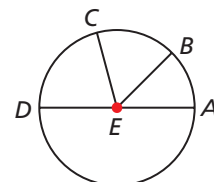

Algebra Find the indicated measure.

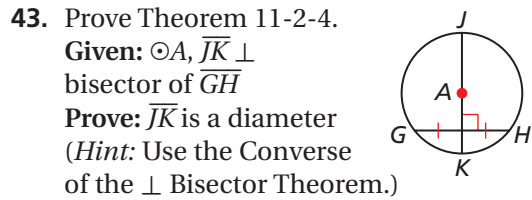
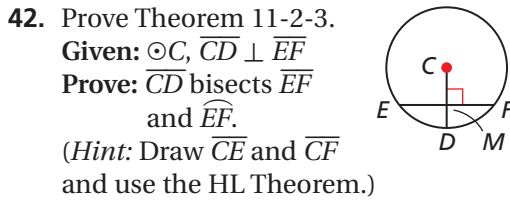
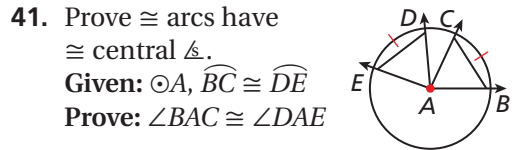
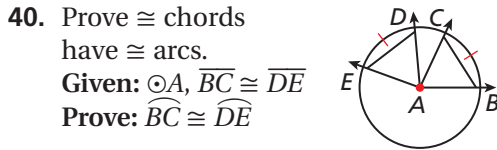
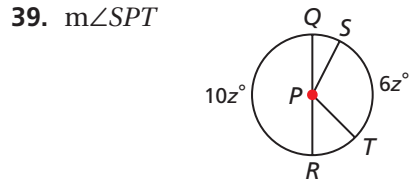
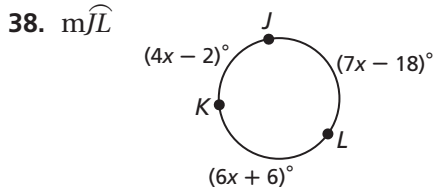

44. **Critical Thinking** Roberto folds a circular piece of paper as shown. When he unfolds the paper, how many different-sized central angles will be formed?

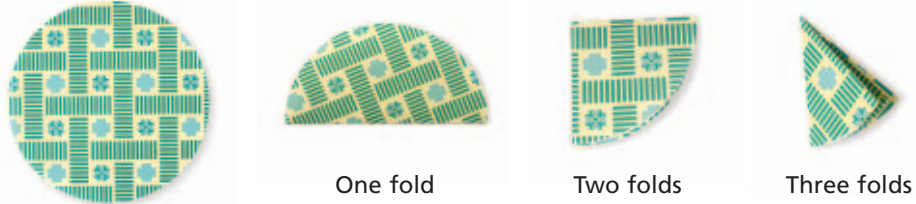

45. **ERROR ANALYSIS** Below are two solutions to find the value of x . Which solution is incorrect? Explain the error.

A

\overline{AD} is a diam., so $m\widehat{ACD} = 180^\circ$. $m\widehat{AB} + m\widehat{BC} + m\widehat{CD} = 180^\circ$.
 $5x + 90 + 15x = 180$.
 $20x = 90$. $x = 4.5$.

B

Because they are vert. \angle , $\angle AGF \cong \angle CGD$. Thus $m\widehat{AF} = m\widehat{CD}$.
 $16x - 5 = 15x$.
 $x = 5$.

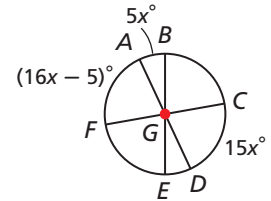

46. **Write About It** According to a school survey, 40% of the students take a bus to school, 35% are driven to school, 15% ride a bike, and the remainder walk. Explain how to use central angles to create a circle graph from this data.

CONCEPT CONNECTION



47. This problem will prepare you for the Concept Connection on page 770.
 Chantal's bike has wheels with a 27 in. diameter.
 a. What are AC and AD if DB is 7 in.?
 b. What is CD to the nearest tenth of an inch?
 c. What is CE , the length of the top of the bike stand?

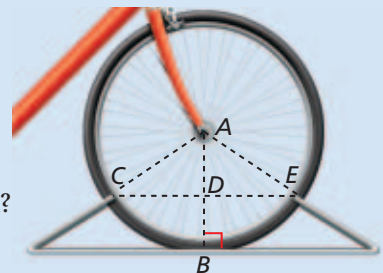

48. Which of these arcs of $\odot Q$ has the greatest measure?

- (A) \widehat{WT} (C) \widehat{VR}
 (B) \widehat{UW} (D) \widehat{TV}

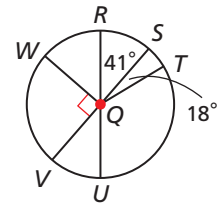

49. In $\odot A$, $CD = 10$. Which of these is closest to the length of \overline{AE} ?

- (F) 3.3 cm (H) 5 cm
 (G) 4 cm (J) 7.8 cm

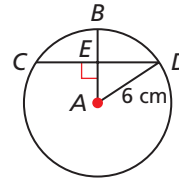

50. **Gridded Response** $\odot P$ has center $P(2, 1)$ and radius 3. What is the measure, in degrees, of the minor arc with endpoints $A(-1, 1)$ and $B(2, -2)$?

CHALLENGE AND EXTEND

51. In the figure, $\overline{AB} \perp \overline{CD}$. Find $m\widehat{BD}$ to the nearest tenth of a degree.

52. Two points on a circle determine two distinct arcs. How many arcs are determined by n points on a circle? (*Hint:* Make a table and look for a pattern.)

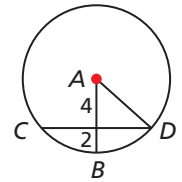

53. An angle measure other than degrees is *radian* measure. 360° converts to 2π radians, or 180° converts to π radians.

- a. Convert the following radian angle measures to degrees: $\frac{\pi}{2}, \frac{\pi}{3}, \frac{\pi}{4}$.
 b. Convert the following angle measures to radians: $135^\circ, 270^\circ$.

SPIRAL REVIEW

Simplify each expression. (*Previous course*)

54. $(3x)^3(2y^2)(3^{-2}y^2)$ 55. $a^4b^3(-2a)^{-4}$ 56. $(-2t^3s^2)(3ts^2)^2$

Find the next term in each pattern. (*Lesson 2-1*)

57. 1, 3, 7, 13, 21, ... 58. C, E, G, I, K, ... 59. 1, 6, 15, ...

In the figure, \overline{QP} and \overline{QM} are tangent to $\odot N$. Find each measure. (*Lesson 11-1*)

60. $m\angle NMQ$ 61. MQ

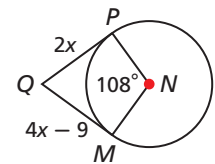

Construction Circle Through Three Noncollinear Points

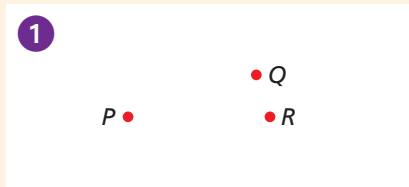

Draw three noncollinear points.

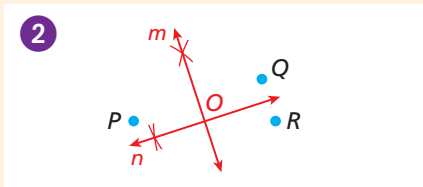

Construct m and n , the \perp bisectors of \overline{PQ} and \overline{QR} . Label the intersection O .

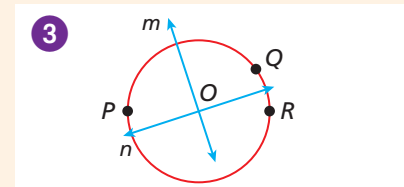

Center the compass at O . Draw a circle through P .

1. Explain why $\odot O$ with radius \overline{OP} also contains Q and R .

11-3

Sector Area and Arc Length

Objectives

Find the area of sectors.
Find arc lengths.

Vocabulary

sector of a circle
segment of a circle
arc length

Who uses this?

Farmers use irrigation radii to calculate areas of sectors. (See Example 2.)

The area of a sector is a fraction of the circle containing the sector. To find the area of a sector whose central angle measures m° , multiply the area of the circle by $\frac{m^\circ}{360^\circ}$.



Sector of a Circle

TERM	NAME	DIAGRAM	AREA
A sector of a circle is a region bounded by two radii of the circle and their intercepted arc.	sector ACB		$A = \pi r^2 \left(\frac{m^\circ}{360^\circ} \right)$

EXAMPLE 1 Finding the Area of a Sector

Find the area of each sector. Give your answer in terms of π and rounded to the nearest hundredth.

A sector MPN

$$A = \pi r^2 \left(\frac{m^\circ}{360^\circ} \right)$$

Use formula for area of a sector.

$$= \pi (3)^2 \left(\frac{80^\circ}{360^\circ} \right)$$

Substitute 3 for r and 80 for m .

$$= 2\pi \text{ in}^2 \approx 6.28 \text{ in}^2$$

Simplify.

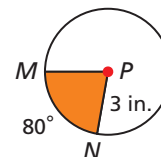

B sector EFG

$$A = \pi r^2 \left(\frac{m^\circ}{360^\circ} \right)$$

Use formula for area of a sector.

$$= \pi (6)^2 \left(\frac{120^\circ}{360^\circ} \right)$$

Substitute 6 for r and 120 for m .

$$= 12\pi \approx 37.70 \text{ cm}^2$$

Simplify.

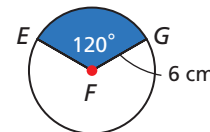

Helpful Hint

Write the degree symbol after m in the formula to help you remember to use degree measure not arc length.

California Standards

8.0 Students know, derive, and solve problems involving the perimeter, circumference, area, volume, lateral area, and surface area of common geometric figures.

21.0 Students prove and solve problems regarding relationships among chords, secants, tangents, inscribed angles, and inscribed and circumscribed polygons of circles.



Find the area of each sector. Give your answer in terms of π and rounded to the nearest hundredth.

1a. sector ACB

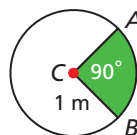

1b. sector JKL

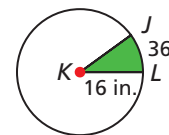

EXAMPLE 2 Agriculture Application

A circular plot with a 720 ft diameter is watered by a spray irrigation system. To the nearest square foot, what is the area that is watered as the sprinkler rotates through an angle of 50° ?



$$\begin{aligned} A &= \pi r^2 \left(\frac{m^\circ}{360^\circ} \right) \\ &= \pi (360)^2 \left(\frac{50^\circ}{360^\circ} \right) \quad d = 720 \text{ ft}, r = 360 \text{ ft.} \\ &\approx 56,549 \text{ ft}^2 \quad \text{Simplify.} \end{aligned}$$



2. To the nearest square foot, what is the area watered in Example 2 as the sprinkler rotates through a semicircle?

A **segment of a circle** is a region bounded by an arc and its chord. The shaded region in the figure is a segment.

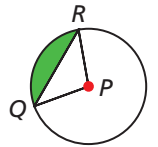

Area of a Segment

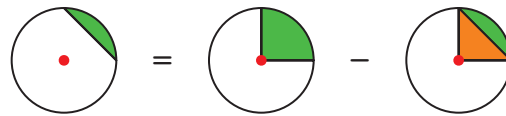

area of segment = area of sector – area of triangle

EXAMPLE 3 Finding the Area of a Segment

Find the area of segment ACB to the nearest hundredth.

Step 1 Find the area of sector ACB .

$$\begin{aligned} A &= \pi r^2 \left(\frac{m^\circ}{360^\circ} \right) \quad \text{Use formula for area of a sector.} \\ &= \pi (12)^2 \left(\frac{60^\circ}{360^\circ} \right) \quad \text{Substitute 12 for } r \text{ and } 60 \text{ for } m. \\ &= 24\pi \text{ in}^2 \end{aligned}$$

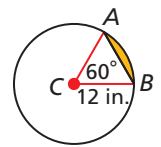

Remember!

In a 30° - 60° - 90° triangle, the length of the leg opposite the 60° angle is $\sqrt{3}$ times the length of the shorter leg.

Step 2 Find the area of $\triangle ACB$.

Draw altitude \overline{AD} .

$$\begin{aligned} A &= \frac{1}{2}bh = \frac{1}{2}(12)(6\sqrt{3}) \quad CD = 6 \text{ in.}, \text{ and } h = 6\sqrt{3} \text{ in.} \\ &= 36\sqrt{3} \text{ in}^2 \quad \text{Simplify.} \end{aligned}$$

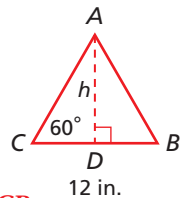

$$\begin{aligned} \text{Step 3 area of segment} &= \text{area of sector } ACB - \text{area of } \triangle ACB \\ &= 24\pi - 36\sqrt{3} \\ &\approx 13.04 \text{ in}^2 \end{aligned}$$



3. Find the area of segment RST to the nearest hundredth.

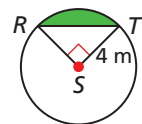

In the same way that the area of a sector is a fraction of the area of the circle, the length of an arc is a fraction of the circumference of the circle.



Arc Length

TERM	DIAGRAM	LENGTH
Arc length is the distance along an arc measured in linear units.		$L = 2\pi r \left(\frac{m^\circ}{360^\circ} \right)$

EXAMPLE 4 Finding Arc Length

Find each arc length. Give your answer in terms of π and rounded to the nearest hundredth.

A \widehat{CD}

$$L = 2\pi r \left(\frac{m^\circ}{360^\circ} \right)$$

Use formula for arc length.

$$= 2\pi(10) \left(\frac{90^\circ}{360^\circ} \right)$$

Substitute 10 for r and 90 for m .

$$= 5\pi \text{ ft} \approx 15.71 \text{ ft}$$

Simplify.

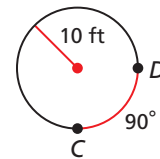

B an arc with measure 35° in a circle with radius 3 in.

$$L = 2\pi r \left(\frac{m^\circ}{360^\circ} \right)$$

Use formula for arc length.

$$= 2\pi(3) \left(\frac{35^\circ}{360^\circ} \right)$$

Substitute 3 for r and 35 for m .

$$= \frac{7}{12} \text{ in.} \approx 1.83 \text{ in.}$$

Simplify.



Find each arc length. Give your answer in terms of π and rounded to the nearest hundredth.

4a. \widehat{GH}

4b. an arc with measure 135° in a circle with radius 4 cm

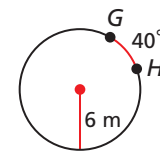

THINK AND DISCUSS

- What is the difference between arc measure and arc length?
- A slice of pizza is a sector of a circle. Explain what measurements you would need to make in order to calculate the area of the slice.
- GET ORGANIZED** Copy and complete the graphic organizer.



	Formula	Diagram
Area of a Sector		
Area of a Segment		
Arc Length		



GUIDED PRACTICE

1. **Vocabulary** In a circle, the region bounded by a chord and an arc is called a . (*sector or segment*)

SEE EXAMPLE 1

p. 764

Find the area of each sector. Give your answer in terms of π and rounded to the nearest hundredth.

2. sector PQR

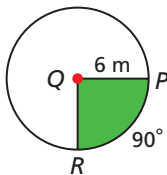

3. sector JKL

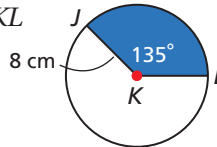

4. sector ABC

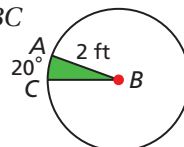

SEE EXAMPLE 2

p. 765

5. **Navigation** The beam from a lighthouse is visible for a distance of 3 mi. To the nearest square mile, what is the area covered by the beam as it sweeps in an arc of 150° ?

SEE EXAMPLE 3

p. 765

6. **Multi-Step** Find the area of each segment to the nearest hundredth.

6.

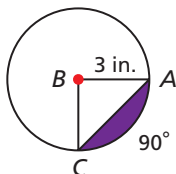

7.

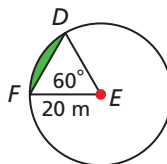

8.

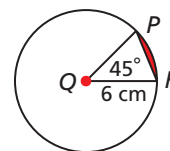

SEE EXAMPLE 4

p. 766

Find each arc length. Give your answer in terms of π and rounded to the nearest hundredth.

9. \widehat{EF}

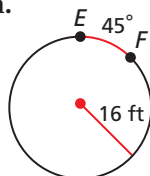

10. \widehat{PQ}

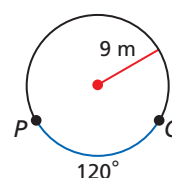

11. an arc with measure 20° in a circle with radius 6 in.

PRACTICE AND PROBLEM SOLVING

Independent Practice

For Exercises	See Example
12–14	1
15	2
16–18	3
19–21	4

Find the area of each sector. Give your answer in terms of π and rounded to the nearest hundredth.

12. sector DEF

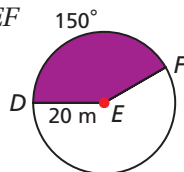

13. sector GHJ

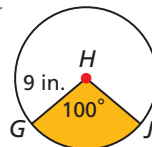

14. sector RST

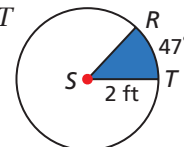

Extra Practice

Skills Practice p. S24

Application Practice p. S38

15. **Architecture** A *lunette* is a semicircular window that is sometimes placed above a doorway or above a rectangular window. To the nearest square inch, what is the area of the lunette?

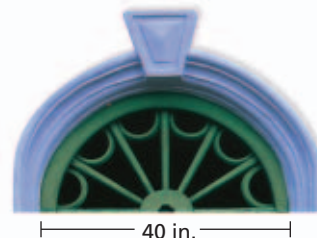

Multi-Step Find the area of each segment to the nearest hundredth.

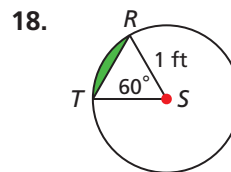
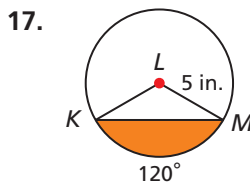
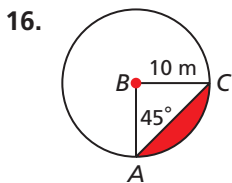

Find each arc length. Give your answer in terms of π and rounded to the nearest hundredth.

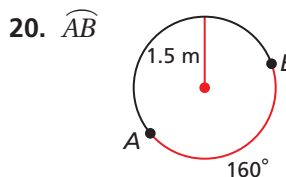
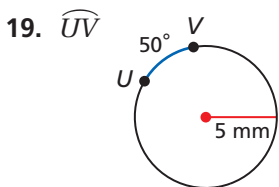

21. an arc with measure 9° in a circle with diameter 4 ft

22. **Math History** Greek mathematicians studied the *salinon*, a figure bounded by four semicircles. What is the perimeter of this salinon to the nearest tenth of an inch?

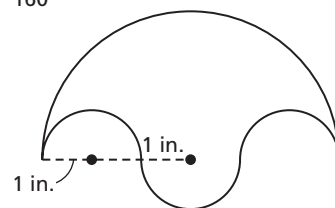

Tell whether each statement is sometimes, always, or never true.

23. The length of an arc of a circle is greater than the circumference of the circle.
 24. Two arcs with the same measure have the same arc length.
 25. In a circle, two arcs with the same length have the same measure.

Find the radius of each circle.

26. area of sector $ABC = 9\pi$

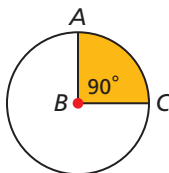

27. arc length of $\widehat{EF} = 8\pi$

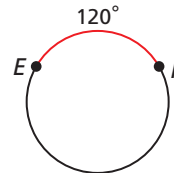

28. **Estimation** The fraction $\frac{22}{7}$ is an approximation for π .

- a. Use this value to estimate the arc length of \widehat{XY} .
 b. Use the π key on your calculator to find the length of \widehat{XY} to 8 decimal places.
 c. Was your estimate in part a an overestimate or an underestimate?

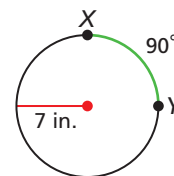

Math History



Hypatia lived 1600 years ago. She is considered one of history's most important mathematicians. She is credited with contributions to both geometry and astronomy.

CONCEPT CONNECTION



29. This problem will prepare you for the Concept Connection on page 770.
 The pedals of a penny-farthing bicycle are directly connected to the front wheel.
- a. Suppose a penny-farthing bicycle has a front wheel with a diameter of 5 ft. To the nearest tenth of a foot, how far does the bike move when you turn the pedals through an angle of 90° ?
- b. Through what angle should you turn the pedals in order to move forward by a distance of 4.5 ft? Round to the nearest degree.



30. **Critical Thinking** What is the length of the radius that makes the area of $\odot A = 24 \text{ in}^2$ and the area of sector $BAC = 3 \text{ in}^2$? Explain.
31. **Write About It** Given the length of an arc of a circle and the measure of the arc, explain how to find the radius of the circle.

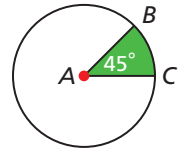

32. What is the area of sector AOB ?
 (A) 4π (B) 16π (C) 32π (D) 64π
33. What is the length of \widehat{AB} ?
 (F) 2π (G) 4π (H) 8π (J) 16π
34. **Gridded Response** To the nearest hundredth, what is the area of the sector determined by an arc with measure 35° in a circle with radius 12?

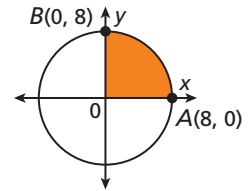

CHALLENGE AND EXTEND

35. In the diagram, the larger of the two concentric circles has radius 5, and the smaller circle has radius 2. What is the area of the shaded region in terms of π ?
36. A wedge of cheese is a sector of a cylinder.
 a. To the nearest tenth, what is the volume of the wedge with the dimensions shown?
 b. What is the surface area of the wedge of cheese to the nearest tenth?
37. **Probability** The central angles of a target measure 45° . The inner circle has a radius of 1 ft, and the outer circle has a radius of 2 ft. Assuming that all arrows hit the target at random, find the following probabilities.
 a. hitting a red region
 b. hitting a blue region
 c. hitting a red or blue region

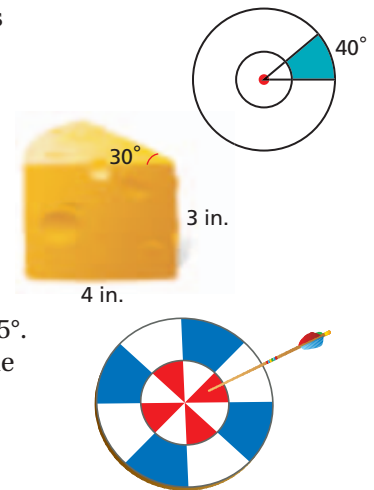

SPIRAL REVIEW

Determine whether each line is parallel to $y = 4x - 5$, perpendicular to $y = 4x - 5$, or neither. (*Previous course*)

38. $8x - 2y = 6$
 39. line passing through the points $(\frac{1}{2}, 0)$ and $(1\frac{1}{2}, 2)$
 40. line with x -intercept 4 and y -intercept 1

Find each measurement. Give your answer in terms of π . (*Lesson 10-8*)

41. volume of a sphere with radius 3 cm
 42. circumference of a great circle of a sphere whose surface area is $4\pi \text{ cm}^2$

Find the indicated measure. (*Lesson 11-2*)

43. $m\angle KLJ$ 44. $m\widehat{KJ}$ 45. $m\widehat{JFH}$

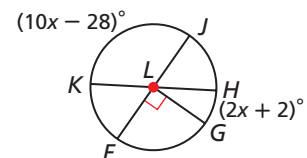

CONCEPT CONNECTION



Lines and Arcs in Circles

As the Wheels Turn The bicycle was invented in the 1790s. The first models didn't even have pedals—riders moved forward by pushing their feet along the ground! Today the bicycle is a high-tech machine that can include hydraulic brakes and electronic gear changers.

1. A road race bicycle wheel is 28 inches in diameter. A manufacturer makes metal bicycle stands that are 10 in. tall. How long should a stand be to the nearest tenth in order to support a 28 in. wheel? (*Hint:* Consider the triangle formed by the radii and the top of the stand.)

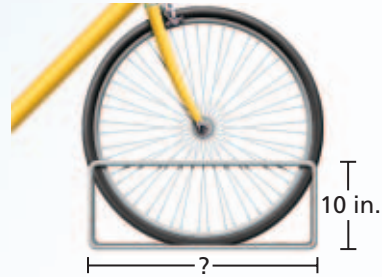

2. The chain of a bicycle loops around a large gear connected to the bike's pedals and a small gear attached to the rear wheel. In the diagram, the distance AB between the centers of the gears the nearest tenth is 15 in. Find CD , the length of the chain between the two gears to the nearest tenth. (*Hint:* Draw a segment from B to AD that is parallel to CD .)

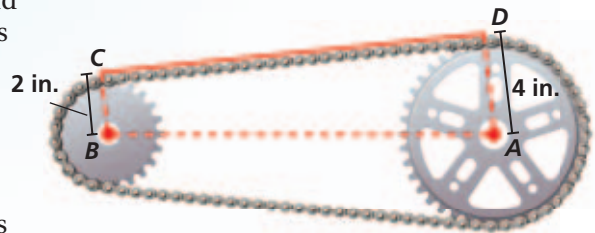

3. By pedaling, you turn the large gear through an angle of 60° . How far does the chain move around the circumference of the gear to the nearest tenth?
4. As the chain moves, it turns the small gear. If you use the distance you calculated in Problem 3, through what angle does the small gear turn to the nearest degree?



Quiz for Lessons 11-1 Through 11-3

11-1 Lines That Intersect Circles

Identify each line or segment that intersects each circle.

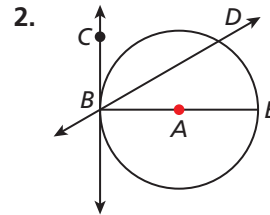
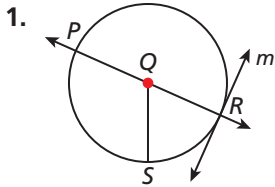

3. The tallest building in Africa is the Carlton Centre in Johannesburg, South Africa. What is the distance from the top of this 732 ft building to the horizon to the nearest mile? (*Hint:* 5280 ft = 1 mi; radius of Earth = 4000 mi)

11-2 Arcs and Chords

Find each measure.

4. \widehat{BC}
5. \widehat{BED}

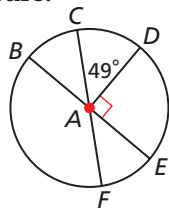

6. \widehat{SR}
7. \widehat{SQU}

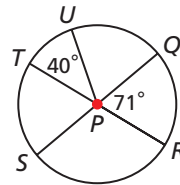

Find each length to the nearest tenth.

8. JK

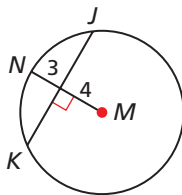

9. XY

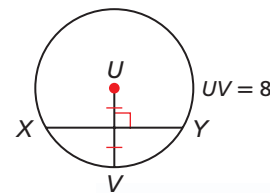

11-3 Sector Area and Arc Length

10. As part of an art project, Peter buys a circular piece of fabric and then cuts out the sector shown. What is the area of the sector to the nearest square centimeter?

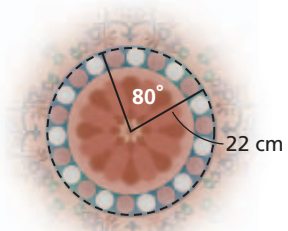

Find each arc length. Give your answer in terms of π and rounded to the nearest hundredth.

11. \widehat{AB}

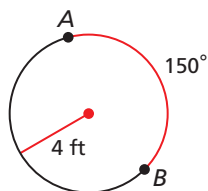

12. \widehat{EF}

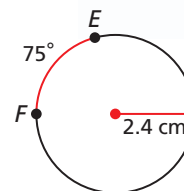

13. an arc with measure 44° in a circle with diameter 10 in.
14. a semicircle in a circle with diameter 92 m

11-4

Inscribed Angles



Objectives

Find the measure of an inscribed angle.

Use inscribed angles and their properties to solve problems.

Vocabulary

inscribed angle
intercepted arc
subtend

California Standards

7.0 Students prove and use theorems involving the properties of parallel lines cut by a transversal, the properties of quadrilaterals, and the properties of circles.

21.0 Students prove and solve problems regarding relationships among chords, secants, tangents, inscribed angles, and inscribed and circumscribed polygons of circles.

Also covered: **16.0**

Why learn this?

You can use inscribed angles to find measures of angles in string art. (See Example 2.)

String art often begins with pins or nails that are placed around the circumference of a circle. A long piece of string is then wound from one nail to another. The resulting pattern may include hundreds of *inscribed angles*.

An **inscribed angle** is an angle whose vertex is on a circle and whose sides contain chords of the circle. An **intercepted arc** consists of endpoints that lie on the sides of an inscribed angle and all the points of the circle between them. A chord or arc **subtends** an angle if its endpoints lie on the sides of the angle.

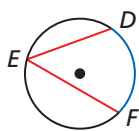

$\angle DEF$ is an **inscribed angle**.

\widehat{DF} is the **intercepted arc**.

\widehat{DF} subtends $\angle DEF$.



Theorem 11-4-1 Inscribed Angle Theorem

The measure of an inscribed angle is half the measure of its intercepted arc.

$$m\angle ABC = \frac{1}{2}m\widehat{AC}$$

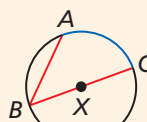

Case 1

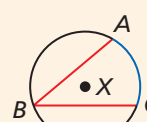

Case 2

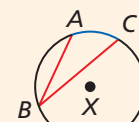

Case 3

You will prove Cases 2 and 3 of Theorem 11-4-1 in Exercises 30 and 31.

PROOF

Inscribed Angle Theorem

Given: $\angle ABC$ is inscribed in $\odot X$.

Prove: $m\angle ABC = \frac{1}{2}m\widehat{AC}$

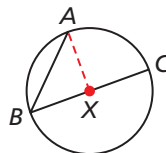

Proof Case 1:

$\angle ABC$ is inscribed in $\odot X$ with X on \widehat{BC} . Draw \overline{XA} . $m\widehat{AC} = m\angle AXC$.

By the Exterior Angle Theorem $m\angle AXC = m\angle ABX + m\angle BAX$.

Since \overline{XA} and \overline{XB} are radii of the circle, $\overline{XA} \cong \overline{XB}$. Then by definition $\triangle AXB$ is isosceles. Thus $m\angle ABX = m\angle BAX$.

By the Substitution Property, $m\widehat{AC} = 2m\angle ABX$ or $2m\angle ABC$.

Thus $\frac{1}{2}m\widehat{AC} = m\angle ABC$.

EXAMPLE 1 Finding Measures of Arcs and Inscribed Angles

Find each measure.

A $m\angle RST$

$$\begin{aligned} m\angle RST &= \frac{1}{2}m\widehat{RT} && \text{Inscribed } \angle \text{ Thm.} \\ &= \frac{1}{2}(120^\circ) = 60^\circ && \text{Substitute 120 for } m\widehat{RT}. \end{aligned}$$

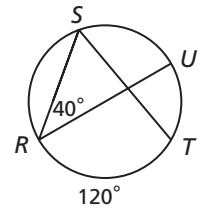

B $m\widehat{SU}$

$$\begin{aligned} m\angle SRU &= \frac{1}{2}m\widehat{SU} && \text{Inscribed } \angle \text{ Thm.} \\ 40^\circ &= \frac{1}{2}m\widehat{SU} && \text{Substitute 40 for } m\angle SRU. \\ m\widehat{SU} &= 80^\circ && \text{Mult. both sides by 2.} \end{aligned}$$



Find each measure.

- 1a. $m\widehat{ADC}$
1b. $m\angle DAE$

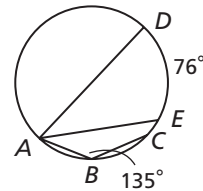

Corollary 11-4-2

COROLLARY	HYPOTHESIS	CONCLUSION
If inscribed angles of a circle intercept the same arc or are subtended by the same chord or arc, then the angles are congruent.	<p>$\angle ACB$, $\angle ADB$, and $\angle AEB$ intercept \widehat{AB}.</p>	$\angle ACB \cong \angle ADB \cong \angle AEB$ (and $\angle CAE \cong \angle CBE$)

You will prove Corollary 11-4-2 in Exercise 32.

EXAMPLE 2 Hobby Application

Find $m\angle DEC$, if $m\widehat{AD} = 86^\circ$.

$$\begin{aligned} \angle BAC &\cong \angle BDC && \angle BAC \text{ and } \angle BDC \text{ intercept } \widehat{BC}. \\ m\angle BAC &= m\angle BDC && \text{Def. of } \cong \\ m\angle BDC &= 60^\circ && \text{Substitute 60 for } m\angle BDC. \\ m\angle ACD &= \frac{1}{2}m\widehat{AD} && \text{Inscribed } \angle \text{ Thm.} \\ &= \frac{1}{2}(86^\circ) && \text{Substitute 86 for } m\widehat{AD}. \\ &= 43^\circ && \text{Simplify.} \\ m\angle DEC + 60 + 43 &= 180 && \triangle \text{ Sum Theorem} \\ m\angle DEC &= 77^\circ && \text{Simplify.} \end{aligned}$$

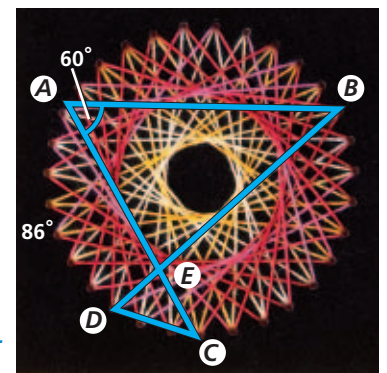

2. Find $m\angle ABD$ and $m\widehat{BC}$ in the string art.



Theorem 11-4-3

An inscribed angle subtends a semicircle if and only if the angle is a right angle.

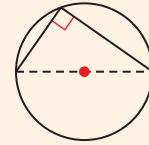

You will prove Theorem 11-4-3 in Exercise 43.

EXAMPLE 3 Finding Angle Measures in Inscribed Triangles



Find each value.

A x

$\angle RQT$ is a right angle

$$m\angle RQT = 90^\circ$$

$$4x + 6 = 90$$

$$4x = 84$$

$$x = 21$$

$\angle RQT$ is inscribed in a semicircle.

Def. of rt. \angle

Substitute $4x + 6$ for $m\angle RQT$.

Subtract 6 from both sides.

Divide both sides by 4.

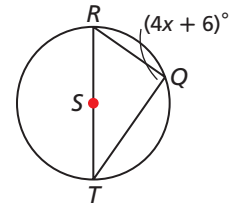

B $m\angle ADC$

$$m\angle ABC = m\angle ADC$$

$$10y - 28 = 7y - 1$$

$$3y - 28 = -1$$

$$3y = 27$$

$$y = 9$$

$$m\angle ADC = 7(9) - 1 = 62^\circ$$

$\angle ABC$ and $\angle ADC$ both intercept \widehat{AC} .

Substitute the given values.

Subtract $7y$ from both sides.

Add 28 to both sides.

Divide both sides by 3.

Substitute 9 for y .

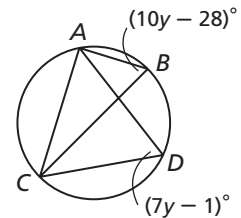

Find each value.

3a. z

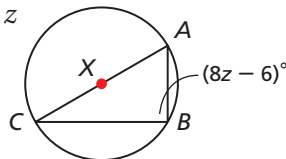

3b. $m\angle EDF$

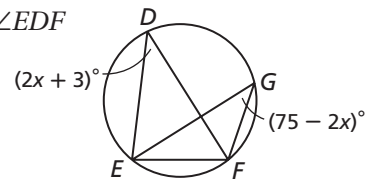

Construction Center of a Circle

1

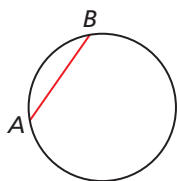

Draw a circle and chord \overline{AB} .

2

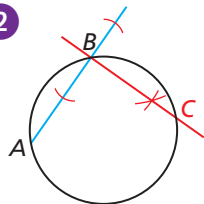

Construct a line perpendicular to \overline{AB} at B . Where the line and the circle intersect, label the point C .

3

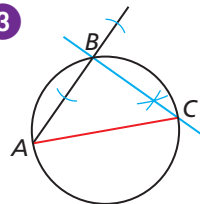

Draw chord \overline{AC} .

4

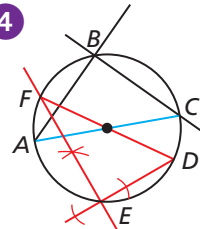

Repeat steps to draw chords \overline{DE} and \overline{DF} . The intersection of \overline{AC} and \overline{DF} is the center of the circle.

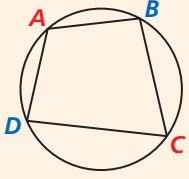

Theorem 11-4-4

THEOREM	HYPOTHESIS	CONCLUSION
If a quadrilateral is inscribed in a circle, then its opposite angles are supplementary.	 ABCD is inscribed in $\odot E$.	$\angle A$ and $\angle C$ are supplementary. $\angle B$ and $\angle D$ are supplementary.

You will prove Theorem 11-4-4 in Exercise 44.

EXAMPLE 4 Finding Angle Measures in Inscribed Quadrilaterals



Find the angle measures of PQRS.

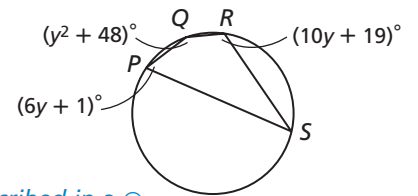

Step 1 Find the value of y .

$$m\angle P + m\angle R = 180^\circ \quad PQRS \text{ is inscribed in a } \odot.$$

$$6y + 1 + 10y + 19 = 180 \quad \text{Substitute the given values.}$$

$$16y + 20 = 180 \quad \text{Simplify.}$$

$$16y = 160 \quad \text{Subtract 20 from both sides.}$$

$$y = 10 \quad \text{Divide both sides by 16.}$$

Step 2 Find the measure of each angle.

$$m\angle P = 6(10) + 1 = 61^\circ \quad \text{Substitute 10 for } y \text{ in each expression.}$$

$$m\angle R = 10(10) + 19 = 119^\circ$$

$$m\angle Q = 10^2 + 48 = 148^\circ$$

$$m\angle Q + m\angle S = 180^\circ \quad \angle Q \text{ and } \angle S \text{ are supp.}$$

$$148^\circ + m\angle S = 180^\circ \quad \text{Substitute 148 for } m\angle Q.$$

$$m\angle S = 32^\circ \quad \text{Subtract 148 from both sides.}$$



4. Find the angle measures of JKLM.

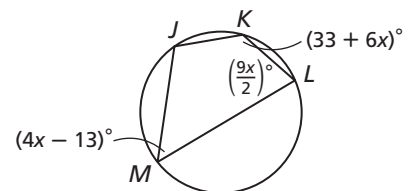

THINK AND DISCUSS

1. Can $\square ABCD$ be inscribed in a circle? Why or why not?

2. An inscribed angle intercepts an arc that is $\frac{1}{4}$ of the circle. Explain how to find the measure of the inscribed angle.

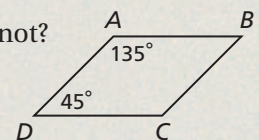

3. **GET ORGANIZED** Copy and complete the graphic organizer. In each box write a definition, properties, an example, and a nonexample.

Definition	Properties
Inscribed Angles	
Example	Nonexample



GUIDED PRACTICE

1. **Vocabulary** $A, B,$ and C lie on $\odot P$. $\angle ABC$ is an example of an angle. (*intercepted* or *inscribed*)

SEE EXAMPLE 1

p. 773

Find each measure.

- 2. $m\angle DEF$
- 3. $m\widehat{EG}$

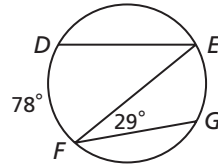

4. $m\widehat{JKL}$

5. $m\angle LKM$

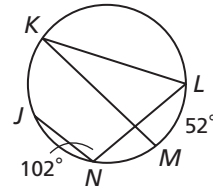

SEE EXAMPLE 2

p. 773

6. **Crafts** A circular loom can be used for knitting. What is the $m\angle QTR$ in the knitting loom?

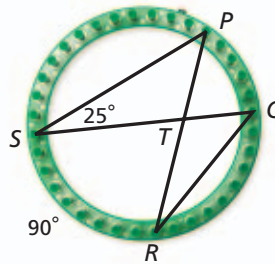

SEE EXAMPLE 3

p. 774

Find each value.

7. x

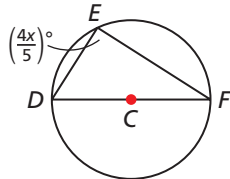

8. y

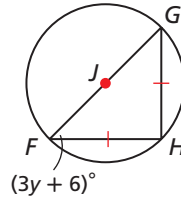

9. $m\angle XYZ$

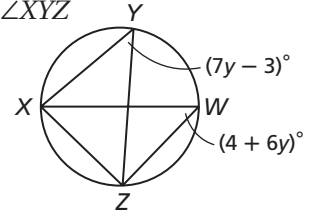

SEE EXAMPLE 4

p. 775

Multi-Step Find the angle measures of each quadrilateral.

10. $PQRS$

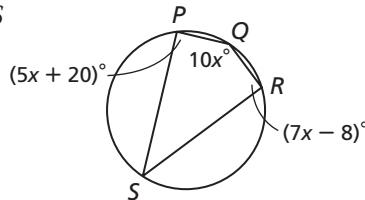

11. $ABCD$

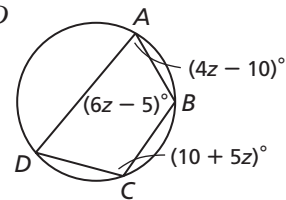

PRACTICE AND PROBLEM SOLVING

Independent Practice

For Exercises	See Example
12–15	1
16	2
17–20	3
21–22	4

Find each measure.

12. $m\widehat{ML}$

13. $m\angle KMN$

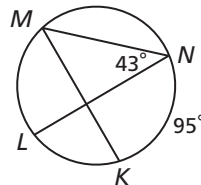

14. $m\widehat{EGH}$

15. $m\angle GFH$

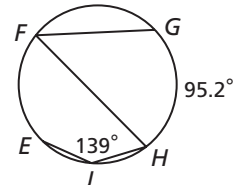

16. **Crafts** An artist created a stained glass window. If $m\angle BEC = 40^\circ$ and $m\widehat{AB} = 44^\circ$, what is $m\angle ADC$?



Extra Practice

Skills Practice p. S25
Application Practice p. S38



Algebra Find each value.

17. y

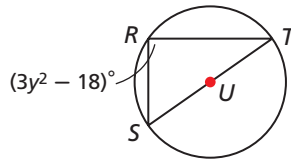

18. z

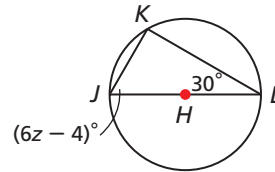

19. $m\widehat{AB}$

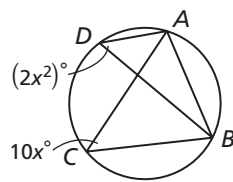

20. $m\angle MPN$

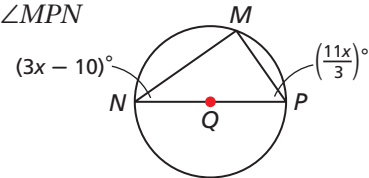

Multi-Step Find the angle measures of each quadrilateral.

21. $BCDE$

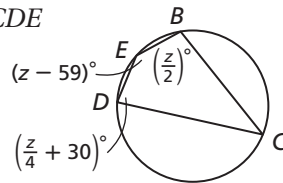

22. $TUVW$

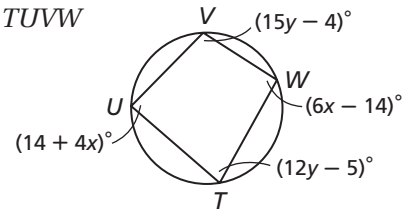

Tell whether each statement is sometimes, always, or never true.

23. Two inscribed angles that intercept the same arc of a circle are congruent.
24. When a right triangle is inscribed in a circle, one of the legs of the triangle is a diameter of the circle.
25. A trapezoid can be inscribed in a circle.

Multi-Step Find each angle measure.

26. $m\angle ABC$ if
 $m\angle ADC = 112^\circ$

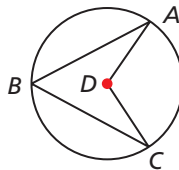

27. $m\angle PQR$ if
 $m\widehat{PQR} = 130^\circ$

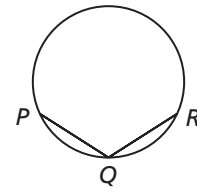

28. Prove that the measure of a central angle subtended by a chord is twice the measure of the inscribed angle subtended by the chord.

Given: In $\odot H$ \widehat{JK} subtends $\angle JHK$ and $\angle JLK$.

Prove: $m\angle JHK = 2m\angle JLK$

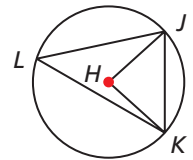

CONCEPT CONNECTION



29. This problem will prepare you for the Concept Connection on page 806.

A Native American sand painting could be used to indicate the direction of sunrise on the winter and summer solstices. You can make this design by placing six equally spaced points around the circumference of a circle and connecting them as shown.

- Find $m\angle BAC$.
- Find $m\angle CDE$.
- What type of triangle is $\triangle FBC$? Why?

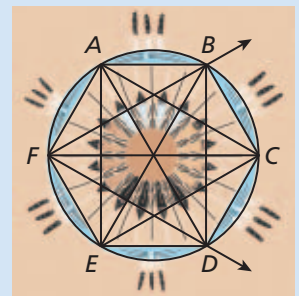

30. **Given:** $\angle ABC$ is inscribed in $\odot X$ with X in the interior of $\angle ABC$.
Prove: $m\angle ABC = \frac{1}{2}m\widehat{AC}$
(Hint: Draw \overrightarrow{BX} and use Case 1 of the Inscribed Angle Theorem.)

31. **Given:** $\angle ABC$ is inscribed in $\odot X$ with X in the exterior of $\angle ABC$.
Prove: $m\angle ABC = \frac{1}{2}m\widehat{AC}$

32. Prove Corollary 11-4-2.
Given: $\angle ACB$ and $\angle ADB$ intercept \widehat{AB} .
Prove: $\angle ACB \cong \angle ADB$

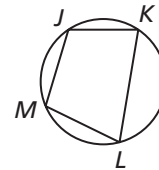
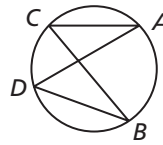

33. **Multi-Step** In the diagram, $m\widehat{JKL} = 198^\circ$, and $m\widehat{KLM} = 216^\circ$. Find the measures of the angles of quadrilateral $JKLM$.

34. **Critical Thinking** A rectangle $PQRS$ is inscribed in a circle. What can you conclude about \overline{PR} ? Explain.

35. **History** The diagram shows the Winchester Round Table with inscribed $\triangle ABC$. The table may have been made at the request of King Edward III, who created the Order of Garter as a return to the Round Table and an order of chivalry.

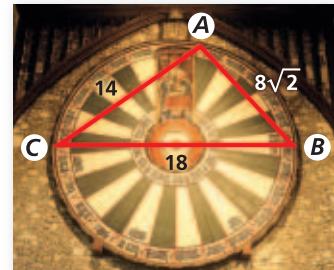

- a. Explain why \overline{BC} must be a diameter of the circle.
b. Find $m\widehat{AC}$.

36. To inscribe an equilateral triangle in a circle, draw a diameter \overline{BC} . Open the compass to the radius of the circle. Place the point of the compass at C and make arcs on the circle at D and E , as shown. Draw \overline{BD} , \overline{BE} , and \overline{DE} . Explain why $\triangle BDE$ is an equilateral triangle.

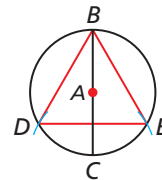

37. **Write About It** A student claimed that if a parallelogram contains a 30° angle, it cannot be inscribed in a circle. Do you agree or disagree? Explain.

38. **Construction** Circumscribe a circle about a triangle. (*Hint: Follow the steps for the construction of a circle through three given noncollinear points.*)



39. What is $m\angle BAC$?

- (A) 38° (C) 66°
(B) 43° (D) 81°

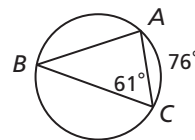

40. Equilateral $\triangle XCZ$ is inscribed in a circle. If \overline{CY} bisects $\angle C$, what is $m\widehat{XY}$?

- (F) 15° (G) 30° (H) 60° (J) 120°

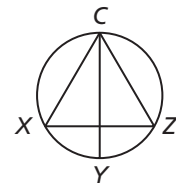

41. Quadrilateral $ABCD$ is inscribed in a circle. The ratio of $m\angle A$ to $m\angle C$ is 4:5. What is $m\angle A$?

- (A) 20° (B) 40° (C) 80° (D) 100°

42. Which of these angles has the greatest measure?

- (F) $\angle STR$ (G) $\angle QPR$ (H) $\angle QSR$ (J) $\angle PQS$



History

The Winchester Round Table, probably built in the late thirteenth century, is 18 ft across and weighs 1.25 tons. King Arthur's Round Table of English legend would have been much larger—it could seat 1600 men.

CHALLENGE AND EXTEND

43. Prove that an inscribed angle subtends a semicircle if and only if the angle is a right angle. (*Hint:* There are two parts.)
44. Prove that if a quadrilateral is inscribed in a circle, then its opposite angles are supplementary. (*Hint:* There are two parts.)
45. Find $m\widehat{PQ}$ to the nearest degree.

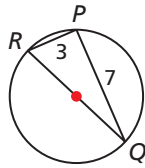

46. Find $m\angle ABD$.

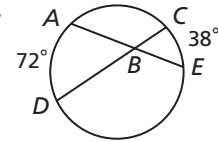

47. **Construction** To circumscribe an equilateral triangle about a circle, construct \overline{AB} parallel to the horizontal diameter of the circle and tangent to the circle. Then use a $30^\circ\text{-}60^\circ\text{-}90^\circ$ triangle to draw \overline{AC} and \overline{BC} so that they form 60° angles with \overline{AB} and are tangent to the circle.

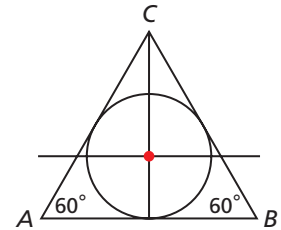

SPIRAL REVIEW

48. Tickets for a play cost \$15.00 for section C, \$22.50 for section B, and \$30.00 for section A. Amy spent a total of \$255.00 for 12 tickets. If she spent the same amount on section C tickets as section A tickets, how many tickets for section B did she purchase? (*Previous course*)

Write a ratio expressing the slope of the line through each pair of points. (*Lesson 7-1*)

49. $(4\frac{1}{2}, -6)$ and $(8, \frac{1}{2})$ 50. $(-9, -8)$ and $(0, -2)$ 51. $(3, -14)$ and $(11, 6)$

Find each of the following. (*Lesson 11-2*)

52. $m\widehat{ST}$

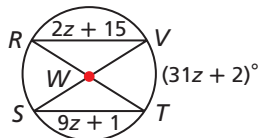

53. area of $\triangle ABD$

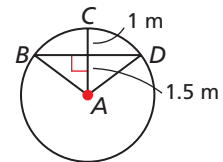

Construction Tangent to a Circle From an Exterior Point

1



Draw $\odot C$ and locate P in the exterior of the circle.

2

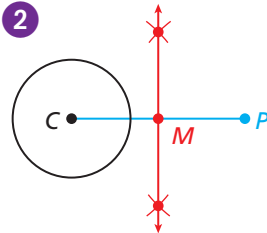

Draw \overline{CP} . Construct M , the midpoint of \overline{CP} .

3

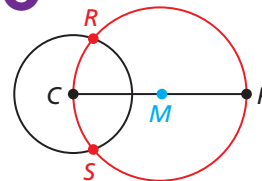

Center the compass at M . Draw a circle through C and P . It will intersect $\odot C$ at R and S .

4

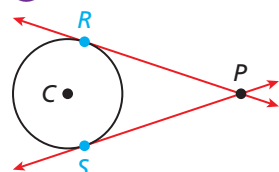

R and S are the tangent points. Draw \overrightarrow{PR} and \overrightarrow{PS} tangent to $\odot C$.

1. Can you draw $\overline{CR} \perp \overrightarrow{RP}$? Explain.

11-5 Technology LAB

Use with Lesson 11-5

Explore Angle Relationships in Circles

In Lesson 11-4, you learned that the measure of an angle inscribed in a circle is half the measure of its intercepted arc. Now you will explore other angles formed by pairs of lines that intersect circles.



California Standards

7.0 Students prove and use theorems involving the properties of parallel lines cut by a transversal, the properties of quadrilaterals, and the properties of circles.

21.0 Students prove and solve problems regarding relationships among chords, secants, tangents, inscribed angles, and inscribed and circumscribed polygons of circles.

Also covered: **1.0**

Activity 1

- 1 Create a circle with center A . Label the point on the circle as B . Create a radius segment from A to a new point C on the circle.
- 2 Construct a line through C perpendicular to radius \overline{AC} . Create a new point D on this line, which is tangent to circle A at C . Hide radius \overline{AC} .
- 3 Create a new point E on the circle and then construct secant \overline{CE} .
- 4 Measure $\angle DCE$ and measure \widehat{CBE} .
(Hint: To measure an arc in degrees, select the three points and the circle and then choose Arc Angle from the Measure menu.)
- 5 Drag E around the circle and examine the changes in the measures. Fill in the angle and arc measures in a chart like the one below. Try to create acute, right, and obtuse angles. Can you make a conjecture about the relationship between the angle measure and the arc measure?

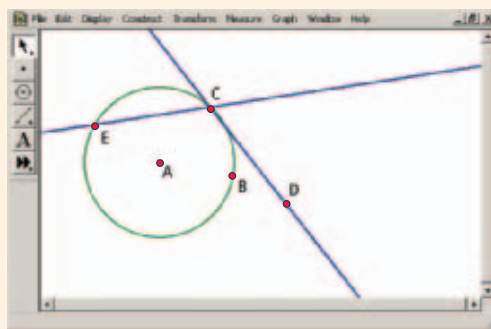

$m\angle DCE$					
$m\widehat{CBE}$					
Angle Type					

Activity 2

- 1 Construct a new circle with two secants \overleftrightarrow{CD} and \overleftrightarrow{EF} that intersect *inside* the circle at G .
- 2 Create two new points H and I that are on the circle as shown. These will be used to measure the arcs. Hide B if desired. (It controls the circle's size.)
- 3 Measure $\angle DGF$ formed by the secant lines and measure \widehat{CHE} and \widehat{DIF} .
- 4 Drag F around the circle and examine the changes in measures. Be sure to keep H between C and E and I between D and F for accurate arc measurement. Move them if needed.

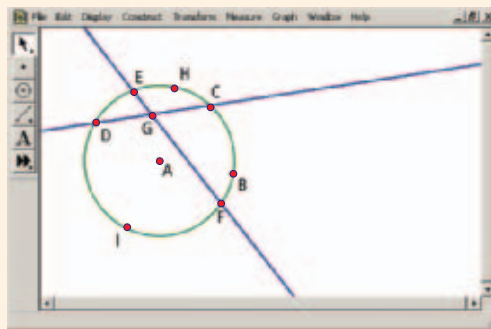

- 5 Fill in the angle and arc measures in a chart like the one below. Try to create acute, right, and obtuse angles. Can you make a conjecture about the relationship between the angle measure and the two arc measures?

$m\angle DGF$					
$m\widehat{CHE}$					
$m\widehat{DIF}$					
Sum of Arcs					

Activity 3

- Use the same figure from Activity 2. Drag points around the circle so that the intersection G is now *outside* the circle. Move H so it is between E and D and I is between C and F , as shown.
- Measure $\angle FGC$ formed by the secant lines and measure \widehat{CIF} and \widehat{DHE} .
- Drag points around the circle and examine the changes in measures. Fill in the angle and arc measures in a chart like the one below. Can you make a conjecture about the relationship between the angle measure and the two arc measures?

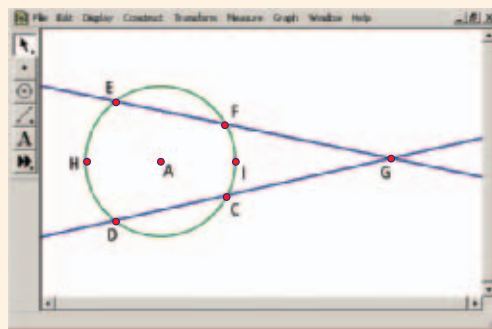

$m\angle FGC$					
$m\widehat{CIF}$					
$m\widehat{DHE}$					
Number of Arcs					

Try This

- How does the relationship you observed in Activity 1 compare to the relationship between an inscribed angle and its intercepted arc?
- Why do you think the radius \overline{AC} is needed in Activity 1 for the construction of the tangent line? What theorem explains this?
- In Activity 3, try dragging points so that the secants become tangents. What conclusion can you make about the angle and arc measures?
- Examine the conjectures and theorems about the relationships between angles and arcs in a circle. What is true of an angle with a vertex *on* the circle? What is true of an angle with a vertex *inside* the circle? What is true of an angle with a vertex *outside* the circle? Summarize your findings.
- Does using geometry software to compare angle and arc measures constitute a formal proof of the relationship observed?

11-5

Angle Relationships in Circles



Objectives

Find the measures of angles formed by lines that intersect circles.

Use angle measures to solve problems.

Who uses this?

Circles and angles help optometrists correct vision problems. (See Example 4.)

Theorem 11-5-1 connects arc measures and the measures of tangent-secant angles with tangent-chord angles.



Theorem 11-5-1

THEOREM	HYPOTHESIS	CONCLUSION
If a tangent and a secant (or chord) intersect on a circle at the point of tangency, then the measure of the angle formed is half the measure of its intercepted arc.	<p>Tangent \overrightarrow{BC} and secant \overrightarrow{BA} intersect at B.</p>	$m\angle ABC = \frac{1}{2}m\widehat{AB}$

You will prove Theorem 11-5-1 in Exercise 45.

EXAMPLE 1 Using Tangent-Secant and Tangent-Chord Angles

California Standards

7.0 Students prove and use theorems involving the properties of parallel lines cut by a transversal, the properties of quadrilaterals, and the properties of circles.

21.0 Students prove and solve problems regarding relationships among chords, secants, tangents, inscribed angles, and inscribed and circumscribed polygons of circles.

Find each measure.

A $m\angle BCD$

$$m\angle BCD = \frac{1}{2}m\widehat{BC}$$

$$m\angle BCD = \frac{1}{2}(142^\circ)$$

$$= 71^\circ$$

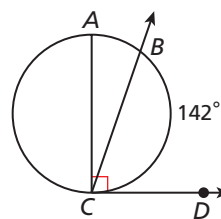

B $m\widehat{ABC}$

$$m\angle ACD = \frac{1}{2}m\widehat{ABC}$$

$$90^\circ = \frac{1}{2}m\widehat{ABC}$$

$$180^\circ = m\widehat{ABC}$$



Find each measure.

- $m\angle STU$
- $m\widehat{SR}$

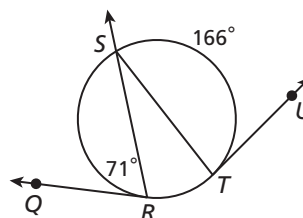

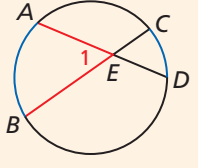

Theorem 11-5-2

THEOREM	HYPOTHESIS	CONCLUSION
If two secants or chords intersect in the interior of a circle, then the measure of each angle formed is half the sum of the measures of its intercepted arcs.	 Chords \overline{AD} and \overline{BC} intersect at E .	$m\angle 1 = \frac{1}{2}(m\widehat{AB} + m\widehat{CD})$

PROOF

Theorem 11-5-2

Given: \overline{AD} and \overline{BC} intersect at E .

Prove: $m\angle 1 = \frac{1}{2}(m\widehat{AB} + m\widehat{CD})$

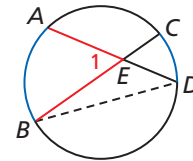

Proof:

Statements	Reasons
1. \overline{AD} and \overline{BC} intersect at E .	1. Given
2. Draw \overline{BD} .	2. Two pts. determine a line.
3. $m\angle 1 = m\angle EDB + m\angle EBD$	3. Ext. \angle Thm.
4. $m\angle EDB = \frac{1}{2}m\widehat{AB}$, $m\angle EBD = \frac{1}{2}m\widehat{CD}$	4. Inscribed \angle Thm.
5. $m\angle 1 = \frac{1}{2}m\widehat{AB} + \frac{1}{2}m\widehat{CD}$	5. Subst.
6. $m\angle 1 = \frac{1}{2}(m\widehat{AB} + m\widehat{CD})$	6. Distrib. Prop.

EXAMPLE 2 Finding Angle Measures Inside a Circle

Find each angle measure.

$$\begin{aligned}
 m\angle SQR &= \frac{1}{2}(m\widehat{PT} + m\widehat{SR}) \\
 &= \frac{1}{2}(32^\circ + 100^\circ) \\
 &= \frac{1}{2}(132^\circ) \\
 &= 66^\circ
 \end{aligned}$$

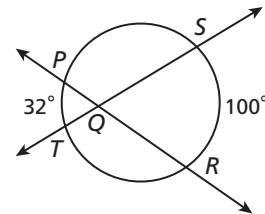

Find each angle measure.

2a. $m\angle ABD$

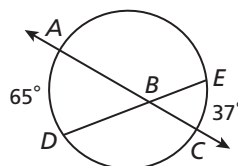

2b. $m\angle RNM$

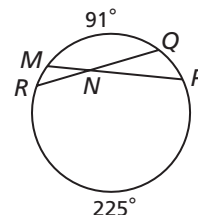



Theorem 11-5-3

If a **tangent and a secant**, **two tangents**, or **two secants** intersect in the exterior of a circle, then the measure of the angle formed is half the difference of the measures of its intercepted arcs.

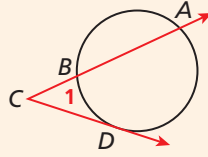

$$m\angle 1 = \frac{1}{2}(m\widehat{AD} - m\widehat{BD})$$

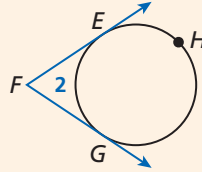

$$m\angle 2 = \frac{1}{2}(m\widehat{EHG} - m\widehat{EG})$$

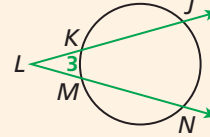

$$m\angle 3 = \frac{1}{2}(m\widehat{JN} - m\widehat{KM})$$

You will prove Theorem 11-5-3 in Exercises 34–36.

EXAMPLE 3 Finding Measures Using Tangents and Secants

Find the value of x .

A

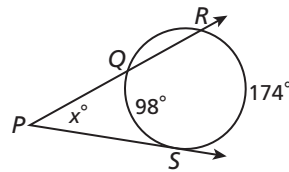

$$\begin{aligned} x &= \frac{1}{2}(m\widehat{RS} - m\widehat{QS}) \\ &= \frac{1}{2}(174^\circ - 98^\circ) \\ &= 38^\circ \end{aligned}$$

B

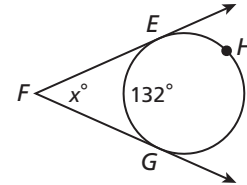

$$\begin{aligned} x &= \frac{1}{2}(m\widehat{EHG} - m\widehat{EG}) \\ &= \frac{1}{2}(228^\circ - 132^\circ) \\ &= 48^\circ \end{aligned}$$

Helpful Hint

\widehat{EHG} and \widehat{EG} joined together make a whole circle. So $m\widehat{EHG} = 360^\circ - 132^\circ = 228^\circ$



3. Find the value of x .

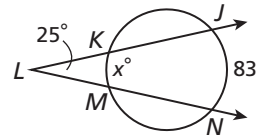

EXAMPLE 4 Biology Application

When a person is farsighted, light rays enter the eye and are focused behind the retina. In the eye shown, light rays converge at R . If $m\widehat{PS} = 60^\circ$ and $m\widehat{QT} = 14^\circ$, what is $m\angle PRS$?

$$\begin{aligned} m\angle PRS &= \frac{1}{2}(m\widehat{PS} - m\widehat{QT}) \\ &= \frac{1}{2}(60^\circ - 14^\circ) \\ &= \frac{1}{2}(46^\circ) = 23^\circ \end{aligned}$$

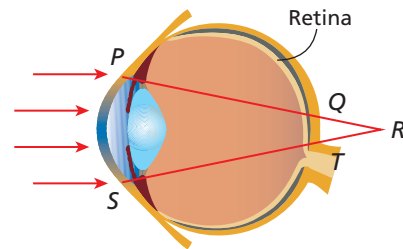

4. Two of the six muscles that control eye movement are attached to the eyeball and intersect behind the eye. If $m\widehat{AEB} = 225^\circ$, what is $m\angle ACB$?

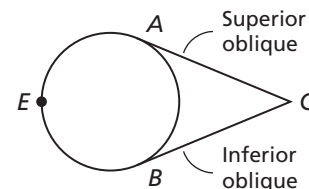

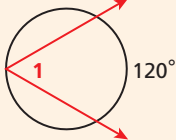
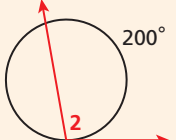
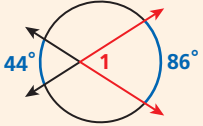
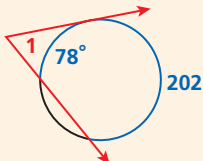
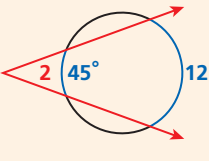

Angle Relationships in Circles

VERTEX OF THE ANGLE	MEASURE OF ANGLE	DIAGRAMS
On a circle	Half the measure of its intercepted arc	 $m\angle 1 = 60^\circ$  $m\angle 2 = 100^\circ$
Inside a circle	Half the sum of the measures of its intercepted arcs	 $m\angle 1 = \frac{1}{2}(44^\circ + 86^\circ)$ $= 65^\circ$
Outside a circle	Half the difference of the measures of its intercepted arcs	 $m\angle 1 = \frac{1}{2}(202^\circ - 78^\circ)$ $= 62^\circ$  $m\angle 2 = \frac{1}{2}(125^\circ - 45^\circ)$ $= 40^\circ$

EXAMPLE 5 Finding Arc Measures

Find $m\widehat{AF}$.

Step 1 Find $m\widehat{ADB}$.

$$m\angle ABC = \frac{1}{2}m\widehat{ADB}$$

If a tangent and secant intersect on a \odot at the pt. of tangency, then the measure of the \angle formed is half the measure of its intercepted arc.

Substitute 110 for $m\angle ABC$.

$$110^\circ = \frac{1}{2}m\widehat{ADB}$$

$$m\widehat{ADB} = 220^\circ$$

Mult. both sides by 2.

Step 2 Find $m\widehat{AD}$.

$$m\widehat{ADB} = m\widehat{AD} + m\widehat{DB} \quad \text{Arc Add. Post.}$$

$$220^\circ = m\widehat{AD} + 160^\circ \quad \text{Substitute.}$$

$$m\widehat{AD} = 60^\circ \quad \text{Subtract 160 from both sides.}$$

Step 3 Find $m\widehat{AF}$.

$$m\widehat{AF} = 360^\circ - (m\widehat{AD} + m\widehat{DB} + m\widehat{BF}) \quad \text{Def. of a } \odot$$

$$= 360^\circ - (60^\circ + 160^\circ + 48^\circ) \quad \text{Substitute.}$$

$$= 92^\circ \quad \text{Simplify.}$$

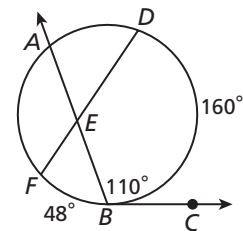

5. Find $m\widehat{LP}$.

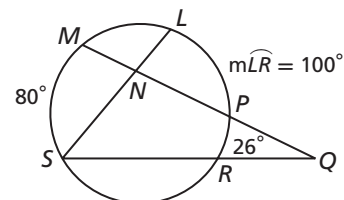

THINK AND DISCUSS

1. Explain how the measure of an angle formed by two chords of a circle is related to the measure of the angle formed by two secants.



2. **GET ORGANIZED** Copy and complete the graphic organizer. In each box write a theorem and draw a diagram according to where the angle's vertex is in relationship to the circle.

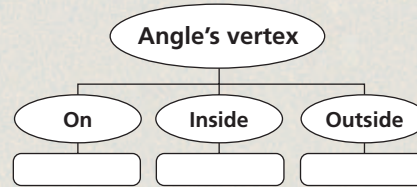

11-5

Exercises



California Standards

7.0, 9.0, 21.0, 7AF1.0

go.hrw.com

Homework Help Online

KEYWORD: MG7 11-5

Parent Resources Online

KEYWORD: MG7 Parent

GUIDED PRACTICE

SEE EXAMPLE 1

1

Find each measure.

p. 782

1. $m\angle DAB$

2. $m\widehat{AC}$

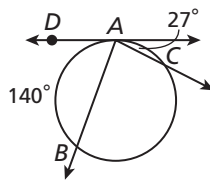

3. $m\widehat{PN}$

4. $m\angle MNP$

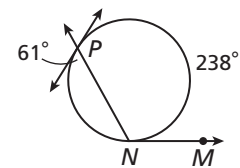

SEE EXAMPLE 2

2

5. $m\angle STU$

p. 783

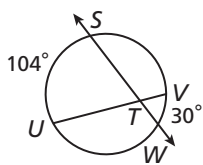

6. $m\angle HFG$

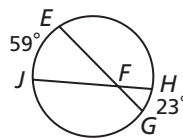

7. $m\angle NPK$

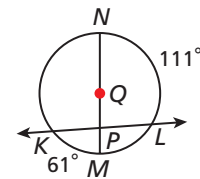

SEE EXAMPLE 3

3

Find the value of x .

p. 784

8.

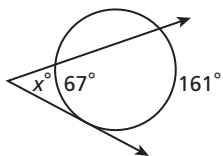

9.

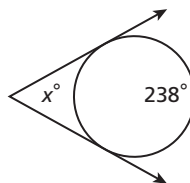

10.

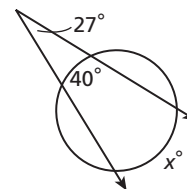

SEE EXAMPLE 4

4

11. **Science** A satellite orbits Mars. When it reaches S it is about 12,000 km above the planet. How many arc degrees of the planet are visible to a camera in the satellite?

p. 784

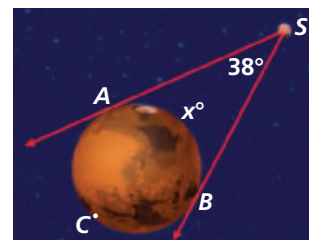

SEE EXAMPLE 5

p. 785

Multi-Step Find each measure.

12. $m\widehat{DF}$

13. $m\widehat{CD}$

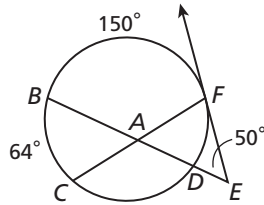

14. $m\widehat{PN}$

15. $m\widehat{KN}$

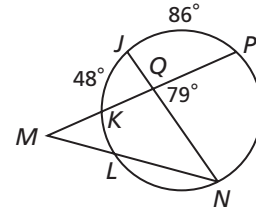

PRACTICE AND PROBLEM SOLVING

Independent Practice

For Exercises	See Example
16–19	1
20–22	2
23–25	3
26	4
27–30	5

Find each measure.

16. $m\angle BCD$

17. $m\angle ABC$

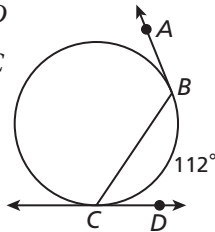

18. $m\angle XZW$

19. $m\widehat{XZV}$

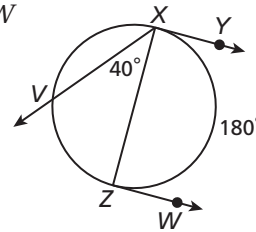

Extra Practice

Skills Practice p. S25

Application Practice p. S38

20. $m\angle QPR$

21. $m\angle ABC$

22. $m\angle MKJ$

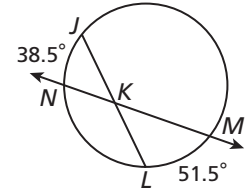
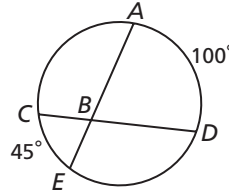
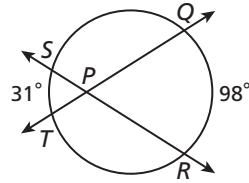

Find the value of x .

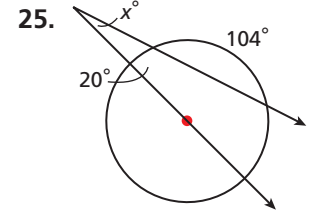
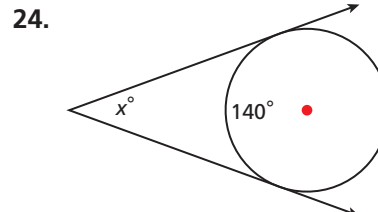
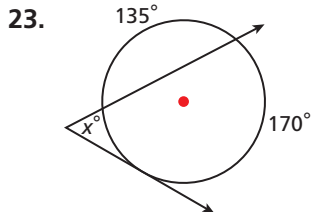

26. **Archaeology** Stonehenge is a circular arrangement of massive stones near Salisbury, England. A viewer at V observes the monument from a point where two of the stones A and B are aligned with stones at the endpoints of a diameter of the circular shape. Given that $m\widehat{AB} = 48^\circ$, what is $m\angle AVB$?

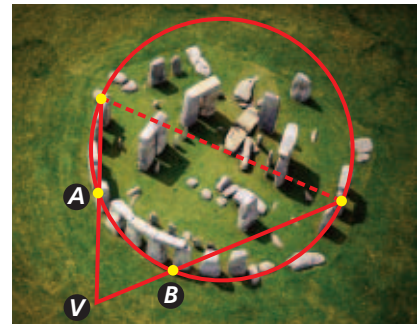

Multi-Step Find each measure.

27. $m\widehat{EG}$

28. $m\widehat{DE}$

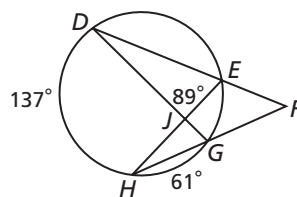

29. $m\widehat{PR}$

30. $m\widehat{LP}$

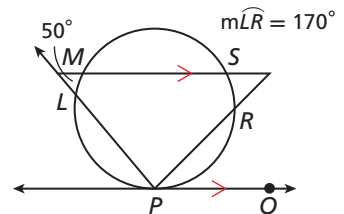

In the diagram, $m\angle ABC = x^\circ$. Write an expression in terms of x for each of the following.

31. $m\widehat{AB}$ 32. $m\angle ABD$ 33. $m\widehat{AEB}$

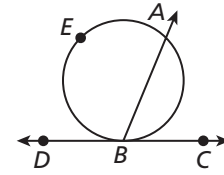

34. **Given:** Tangent \overrightarrow{CD} and secant \overrightarrow{CA}

Prove: $m\angle ACD = \frac{1}{2}(m\widehat{AD} - m\widehat{BD})$

Plan: Draw auxiliary line segment \overline{BD} . Use the Exterior Angle Theorem to show that $m\angle ACD = m\angle ABD - m\angle BDC$. Then use the Inscribed Angle Theorem and Theorem 11-5-1.

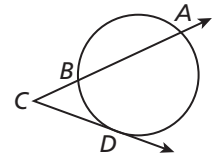

35. **Given:** Tangents \overrightarrow{FE} and \overrightarrow{FG}

Prove: $m\angle EFG = \frac{1}{2}(m\widehat{EHG} - m\widehat{EG})$

36. **Given:** Secants \overline{LJ} and \overline{LN}

Prove: $m\angle JLN = \frac{1}{2}(m\widehat{JN} - m\widehat{KM})$

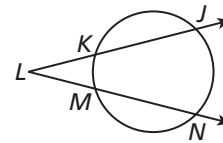
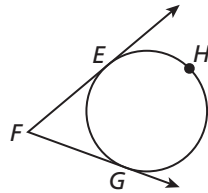

37. **Critical Thinking** Suppose two secants intersect in the exterior of a circle as shown. What is greater, $m\angle 1$ or $m\angle 2$? Justify your answer.

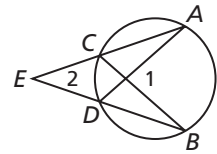

38. **Write About It** The diagrams show the intersection of perpendicular lines on a circle, inside a circle, and outside a circle. Explain how you can use these to help you remember how to calculate the measures of the angles formed.

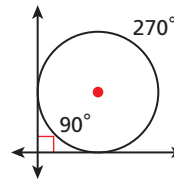
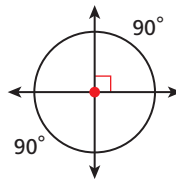
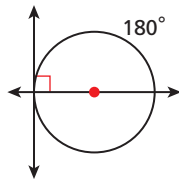

- Algebra** Find the measures of the three angles of $\triangle ABC$.

39. $(2x - 10)^\circ$ x° 160°

40. $(18x - 15)^\circ$ $4x^\circ$ $(8x + 1)^\circ$

CONCEPT CONNECTION



41. This problem will prepare you for the Concept Connection on page 806. The design was made by placing six equally-spaced points on a circle and connecting them.
- Find $m\angle BHC$.
 - Find $m\angle EGD$.
 - Classify $\triangle EGD$ by its angle measures and by its side lengths.

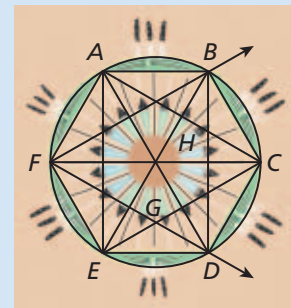

42. What is $m\angle DCE$?

- (A) 19° (C) 79°
 (B) 21° (D) 101°

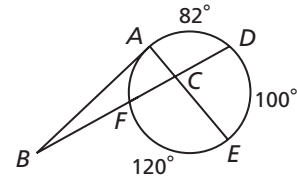

43. Which expression can be used to calculate $m\angle ABC$?

- (F) $\frac{1}{2}(m\widehat{AD} + m\widehat{AF})$ (H) $\frac{1}{2}(m\widehat{DE} - m\widehat{AF})$
 (G) $\frac{1}{2}(m\widehat{DE} + m\widehat{AF})$ (J) $\frac{1}{2}(m\widehat{AD} - m\widehat{AF})$

44. **Gridded Response** In $\odot Q$, $m\widehat{MN} = 146^\circ$ and $m\angle JLK = 45^\circ$. Find the degree measure of \widehat{JK} .

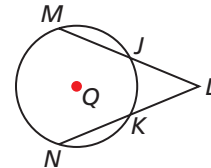

CHALLENGE AND EXTEND

45. Prove Theorem 11-5-1.

Given: Tangent \overrightarrow{BC} and secant \overrightarrow{BA}

Prove: $m\angle ABC = \frac{1}{2}m\widehat{AB}$

(Hint: Consider two cases, one where \overline{AB} is a diameter and one where \overline{AB} is not a diameter.)

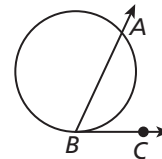

46. **Given:** \overline{YZ} and \overline{WZ} are tangent to $\odot X$. $m\widehat{WY} = 90^\circ$
Prove: $WXYZ$ is a square.

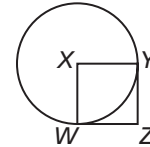

47. Find x .

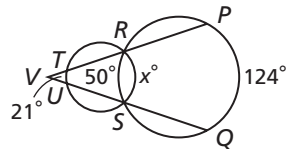

48. Find $m\widehat{GH}$.

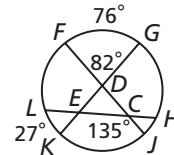

SPIRAL REVIEW

Determine whether the ordered pair $(7, -8)$ is a solution of the following functions. (Previous course)

49. $g(x) = 2x^2 - 15x - 1$ 50. $f(x) = 29 - 3x$ 51. $y = -\frac{7}{8}x$

Find the volume of each pyramid or cone. Round to the nearest tenth. (Lesson 10-7)

52. regular hexagonal pyramid with a base edge of 4 m and a height of 7 m
 53. right cone with a diameter of 12 cm and lateral area of $60\pi \text{ cm}^2$
 54. regular square pyramid with a base edge of 24 in. and a surface area of 1200 in^2

In $\odot P$, find each angle measure. (Lesson 11-4)

55. $m\angle BCA$ 56. $m\angle DBC$ 57. $m\angle ADC$

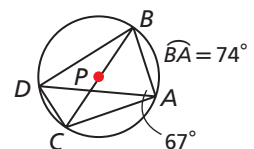

Explore Segment Relationships in Circles

When secants, chords, or tangents of circles intersect, they create several segments. You will measure these segments and investigate their relationships.

Use with Lesson 11-6



California Standards

- 🔑 **7.0** Students prove and use theorems involving the properties of parallel lines cut by a transversal, the properties of quadrilaterals, and the properties of circles.
- 🔑 **21.0** Students prove and solve problems regarding relationships among chords, secants, tangents, inscribed angles, and inscribed and circumscribed polygons of circles.

Also covered: 🔑 **1.0**

go.hrw.com
Lab Resources Online
KEYWORD: MG7 Lab11

Activity 1

- 1 Construct a circle with center A . Label the point on the circle as B . Construct two secants \overline{CD} and \overline{EF} that intersect *outside* the circle at G . Hide B if desired. (It controls the circle's size.)
- 2 Measure \overline{GC} , \overline{GD} , \overline{GE} , and \overline{GF} . Drag points around the circle and examine the changes in the measurements.
- 3 Fill in the segment lengths in a chart like the one below. Find the products of the lengths of segments on the *same* secant. Can you make a conjecture about the relationship of the segments formed by intersecting secants of a circle?

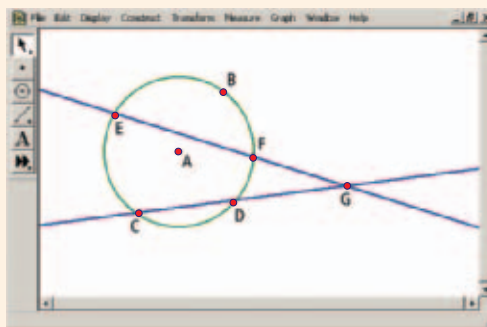

GC	GD	$GC \cdot GD$	GE	GF	$GE \cdot GF$

Try This

1. Make a sketch of the diagram from Activity 1, and create \overline{CF} and \overline{DE} to create $\triangle CFG$ and $\triangle EDG$ as shown.
2. Name pairs of congruent angles in the diagram. How are $\triangle CFG$ and $\triangle EDG$ related? Explain your reasoning.
3. Write a proportion involving sides of the triangles. Cross-multiply and state the result. What do you notice?

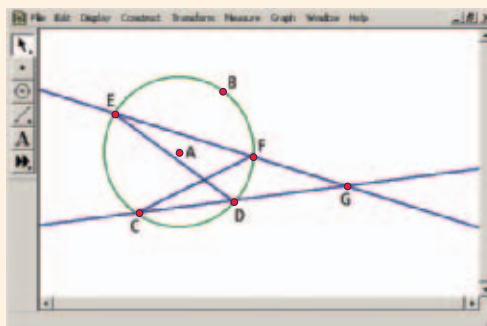

Activity 2

- 1 Construct a new circle with center A . Label the point on the circle as B . Create a radius segment from A to a new point C on the circle.
- 2 Construct a line through C perpendicular to radius \overline{AC} . Create a new point D on this line, which is tangent to circle A at C . Hide radius \overline{AC} .

- 3 Create a secant line through D that intersects the circle at two new points E and F , as shown.
- 4 Measure \overline{DC} , \overline{DE} , and \overline{DF} . Drag points around the circle and examine the changes in the measurements. Fill in the measurements in a chart like the one below. Can you make a conjecture about the relationship between the segments of a tangent and a secant of a circle?

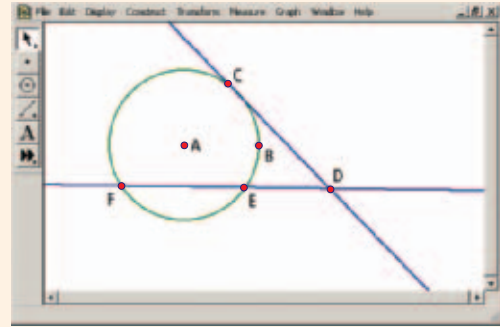

DE	DF	$DE \cdot DF$	DC	?

Try This

4. How are the products for a tangent and a secant similar to the products for secant segments?
5. Try dragging E and F so they overlap (to make the secant segment look like a tangent segment). What do you notice about the segment lengths you measured in Activity 2? Can you state a relationship about two tangent segments from the same exterior point?
6. **Challenge** Write a formal proof of the relationship you found in Problem 2.

Activity 3

- 1 Construct a new circle with two chords \overline{CD} and \overline{EF} that intersect inside the circle at G .
- 2 Measure \overline{GC} , \overline{GD} , \overline{GE} , and \overline{GF} . Drag points around the circle and examine the changes in the measurements.
- 3 Fill in the segment lengths in a chart like the ones used in Activities 1 and 2. Find the products of the lengths of segments on the same chord. Can you make a conjecture about the relationship of the segments formed by intersecting chords of a circle?

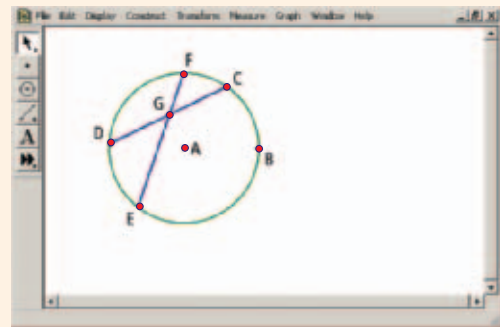

Try This

7. Connect the endpoints of the chords to form two triangles. Name pairs of congruent angles. How are the two triangles that are formed related? Explain your reasoning.
8. Examine the conclusions you made in all three activities about segments formed by secants, chords, and tangents in a circle. Summarize your findings.

11-6

Segment Relationships in Circles



Objectives

Find the lengths of segments formed by lines that intersect circles.

Use the lengths of segments in circles to solve problems.

Vocabulary

secant segment
external secant segment
tangent segment

Who uses this?

Archaeologists use facts about segments in circles to help them understand ancient objects. (See Example 2.)

In 1901, divers near the Greek island of Antikythera discovered several fragments of ancient items. Using the mathematics of circles, scientists were able to calculate the diameters of the complete disks.

The following theorem describes the relationship among the four segments that are formed when two chords intersect in the interior of a circle.



Theorem 11-6-1 Chord-Chord Product Theorem

THEOREM	HYPOTHESIS	CONCLUSION
If two chords intersect in the interior of a circle, then the products of the lengths of the segments of the chords are equal.	<p>Chords \overline{AB} and \overline{CD} intersect at E.</p>	$AE \cdot EB = CE \cdot ED$

You will prove Theorem 11-6-1 in Exercise 28.

EXAMPLE 1 Applying the Chord-Chord Product Theorem



Find the value of x and the length of each chord.

$$PQ \cdot QR = SQ \cdot QT$$

$$6(4) = x(8)$$

$$24 = 8x$$

$$3 = x$$

$$PR = 6 + 4 = 10$$

$$ST = 3 + 8 = 11$$

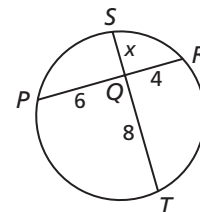

California Standards

7.0 Students prove and use theorems involving the properties of parallel lines cut by a transversal, the properties of quadrilaterals, and the properties of circles.

21.0 Students prove and solve problems regarding relationships among chords, secants, tangents, inscribed angles, and inscribed and circumscribed polygons of circles.



1. Find the value of x and the length of each chord.

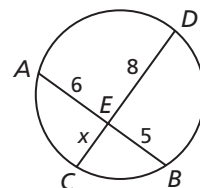

EXAMPLE 2 Archaeology Application



Archaeologists discovered a fragment of an ancient disk. To calculate its original diameter, they drew a chord \overline{AB} and its perpendicular bisector \overline{PQ} . Find the disk's diameter.

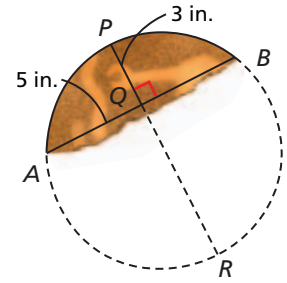

Since \overline{PQ} is the perpendicular bisector of a chord, \overline{PR} is a diameter of the disk.

$$AQ \cdot QB = PQ \cdot QR$$

$$5(5) = 3(QR)$$

$$25 = 3QR$$

$$8\frac{1}{3} \text{ in.} = QR$$

$$PR = 3 + 8\frac{1}{3} = 11\frac{1}{3} \text{ in.}$$



2. **What if...?** Suppose the length of chord \overline{AB} that the archaeologists drew was 12 in. In this case how much longer is the disk's diameter compared to the disk in Example 2?

A **secant segment** is a segment of a secant with at least one endpoint on the circle. An **external secant segment** is a secant segment that lies in the exterior of the circle with one endpoint on the circle.

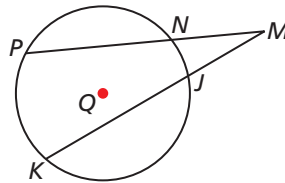

\overline{PM} , \overline{NM} , \overline{KM} , and \overline{JM} are secant segments of $\odot Q$. \overline{NM} and \overline{JM} are external secant segments.



Theorem 11-6-2 Secant-Secant Product Theorem

THEOREM	HYPOTHESIS	CONCLUSION
If two secants intersect in the exterior of a circle, then the product of the lengths of one secant segment and its external segment equals the product of the lengths of the other secant segment and its external segment. (whole \cdot outside = whole \cdot outside)	<p>Secants \overline{AE} and \overline{CE} intersect at E.</p>	$AE \cdot BE = CE \cdot DE$

PROOF Secant-Secant Product Theorem

Given: Secant segments \overline{AE} and \overline{CE}

Prove: $AE \cdot BE = CE \cdot DE$

Proof: Draw auxiliary line segments \overline{AD} and \overline{CB} .

$\angle EAD$ and $\angle ECB$ both intercept \widehat{BD} , so

$\angle EAD \cong \angle ECB$. $\angle E \cong \angle E$ by the Reflexive Property of \cong .

Thus $\triangle EAD \sim \triangle ECB$ by AA Similarity. Therefore corresponding

sides are proportional, and $\frac{AE}{CE} = \frac{DE}{BE}$. By the Cross Products Property, $AE \cdot BE = CE \cdot DE$.

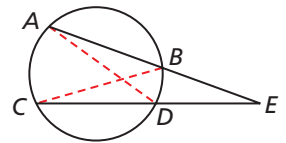

EXAMPLE 3 Applying the Secant-Secant Product Theorem



Find the value of x and the length of each secant segment.

$$\begin{aligned}
 RT \cdot RS &= RQ \cdot RP \\
 10(4) &= (x + 5)5 \\
 40 &= 5x + 25 \\
 15 &= 5x \\
 3 &= x \\
 RT &= 4 + 6 = 10 \\
 RQ &= 5 + 3 = 8
 \end{aligned}$$

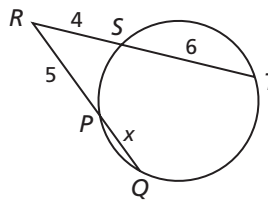

3. Find the value of z and the length of each secant segment.

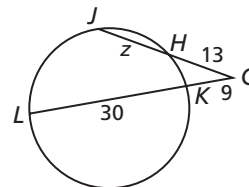

A **tangent segment** is a segment of a tangent with one endpoint on the circle. \overline{AB} and \overline{AC} are tangent segments.

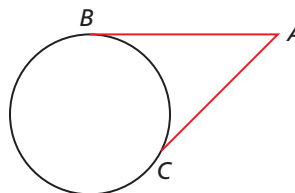

Theorem 11-6-3 Secant-Tangent Product Theorem

THEOREM	HYPOTHESIS	CONCLUSION
If a secant and a tangent intersect in the exterior of a circle, then the product of the lengths of the secant segment and its external segment equals the length of the tangent segment squared. (whole \cdot outside = tangent ²)	<p>Secant \overline{AC} and tangent \overline{DC} intersect at C.</p>	$AC \cdot BC = DC^2$

You will prove Theorem 11-6-3 in Exercise 29.

EXAMPLE 4 Applying the Secant-Tangent Product Theorem



Find the value of x .

$$\begin{aligned}
 SQ \cdot RQ &= PQ^2 \\
 9(4) &= x^2 \\
 36 &= x^2 \\
 \pm 6 &= x
 \end{aligned}$$

The value of x must be 6 since it represents a length.

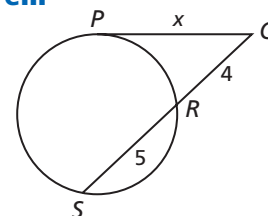

4. Find the value of y .

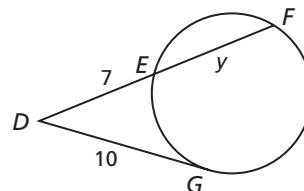

THINK AND DISCUSS

- Does the Chord-Chord Product Theorem apply when both chords are diameters? If so, what does the theorem tell you in this case?
- Given A in the exterior of a circle, how many different tangent segments can you draw with A as an endpoint?
- GET ORGANIZED** Copy and complete the graphic organizer.



	Theorem	Diagram	Example
Chord-Chord			
Secant-Secant			
Secant-Tangent			

11-6

Exercises



California Standards

7.0, 8.0, 14.0,
21.0, 6SDAP3.0, 1A2.0



go.hrw.com

Homework Help Online

KEYWORD: MG7 11-6

Parent Resources Online

KEYWORD: MG7 Parent

GUIDED PRACTICE

- Vocabulary** \overleftrightarrow{AB} intersects $\odot P$ at exactly one point. Point A is in the exterior of $\odot P$, and point B lies on $\odot P$. \overline{AB} is a(n) _____. (*tangent segment* or *external secant segment*)

SEE EXAMPLE 1

p. 792

- Find the value of the variable and the length of each chord.

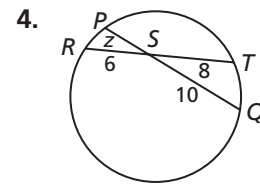
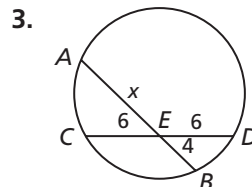
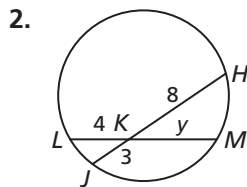

SEE EXAMPLE 2

p. 793

- Engineering** A section of an aqueduct is based on an arc of a circle as shown. \overline{EF} is the perpendicular bisector of \overline{GH} . $GH = 50$ ft, and $EF = 20$ ft. What is the diameter of the circle?

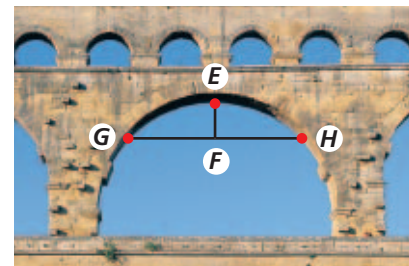

SEE EXAMPLE 3

p. 794

- Find the value of the variable and the length of each secant segment.

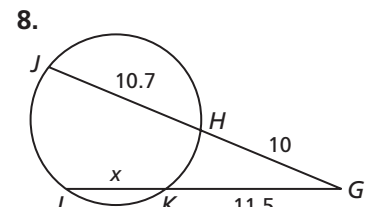
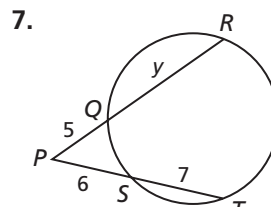
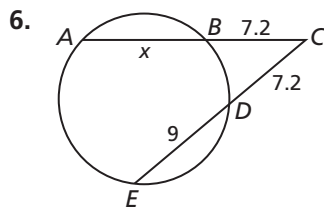

SEE EXAMPLE 4

p. 794

Find the value of the variable.

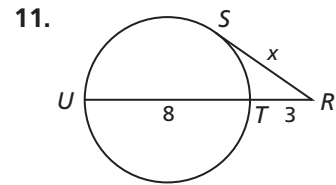
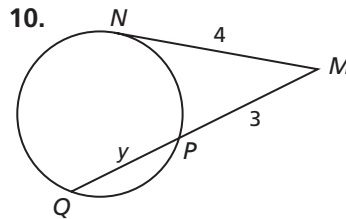
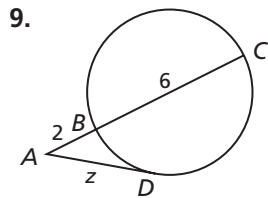

PRACTICE AND PROBLEM SOLVING

Find the value of the variable and the length of each chord.

Independent Practice

For Exercises	See Example
12–14	1
15	2
16–18	3
19–21	4

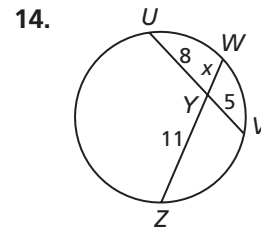
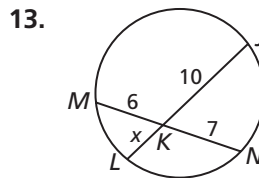
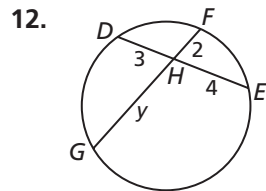

Extra Practice

Skills Practice p. S25

Application Practice p. S38

15. **Geology** Molokini is a small, crescent-shaped island $2\frac{1}{2}$ miles from the Maui coast. It is all that remains of an extinct volcano. To approximate the diameter of the mouth of the volcano, a geologist can use a diagram like the one shown. What is the approximate diameter of the volcano's mouth to the nearest foot?



Find the value of the variable and the length of each secant segment.

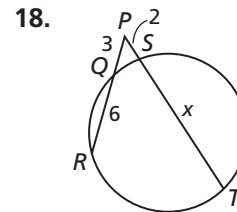
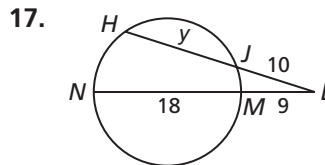
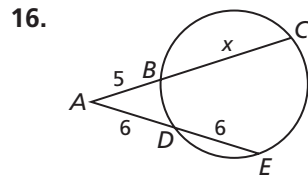

Find the value of the variable.

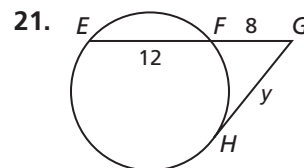
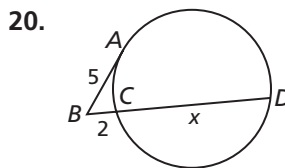
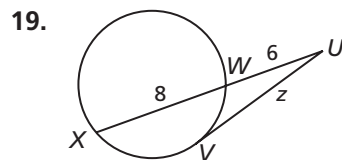

Use the diagram for Exercises 22 and 23.

22. M is the midpoint of \overline{PQ} . $RM = 10$ cm, and $PQ = 24$ cm.
 a. Find MS .
 b. Find the diameter of $\odot O$.
23. M is the midpoint of \overline{PQ} . The diameter of $\odot O$ is 13 in., and $RM = 4$ in.
 a. Find PM .
 b. Find PQ .

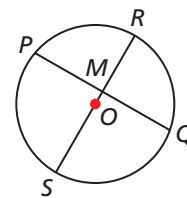



Meteorology

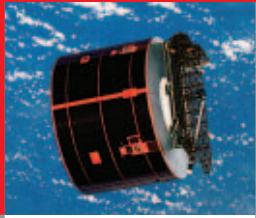

Satellites are launched to an area above the atmosphere where there is no friction. The idea is to position them so that when they fall back toward Earth, they fall at the same rate as Earth's surface falls away from them.

Multi-Step Find the value of both variables in each figure.

24.

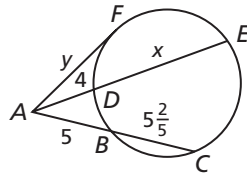

25.

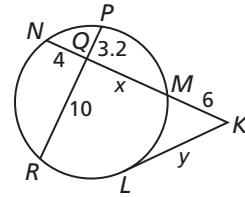

26. **Meteorology** A weather satellite S orbits Earth at a distance SE of 6000 mi. Given that the diameter of the earth is approximately 8000 mi, what is the distance from the satellite to P ? Round to the nearest mile.

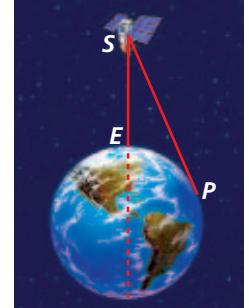

27. **ERROR ANALYSIS** The two solutions show how to find the value of x . Which solution is incorrect? Explain the error.

A

$$\begin{aligned} AC \cdot BC &= DC^2, \text{ so} \\ 10(4) &= x^2. x^2 = 40, \\ \text{and } x &= 2\sqrt{10}. \end{aligned}$$

B

$$\begin{aligned} AB \cdot BC &= DC^2, \text{ so} \\ 6(4) &= x^2. x^2 = 24, \\ \text{and } x &= 2\sqrt{6}. \end{aligned}$$

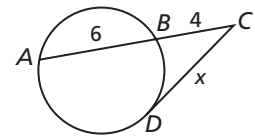

28. Prove Theorem 11-6-1.

Given: Chords \overline{AB} and \overline{CD} intersect at point E .

Prove: $AE \cdot EB = CE \cdot ED$

Plan: Draw auxiliary line segments \overline{AC} and \overline{BD} . Show that $\triangle ECA \sim \triangle EBD$. Then write a proportion comparing the lengths of corresponding sides.

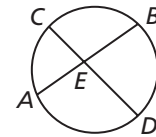

29. Prove Theorem 11-6-3.

Given: Secant segment \overline{AC} , tangent segment \overline{DC}

Prove: $AC \cdot BC = DC^2$

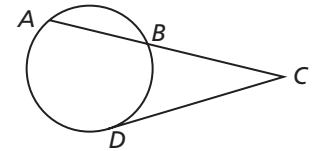

30. **Critical Thinking** A student drew a circle and two secant segments. By measuring with a ruler, he found $\overline{PQ} \cong \overline{PS}$. He concluded that $\overline{QR} \cong \overline{ST}$. Do you agree with the student's conclusion? Why or why not?

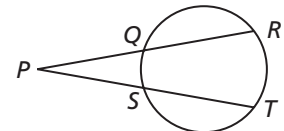

31. **Write About It** The radius of $\odot A$ is 4. $CD = 4$, and \overline{CB} is a tangent segment. Describe two different methods you can use to find BC .

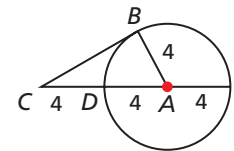

CONCEPT CONNECTION



32. This problem will prepare you for the Concept Connection on page 806.

Some Native American designs are based on eight points that are placed around the circumference of a circle. In $\odot O$, $BE = 3$ cm, $AE = 5.2$ cm, and $EC = 4$ cm.

- Find DE to the nearest tenth.
- What is the diameter of the circle to the nearest tenth?
- What is the length of \overline{OE} to the nearest hundredth?

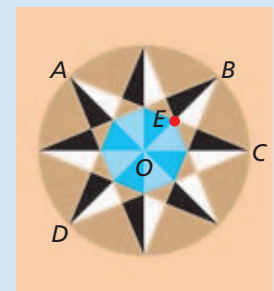

33. Which of these is closest to the length of tangent \overline{PQ} ?
 (A) 6.9 (B) 9.2 (C) 9.9 (D) 10.6
34. What is the length of \overline{UT} ?
 (F) 5 (G) 7 (H) 12 (J) 14
35. **Short Response** In $\odot A$, \overline{AB} is the perpendicular bisector of \overline{CD} . $CD = 12$, and $EB = 3$. Find the radius of $\odot A$. Explain your steps.

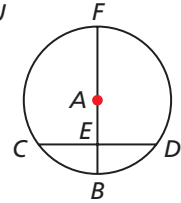
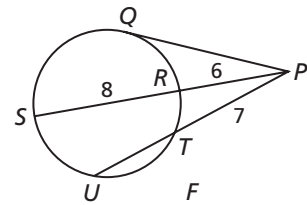

CHALLENGE AND EXTEND



36. **Algebra** \overline{KL} is a tangent segment of $\odot N$.
 a. Find the value of x .
 b. Classify $\triangle KLM$ by its angle measures. Explain.
37. \overline{PQ} is a tangent segment of a circle with radius 4 in. Q lies on the circle, and $PQ = 6$ in. Find the distance from P to the circle. Round to the nearest tenth of an inch.
38. The circle in the diagram has radius c . Use this diagram and the Chord-Chord Product Theorem to prove the Pythagorean Theorem.
39. Find the value of y to the nearest hundredth.

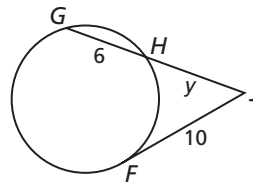
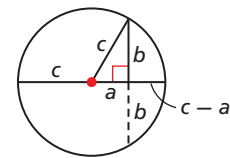
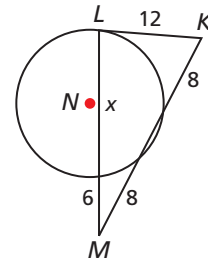

SPIRAL REVIEW

40. An experiment was conducted to find the probability of rolling two threes in a row on a number cube. The probability was 3.5%. How many trials were performed in this experiment if 14 favorable outcomes occurred? (*Previous course*)
41. Two coins were flipped together 50 times. In 36 of the flips, at least one coin landed heads up. Based on this experiment, what is the experimental probability that at least one coin will land heads up when two coins are flipped? (*Previous course*)

Name each of the following. (*Lesson 1-1*)

42. two rays that do not intersect
43. the intersection of \overrightarrow{AC} and \overrightarrow{CD}
44. the intersection of \overrightarrow{CA} and \overrightarrow{BD}

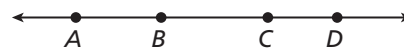

Find each measure. Give your answer in terms of π and rounded to the nearest hundredth. (*Lesson 11-3*)

45. area of the sector XZW
46. arc length of \widehat{XW}
47. $m\angle YZX$ if the area of the sector YZW is $40\pi \text{ ft}^2$

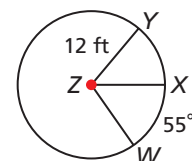

11-7

Circles in the Coordinate Plane

Objectives

Write equations and graph circles in the coordinate plane.

Use the equation and graph of a circle to solve problems.

California Standards

7.0 Students prove and use theorems involving the properties of parallel lines cut by a transversal, the properties of quadrilaterals, and the properties of circles.

Who uses this?

Meteorologists use circles and coordinates to plan the location of weather stations. (See Example 3.)

The equation of a circle is based on the Distance Formula and the fact that all points on a circle are equidistant from the center.

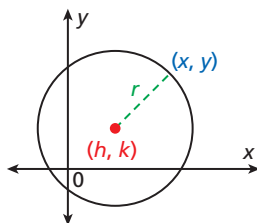

$$d = \sqrt{(x_2 - x_1)^2 + (y_2 - y_1)^2} \quad \text{Distance Formula}$$

$$r = \sqrt{(x - h)^2 + (y - k)^2} \quad \text{Substitute the given values.}$$

$$r^2 = (x - h)^2 + (y - k)^2 \quad \text{Square both sides.}$$

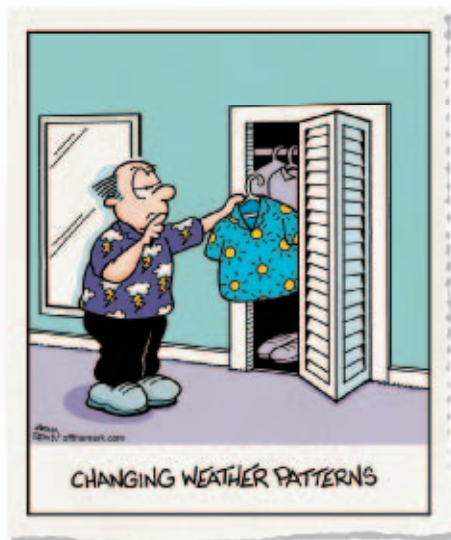

Theorem 11-7-1 Equation of a Circle

The equation of a circle with center (h, k) and radius r is $(x - h)^2 + (y - k)^2 = r^2$.

EXAMPLE 1 Writing the Equation of a Circle



Write the equation of each circle.

A $\odot A$ with center $A(4, -2)$ and radius 3

$$(x - h)^2 + (y - k)^2 = r^2 \quad \text{Equation of a circle}$$

$$(x - 4)^2 + (y - (-2))^2 = 3^2 \quad \text{Substitute 4 for } h, -2 \text{ for } k, \text{ and 3 for } r.$$

$$(x - 4)^2 + (y + 2)^2 = 9 \quad \text{Simplify.}$$

B $\odot B$ that passes through $(-2, 6)$ and has center $B(-6, 3)$

$$r = \sqrt{(-2 - (-6))^2 + (6 - 3)^2} \quad \text{Distance Formula}$$

$$= \sqrt{25} = 5 \quad \text{Simplify.}$$

$$(x - (-6))^2 + (y - 3)^2 = 5^2 \quad \text{Substitute } -6 \text{ for } h, 3 \text{ for } k, \text{ and 5 for } r.$$

$$(x + 6)^2 + (y - 3)^2 = 25 \quad \text{Simplify.}$$



Write the equation of each circle.

1a. $\odot P$ with center $P(0, -3)$ and radius 8

1b. $\odot Q$ that passes through $(2, 3)$ and has center $Q(2, -1)$

If you are given the equation of a circle, you can graph the circle by making a table or by identifying its center and radius.

EXAMPLE 2 Graphing a Circle



Graph each equation.

A $x^2 + y^2 = 25$

Step 1 Make a table of values.

Since the radius is $\sqrt{25}$, or 5, use ± 5 and the values between for x -values.

x	-5	-4	-3	0	3	4	5
y	0	± 3	± 4	± 5	± 4	± 3	0

Step 2 Plot the points and connect them to form a circle.

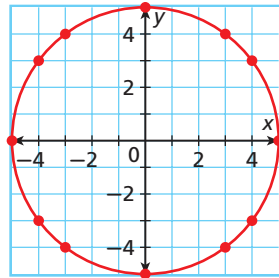

Helpful Hint

Always compare the equation to the form $(x - h)^2 + (y - k)^2 = r^2$.

B $(x + 1)^2 + (y - 2)^2 = 9$

The equation of the given circle can be written as $(x - (-1))^2 + (y - 2)^2 = 3^2$. So $h = -1$, $k = 2$, and $r = 3$.

The center is $(-1, 2)$, and the radius is 3. Plot the point $(-1, 2)$. Then graph a circle having this center and radius 3.

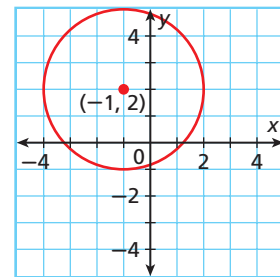

Graph each equation.

2a. $x^2 + y^2 = 9$

2b. $(x - 3)^2 + (y + 2)^2 = 4$

Student to Student

Graphing Circles



Christina Avila
Crockett High School

I found a way to use my calculator to graph circles. You first need to write the circle's equation in $y =$ form.

For example, to graph $x^2 + y^2 = 16$, first solve for y .

$$y^2 = 16 - x^2$$

$$y = \pm\sqrt{16 - x^2}$$

Now enter and graph the two equations

$$y_1 = \sqrt{16 - x^2} \text{ and } y_2 = -\sqrt{16 - x^2}.$$

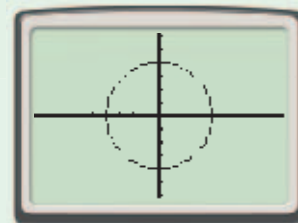

EXAMPLE 3 Meteorology Application

Meteorologists are planning the location of a new weather station to cover Osceola, Waco, and Ireland, Texas. To optimize radar coverage, the station must be equidistant from the three cities which are located on a coordinate plane at $A(2, 5)$, $B(3, -2)$, and $C(-5, -2)$.

- What are the coordinates where the station should be built?
- If each unit of the coordinate plane represents 8.5 miles, what is the diameter of the region covered by the radar?

Step 1 Plot the three given points.

Step 2 Connect A , B , and C to form a triangle.

Step 3 Find a point that is equidistant from the three points by constructing the perpendicular bisectors of two of the sides of $\triangle ABC$.

The perpendicular bisectors of the sides of $\triangle ABC$ intersect at a point that is equidistant from A , B , and C .

The intersection of the perpendicular bisectors is $P(-1, 1)$. P is the center of the circle that passes through A , B , and C .

The weather station should be built at $P(-1, 1)$, Clifton, Texas.

There are approximately 10 units across the circle. So the diameter of the region covered by the radar is approximately 85 miles.

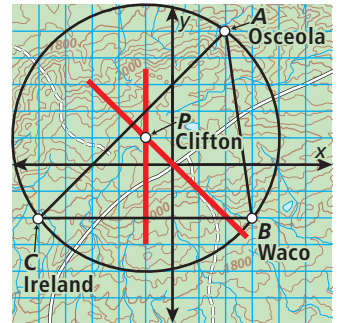
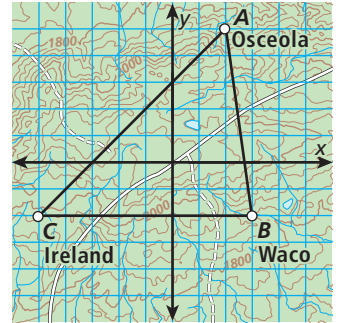

Remember!

The perpendicular bisectors of a triangle are concurrent at a point equidistant from each vertex.



- 3. What if...?** Suppose the coordinates of the three cities in Example 3 are $D(6, 2)$, $E(5, -5)$, and $F(-2, -4)$. What would be the location of the weather station?

THINK AND DISCUSS

- What is the equation of a circle with radius r whose center is at the origin?
- A circle has a diameter with endpoints $(1, 4)$ and $(-3, 4)$. Explain how you can find the equation of the circle.
- Can a circle have a radius of -6 ? Justify your answer.
- GET ORGANIZED** Copy and complete the graphic organizer. First select values for a center and radius. Then use the center and radius you wrote to fill in the other circles. Write the corresponding equation and draw the corresponding graph.

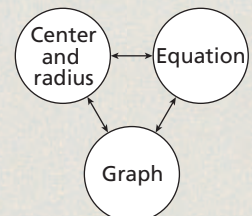



- 7.0, 8.0, 7AF1.1,
1A2.0, 1A9.0,
1A10.0



GUIDED PRACTICE

SEE EXAMPLE 1

p. 799

Write the equation of each circle.

- ⊙A with center $A(3, -5)$ and radius 12
- ⊙B with center $B(-4, 0)$ and radius 7
- ⊙M that passes through $(2, 0)$ and that has center $M(4, 0)$
- ⊙N that passes through $(2, -2)$ and that has center $N(-1, 2)$

SEE EXAMPLE 2

p. 800

Multi-Step Graph each equation.

- $(x - 3)^2 + (y - 3)^2 = 4$
- $(x - 1)^2 + (y + 2)^2 = 9$
- $(x + 3)^2 + (y + 4)^2 = 1$
- $(x - 3)^2 + (y + 4)^2 = 16$

SEE EXAMPLE 3

p. 801

- Communications** A radio antenna tower is kept perpendicular to the ground by three wires of equal length. The wires touch the ground at three points on a circle whose center is at the base of the tower. The wires touch the ground at $A(2, 6)$, $B(-2, -2)$, and $C(-5, 7)$.
 - What are the coordinates of the base of the tower?
 - Each unit of the coordinate plane represents 1 ft. What is the diameter of the circle?

PRACTICE AND PROBLEM SOLVING

Independent Practice

For Exercises	See Example
10–13	1
14–17	2
18	3

Extra Practice

Skills Practice p. S25

Application Practice p. S38

Write the equation of each circle.

- ⊙R with center $R(-12, -10)$ and radius 8
- ⊙S with center $S(1.5, -2.5)$ and radius $\sqrt{3}$
- ⊙C that passes through $(2, 2)$ and that has center $C(1, 1)$
- ⊙D that passes through $(-5, 1)$ and that has center $D(1, -2)$

Multi-Step Graph each equation.

- $x^2 + (y - 2)^2 = 9$
- $(x + 1)^2 - y^2 = 16$
- $x^2 + y^2 = 100$
- $x^2 + (y + 2)^2 = 4$

- Anthropology** Hundreds of stone circles can be found along the Gambia River in western Africa. The stones are believed to be over 1000 years old. In one of the circles at Ker Batch, three stones have approximate coordinates of $A(3, 1)$, $B(4, -2)$, and $C(-6, -2)$.

- What are the coordinates of the center of the stone circle?
- Each unit of the coordinate plane represents 1 ft. What is the diameter of the stone circle?



 **Algebra** Write the equation of each circle.

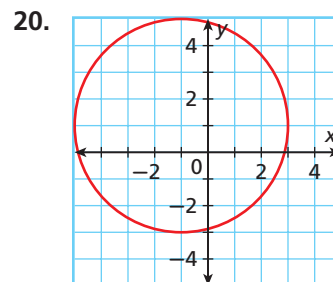
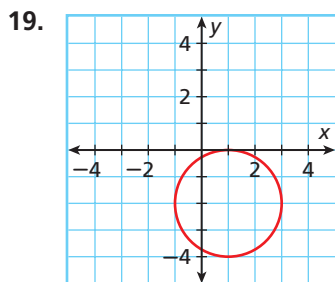

21. **Entertainment** In 2004, the world's largest carousel was located at the House on the Rock, in Spring Green, Wisconsin. Suppose that the center of the carousel is at the origin and that one of the animals on the circumference of the carousel has coordinates $(24, 32)$.
- If one unit of the coordinate plane equals 1 ft, what is the diameter of the carousel?
 - As the carousel turns, the animals follow a circular path. Write the equation of this circle.

Determine whether each statement is true or false. If false, explain why.

- The circle $x^2 + y^2 = 7$ has radius 7.
- The circle $(x - 2)^2 + (y + 3)^2 = 9$ passes through the point $(-1, -3)$.
- The center of the circle $(x - 6)^2 + (y + 4)^2 = 1$ lies in the second quadrant.
- The circle $(x + 1)^2 + (y - 4)^2 = 4$ intersects the y -axis.
- The equation of the circle centered at the origin with diameter 6 is $x^2 + y^2 = 36$.
- Estimation** You can use the graph of a circle to estimate its area.

- Estimate the area of the circle by counting the number of squares of the coordinate plane contained in its interior. Be sure to count partial squares.
- Find the radius of the circle. Then use the area formula to calculate the circle's area to the nearest tenth.
- Was your estimate in part **a** an overestimate or an underestimate?

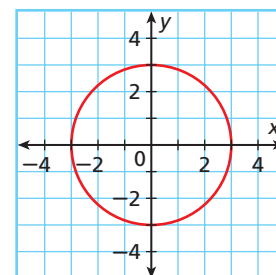

- Consider the circle whose equation is $(x - 4)^2 + (y + 6)^2 = 25$. Write, in point-slope form, the equation of the line tangent to the circle at $(1, -10)$.

CONCEPT CONNECTION



29. This problem will prepare you for the Concept Connection on page 806.

A *hogan* is a traditional Navajo home. An artist is using a coordinate plane to draw the symbol for a hogan. The symbol is based on eight equally spaced points placed around the circumference of a circle.

- She positions the symbol at $A(-3, 5)$ and $C(0, 2)$. What are the coordinates of E and G ?
- What is the length of a diameter of the symbol?
- Use your answer from part **b** to write an equation of the circle.

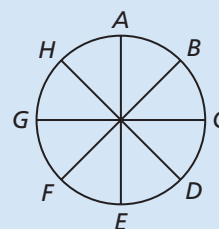

Find the center and radius of each circle.

30. $(x - 2)^2 + (y + 3)^2 = 81$ 31. $x^2 + (y + 15)^2 = 25$ 32. $(x + 1)^2 + y^2 = 7$

Find the area and circumference of each circle. Express your answer in terms of π .

33. circle with equation $(x + 2)^2 + (y - 7)^2 = 9$
 34. circle with equation $(x - 8)^2 + (y + 5)^2 = 7$
 35. circle with center $(-1, 3)$ that passes through $(2, -1)$
 36. **Critical Thinking** Describe the graph of the equation $x^2 + y^2 = r^2$ when $r = 0$.

37. **Geology** A seismograph measures ground motion during an earthquake. To find the epicenter of an earthquake, scientists take readings in three different locations. Then they draw a circle centered at each location. The radius of each circle is the distance the earthquake is from the seismograph. The intersection of the circles is the epicenter. Use the data below to find the epicenter of the New Madrid earthquake.



Seismograph	Location	Distance to Earthquake
A	$(-200, 200)$	300 mi
B	$(400, -100)$	600 mi
C	$(100, -500)$	500 mi

38. For what value(s) of the constant k is the circle $x^2 + (y - k)^2 = 25$ tangent to the x -axis?
 39. $\odot A$ has a diameter with endpoints $(-3, -2)$ and $(5, -2)$. Write the equation of $\odot A$.
 40. Recall that a locus is the set of points that satisfy a given condition. Draw and describe the locus of points that are 3 units from $(2, 2)$.
 41. **Write About It** The equation of $\odot P$ is $(x - 2)^2 + (y - 1)^2 = 9$. Without graphing, explain how you can determine whether the point $(3, -1)$ lies on $\odot P$, in the interior of $\odot P$, or in the exterior of $\odot P$.



Geology

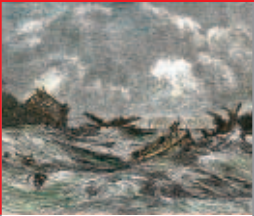

The New Madrid earthquake of 1811 was one of the largest earthquakes known in American history. Large areas sank into the earth, new lakes were formed, forests were destroyed, and the course of the Mississippi River was changed.

The Granger Collection, New York



42. Which of these circles intersects the x -axis?
 (A) $(x - 3)^2 + (y + 3)^2 = 4$ (C) $(x + 2)^2 + (y + 1)^2 = 1$
 (B) $(x + 1)^2 + (y - 4)^2 = 9$ (D) $(x + 1)^2 + (y + 4)^2 = 9$
43. What is the equation of a circle with center $(-3, 5)$ that passes through the point $(1, 5)$?
 (F) $(x + 3)^2 + (y - 5)^2 = 4$ (H) $(x + 3)^2 + (y - 5)^2 = 16$
 (G) $(x - 3)^2 + (y + 5)^2 = 4$ (J) $(x - 3)^2 + (y + 5)^2 = 16$
44. On a map of a park, statues are located at $(4, -2)$, $(-1, 3)$, and $(-5, -5)$. A circular path connects the three statues, and the circle has a fountain at its center. Find the coordinates of the fountain.
 (A) $(-1, -2)$ (B) $(2, 1)$ (C) $(-2, 1)$ (D) $(1, -2)$



Angles and Segments in Circles

Native American Design

The members of a Native American cultural center are painting a circle of colors on their gallery floor. They start by laying out the circle and chords shown. Before they apply their paint to the design, they measure angles and lengths to check for accuracy.

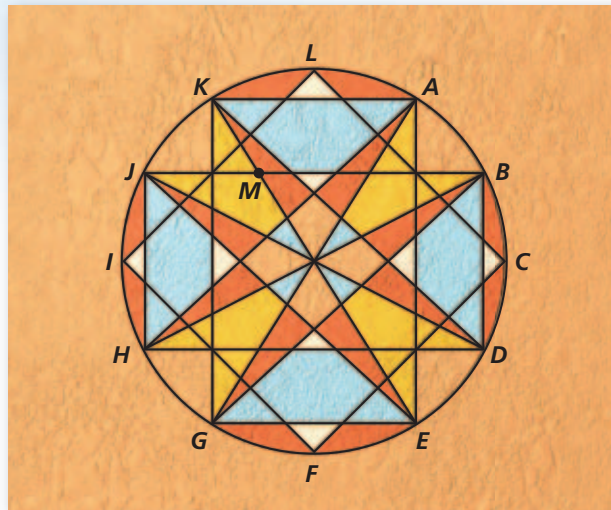

1. The circle design is based on twelve equally spaced points placed around the circumference of the circle. As the group lays out the design, what should be $m\angle AGB$?
2. What should be $m\angle KAE$? Why?
3. What should be $m\angle KMJ$? Why?
4. The diameter of the circle is 22 ft. $KM \approx 4.8$ ft, and $JM \approx 6.4$ ft. What should be the length of MB ?
5. The group members use a coordinate plane to help them position the design. Each square of a grid represents one square foot, and the center of the circle is at $(20, 14)$. What is the equation of the circle?
6. What are the coordinates of points L , C , F , and I ?

Quiz for Lessons 11-4 Through 11-7

11-4 Inscribed Angles

Find each measure.

1. $m\angle BAC$

2. $m\widehat{CD}$

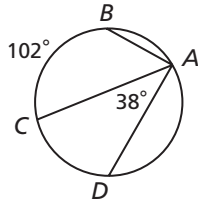

3. $m\angle FGH$

4. $m\widehat{JGF}$

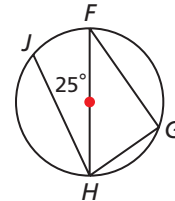

11-5 Angle Relationships in Circles

Find each measure.

5. $m\angle RST$

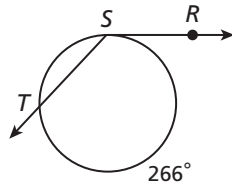

6. $m\angle AEC$

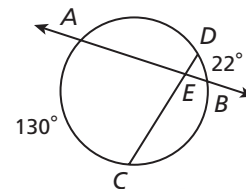

7. A manufacturing company is creating a plastic stand for DVDs. They want to make the stand with $m\widehat{MN} = 102^\circ$. What should be the measure of $\angle MPN$?

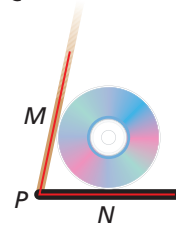

11-6 Segment Relationships in Circles

Find the value of the variable and the length of each chord or secant segment.

8.

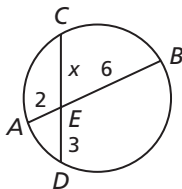

9.

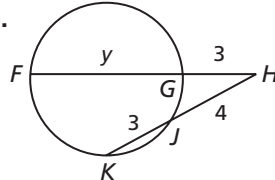

10. An archaeologist discovers a portion of a circular stone wall, shown by \widehat{ST} in the figure. $ST = 12.2$ m, and $UR = 3.9$ m. What was the diameter of the original circular wall? Round to the nearest hundredth.

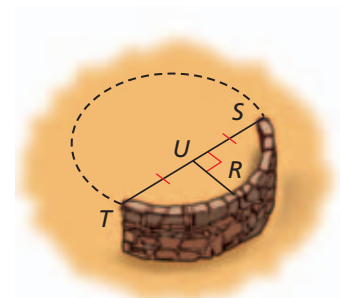

11-7 Circles in the Coordinate Plane

Write the equation of each circle.

- $\odot A$ with center $A(-2, -3)$ and radius 3
- $\odot B$ that passes through $(1, 1)$ and that has center $B(4, 5)$
- A television station serves residents of three cities located at $J(5, 2)$, $K(-7, 2)$, and $L(-5, -8)$. The station wants to build a new broadcast facility that is equidistant from the three cities. What are the coordinates of the location where the facility should be built?

EXTENSION

Polar Coordinates

Objectives

Convert between polar and rectangular coordinates.

Plot points using polar coordinates.

Vocabulary

polar coordinate system
pole
polar axis

In a Cartesian coordinate system, a point is represented by the two coordinates x and y . In a **polar coordinate system**, a point A is represented by its distance from the origin r , and an angle θ . θ is measured counterclockwise from the horizontal axis to \overrightarrow{OA} . The ordered pair (r, θ) represents the polar coordinates of point A .

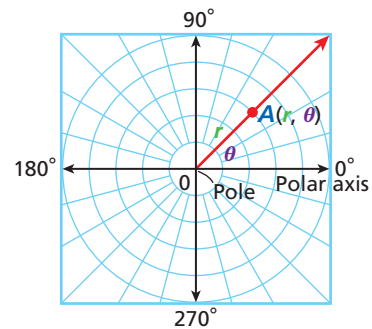

In a polar coordinate system, the origin is called the **pole**. The horizontal axis is called the **polar axis**.

You can use the equation of a circle $r^2 = x^2 + y^2$ and the tangent ratio $\theta = \frac{y}{x}$ to convert rectangular coordinates to polar coordinates.

EXAMPLE 1 Converting Rectangular Coordinates to Polar Coordinates

Convert $(3, 4)$ to polar coordinates.

$$r^2 = x^2 + y^2$$

$$r^2 = 3^2 + 4^2$$

$$r^2 = 25$$

$$r = 5$$

$$\tan \theta = \frac{4}{3}$$

$$\theta = \tan^{-1}\left(\frac{4}{3}\right) \approx 53^\circ$$

The polar coordinates are $(5, 53^\circ)$.

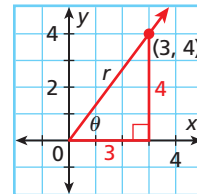

1. Convert $(4, 1)$ to polar coordinates.

You can use the relationships $x = r \cos \theta$ and $y = r \sin \theta$ to convert polar coordinates to rectangular coordinates.

EXAMPLE 2 Converting Polar Coordinates to Rectangular Coordinates

Convert $(2, 130^\circ)$ to rectangular coordinates.

$$x = r \cos \theta \qquad y = r \sin \theta$$

$$x = 2 \cos 130^\circ \qquad y = 2 \sin 130^\circ$$

$$\approx -1.29 \qquad \approx 1.53$$

The rectangular coordinates are $(-1.29, 1.53)$.

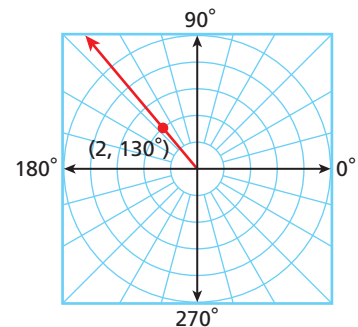

2. Convert $(4, 60^\circ)$ to rectangular coordinates.

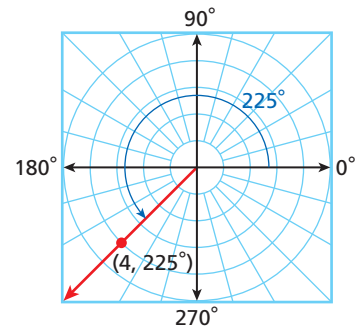
EXAMPLE 3 Plotting Polar CoordinatesPlot the point $(4, 225^\circ)$.**Step 1** Measure 225° counterclockwise from the polar axis.**Step 2** Locate the point on the ray that is 4 units from the pole.3. Plot the point $(4, 300^\circ)$.**EXAMPLE 4** Graphing Polar EquationsGraph $r = 4$.

Make a table of values and plot the points.

θ	0°	45°	135°	270°	300°
r	4	4	4	4	4

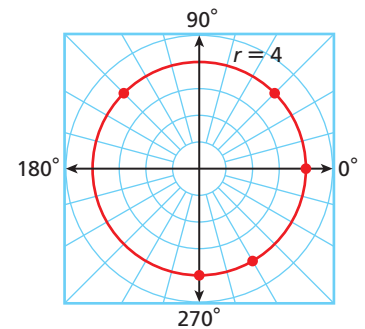
4. Graph $r = 2$.**EXTENSION****Exercises**

Convert to polar coordinates.

1. $(2, 2)$ 2. $(1, 0)$ 3. $(3, 7)$ 4. $(0, 15)$

Convert to rectangular coordinates.

5. $(3, 150^\circ)$ 6. $(5, 214^\circ)$ 7. $(4, 303^\circ)$ 8. $(4.5, 90^\circ)$

Plot each point.

9. $(4, 45^\circ)$ 10. $(3, 165^\circ)$ 11. $(1, 240^\circ)$ 12. $(3.5, 315^\circ)$

13. **Critical Thinking** Graph the equation $r = 5$. What can you say about the graph of an equation of the form $r = a$, where a is a positive real number?

**Technology** Graph each equation.

14. $r = -5 \sin \theta$ 15. $r = 3 \sin 4\theta$ 16. $r = -4 \cos \theta$
 17. $r = 5 \cos 3\theta$ 18. $r = 3 \cos 2\theta$ 19. $r = 2 + 4 \sin \theta$



For a complete list of the postulates and theorems in this chapter, see p. S82.

Vocabulary

adjacent arcs 757	exterior of a circle. 746	secant segment 793
arc 756	external secant segment. 793	sector of a circle 764
arc length 766	inscribed angle 772	segment of a circle 765
central angle 756	intercepted arc 772	semicircle 756
chord 746	interior of a circle. 746	subtend 772
common tangent 748	major arc 756	tangent of a circle. 746
concentric circles 747	minor arc 756	tangent circles. 747
congruent arcs 757	point of tangency 746	tangent segment. 794
congruent circles 747	secant 746	

Complete the sentences below with vocabulary words from the list above.

1. A(n) ? is a region bounded by an arc and a chord.
2. An angle whose vertex is at the center of a circle is called a(n) ?.
3. The measure of a(n) ? is 360° minus the measure of its central angle.
4. ? are coplanar circles with the same center.

11-1 Lines That Intersect Circles (pp. 746–754)



7.0, 16.0, 21.0

EXAMPLES

- Identify each line or segment that intersects $\odot A$.

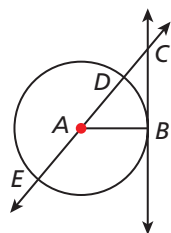

chord: \overline{DE}
 tangent: \overleftrightarrow{BC}
 radii: \overline{AE} , \overline{AD} , and \overline{AB}
 secant: \overleftrightarrow{DE}
 diameter: \overline{DE}

- \overline{RS} and \overline{RW} are tangent to $\odot T$. $RS = x + 5$ and $RW = 3x - 7$. Find RS .

$$\begin{aligned}
 RS &= RW && \text{2 segs. tangent to } \odot \text{ from} \\
 & && \text{same ext. pt. } \rightarrow \text{ segs. } \cong. \\
 x + 5 &= 3x - 7 && \text{Substitute the given values.} \\
 -2x + 5 &= -7 && \text{Subtract } 3x \text{ from both sides.} \\
 -2x &= -12 && \text{Subtract 5 from both sides.} \\
 x &= 6 && \text{Divide both sides by } -2. \\
 RS &= 6 + 5 && \text{Substitute 6 for } y. \\
 &= 11 && \text{Simplify.}
 \end{aligned}$$

EXERCISES

Identify each line or segment that intersects each circle.

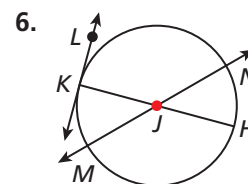
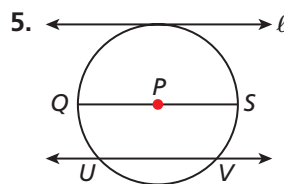

Given the measures of the following segments that are tangent to a circle, find each length.

7. $AB = 9x - 2$ and $BC = 7x + 4$. Find AB .
8. $EF = 5y + 32$ and $EG = 8 - y$. Find EG .
9. $JK = 8m - 5$ and $JL = 2m + 4$. Find JK .
10. $WX = 0.8x + 1.2$ and $WY = 2.4x$. Find WY .

11-2 Arcs and Chords (pp. 756–763)



EXAMPLES

Find each measure.

■ $m\widehat{BF}$

$\angle BAF$ and $\angle FAE$ are supplementary, so
 $m\angle BAF = 180^\circ - 62^\circ = 118^\circ$.
 $m\widehat{BF} = m\angle BAF = 118^\circ$

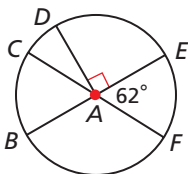

■ $m\widehat{DF}$

Since $m\angle DAE = 90^\circ$, $m\widehat{DE} = 90^\circ$.
 $m\angle EAF = 62^\circ$, so $m\widehat{EF} = 62^\circ$.
 By the Arc Addition Postulate,
 $m\widehat{DF} = m\widehat{DE} + m\widehat{EF} = 90^\circ + 62^\circ = 152^\circ$.

EXERCISES

Find each measure.

11. $m\widehat{KM}$

12. $m\widehat{HMK}$

13. $m\widehat{JK}$

14. $m\widehat{MJK}$

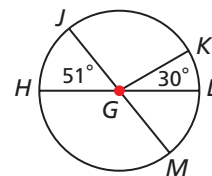

Find each length to the nearest tenth.

15. ST

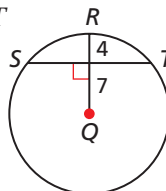

16. CD

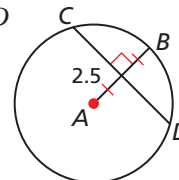

11-3 Sector Area and Arc Length (pp. 764–769)



EXAMPLES

- Find the area of sector PQR . Give your answer in terms of π and rounded to the nearest hundredth.

$$\begin{aligned} A &= \pi r^2 \left(\frac{m^\circ}{360^\circ} \right) \\ &= \pi (4)^2 \left(\frac{135^\circ}{360} \right) \\ &= 16\pi \left(\frac{3}{8} \right) \\ &= 6\pi \text{ m}^2 \\ &\approx 18.85 \text{ m}^2 \end{aligned}$$

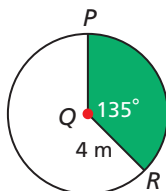

Find the area of each sector. Give your answer in terms of π and rounded to the nearest hundredth.

17. sector DEF

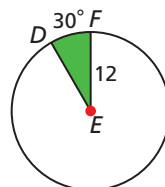

18. sector JKL

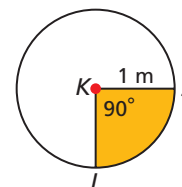

Find each arc length. Give your answer in terms of π and rounded to the nearest hundredth.

19. \widehat{GH}

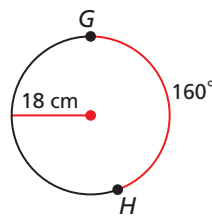

20. \widehat{MNP}

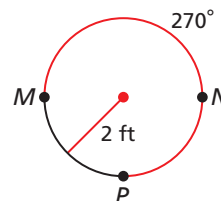

- Find the length of \widehat{AB} . Give your answer in terms of π and rounded to the nearest hundredth.

$$\begin{aligned} L &= 2\pi r \left(\frac{m^\circ}{360^\circ} \right) \\ &= 2\pi (9) \left(\frac{80^\circ}{360^\circ} \right) \\ &= 18\pi \left(\frac{4}{9} \right) \\ &= 8\pi \text{ ft} \\ &\approx 25.13 \text{ ft} \end{aligned}$$

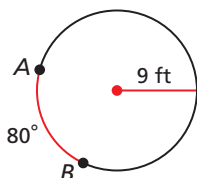

11-4 Inscribed Angles (pp. 772–779)



7.0, 16.0, 21.0

EXAMPLES

Find each measure.

■ $m\angle ABD$

By the Inscribed Angle Theorem,
 $m\angle ABD = \frac{1}{2}m\widehat{AD}$,
 so $m\angle ABD = \frac{1}{2}(108^\circ) = 54^\circ$.

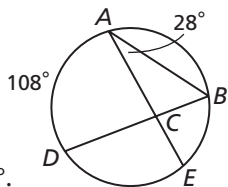

■ $m\widehat{BE}$

By the Inscribed Angle Theorem,
 $m\angle BAE = \frac{1}{2}m\widehat{BE}$. So $28^\circ = \frac{1}{2}m\widehat{BE}$,
 and $m\widehat{BE} = 2(28^\circ) = 56^\circ$.

EXERCISES

Find each measure.

21. $m\widehat{JL}$

22. $m\angle MKL$

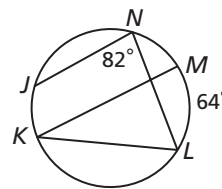

Find each value.

23. x

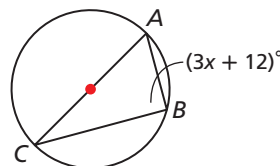

24. $m\angle RSP$

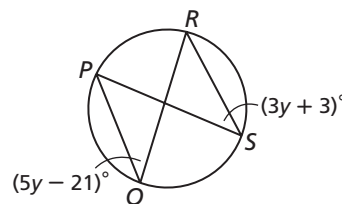

11-5 Angle Relationships in Circles (pp. 782–789)



7.0, 21.0

EXAMPLES

Find each measure.

■ $m\angle UWX$

$$\begin{aligned} m\angle UWX &= \frac{1}{2}m\widehat{UW} \\ &= \frac{1}{2}(160^\circ) \\ &= 80^\circ \end{aligned}$$

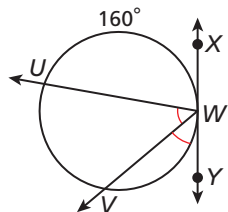

■ $m\widehat{VW}$

Since $m\angle UWX = 80^\circ$, $m\angle UWY = 100^\circ$
 and $m\angle VWY = 50^\circ$. $m\angle VWY = \frac{1}{2}m\widehat{VW}$.
 So $50^\circ = \frac{1}{2}m\widehat{VW}$, and $m\widehat{VW} = 2(50^\circ) = 100^\circ$.

■ $m\angle AED$

$$\begin{aligned} m\angle AED &= \frac{1}{2}(m\widehat{AD} + m\widehat{BC}) \\ &= \frac{1}{2}(31^\circ + 87^\circ) \\ &= \frac{1}{2}(118^\circ) \\ &= 59^\circ \end{aligned}$$

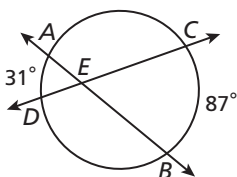

EXERCISES

Find each measure.

25. $m\widehat{MR}$

26. $m\angle QMR$

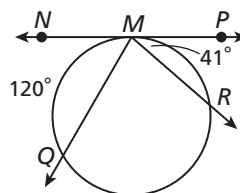

27. $m\angle GKH$

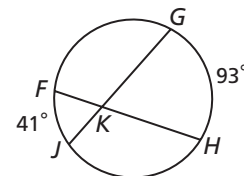

28. A piece of string art is made by placing 16 evenly spaced nails around the circumference of a circle. A piece of string is wound from A to B to C to D. What is $m\angle BXC$?

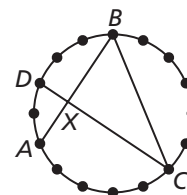

11-6 Segment Relationships in Circles (pp. 792–798)



EXAMPLES

- Find the value of x and the length of each chord.

$$AE \cdot EB = DE \cdot EC$$

$$12x = 8(6)$$

$$12x = 48$$

$$x = 4$$

$$AB = 12 + 4 = 16$$

$$DC = 8 + 6 = 14$$

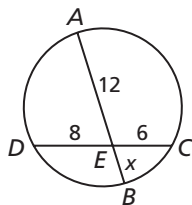

- Find the value of x and the length of each secant segment.

$$FJ \cdot FG = FK \cdot FH$$

$$16(4) = (6 + x)6$$

$$64 = 36 + 6x$$

$$28 = 6x$$

$$x = 4\frac{2}{3}$$

$$FJ = 12 + 4 = 16$$

$$FK = 4\frac{2}{3} + 6 = 10\frac{2}{3}$$

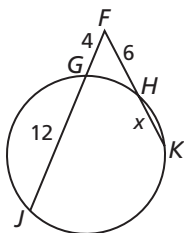

EXERCISES

Find the value of the variable and the length of each chord.

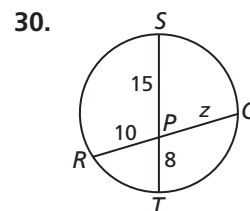
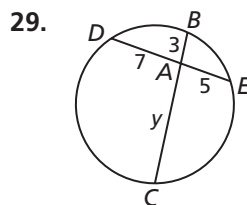

Find the value of the variable and the length of each secant segment.

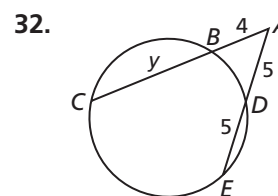
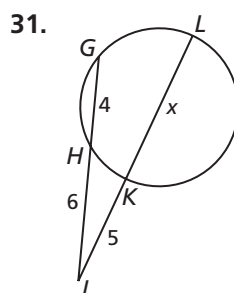

11-7 Circles in the Coordinate Plane (pp. 799–805)



EXAMPLES

- Write the equation of $\odot A$ that passes through $(-1, 1)$ and that has center $A(2, 3)$.

The equation of a circle with center (h, k) and radius r is $(x - h)^2 + (y - k)^2 = r^2$.

$$r = \sqrt{(2 - (-1))^2 + (3 - 1)^2} = \sqrt{3^2 + 2^2} = \sqrt{13}$$

The equation of $\odot A$ is $(x - 2)^2 + (y - 3)^2 = 13$.

- Graph $(x - 2)^2 + (y + 1)^2 = 4$.

The center of the circle is $(2, -1)$, and the radius is $\sqrt{4} = 2$.

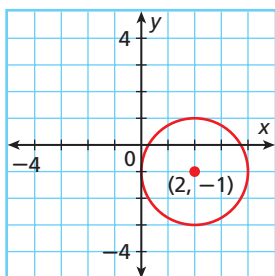

EXERCISES

Write the equation of each circle.

33. $\odot A$ with center $(-4, -3)$ and radius 3

34. $\odot B$ that passes through $(-2, -2)$ and that has center $B(-2, 0)$

35. $\odot C$

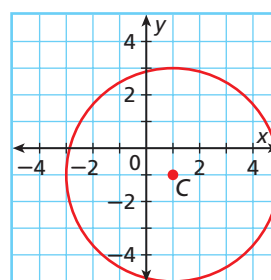

36. Graph $(x + 2)^2 + (y - 2)^2 = 1$.

- Identify each line or segment that intersects the circle.
- A jet is at a cruising altitude of 6.25 mi. To the nearest mile, what is the distance from the jet to a point on Earth's horizon? (*Hint:* The radius of Earth is 4000 mi.)

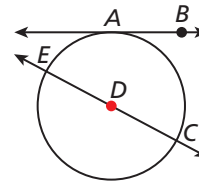

Find each measure.

3. $m\widehat{JK}$

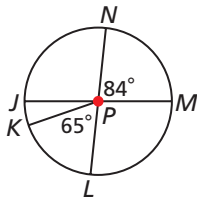

4. UV

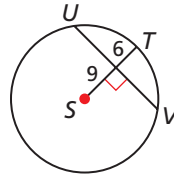

- Find the area of the sector. Give your answer in terms of π and rounded to the nearest hundredth.
- Find the length of \widehat{BC} . Give your answer in terms of π and rounded to the nearest hundredth.

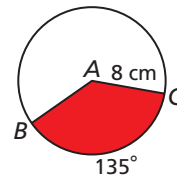

- If $m\angle SPR = 47^\circ$ in the diagram of a logo, find $m\widehat{SR}$.
- A printer is making a large version of the logo for a banner. According to the specifications, $m\widehat{PQ} = 58^\circ$. What should the measure of $\angle QTR$ be?



Find each measure.

9. $m\angle ABC$

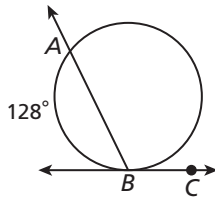

10. $m\angle NKL$

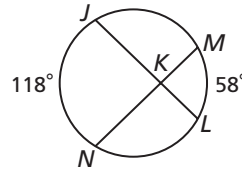

- A surveyor S is studying the positions of four columns A, B, C, and D that lie on a circle. He finds that $m\angle CSD = 42^\circ$ and $m\widehat{CD} = 124^\circ$. What is $m\widehat{AB}$?

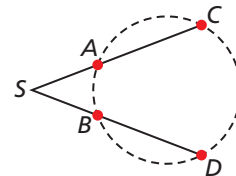

Find the value of the variable and the length of each chord or secant segment.

12.

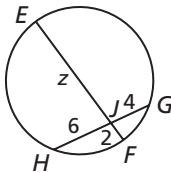

13.

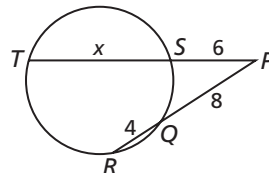

- The illustration shows a fragment of a circular plate. $AB = 8$ in., and $CD = 2$ in. What is the diameter of the plate?
- Write the equation of the circle that passes through $(-2, 4)$ and that has center $(1, -2)$.
- An artist uses a coordinate plane to plan a mural. The mural will include portraits of civic leaders at $X(2, 4)$, $Y(-6, 0)$, and $Z(2, -8)$ and a circle that passes through all three portraits. What are the coordinates of the center of the circle?

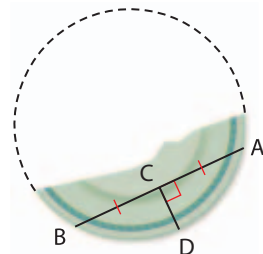

COLLEGE ENTRANCE EXAM PRACTICE



FOCUS ON SAT MATHEMATICS SUBJECT TESTS

The topics covered on the SAT Mathematics Subject Tests vary only slightly each time the test is administered. You can find out the general distribution of questions across topics, then determine which areas need more of your attention when you are studying for the test.



To prepare for the SAT Mathematics Subject Tests, start reviewing course material a couple of months before your test date. Take sample tests to find the areas you might need to focus on more. Remember that you are not expected to have studied all topics on the test.

You may want to time yourself as you take this practice test. It should take you about 6 minutes to complete.

1. \overline{AC} and \overline{BD} intersect at the center of the circle shown. If $m\angle BDC = 30^\circ$, what is the measure of minor \widehat{AB} ?

- (A) 15°
- (B) 30°
- (C) 60°
- (D) 105°
- (E) 120°

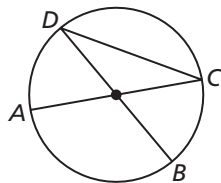

Note: Figure not drawn to scale.

2. Which of these is the equation of a circle that is tangent to the lines $x = 1$ and $y = 3$ and has radius 2?

- (A) $(x + 1)^2 + (y - 1)^2 = 4$
- (B) $(x - 1)^2 + (y + 1)^2 = 4$
- (C) $x^2 + (y - 1)^2 = 4$
- (D) $(x - 1)^2 + y^2 = 4$
- (E) $x^2 + y^2 = 4$

3. If $LK = 6$, $LN = 10$, and $PK = 3$, what is PM ?

- (A) 7
- (B) 8
- (C) 9
- (D) 10
- (E) 11

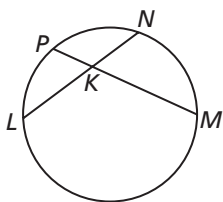

4. Circle D has radius 6, and $m\angle ABC = 25^\circ$. What is the length of minor \widehat{AC} ?

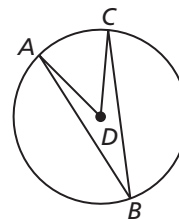

Note: Figure not drawn to scale.

- (A) $\frac{5\pi}{6}$
- (B) $\frac{5\pi}{4}$
- (C) $\frac{5\pi}{3}$
- (D) 3π
- (E) 5π

5. A square is inscribed in a circle as shown. If the radius of the circle is 9, what is the area of the shaded region, rounded to the nearest hundredth?

- (A) 11.56
- (B) 23.12
- (C) 57.84
- (D) 104.12
- (E) 156.23

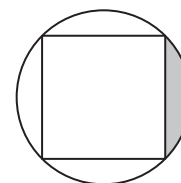

Multiple Choice: Choose Combinations of Answers

Given a multiple-choice test item where you are asked to choose from a combination of statements, the correct response is the most complete answer choice available. A strategy to use when solving these types of test items is to compare each given statement with the question and determine if it is true or false. If you determine that more than one of the statements is correct, then you can choose the combination that contains each correct statement.

EXAMPLE 1

Given that $\ell \parallel m$ and n is a transversal, which statement(s) are correct?

- I. $\angle 1 \cong \angle 3$ II. $\angle 2 \cong \angle 5$ III. $\angle 2 \cong \angle 8$

- (A) I only (C) II only
(B) I and II (D) I and III

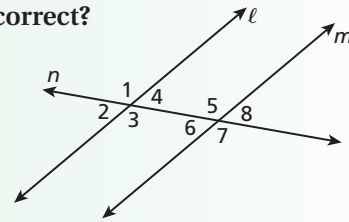

Look at each statement separately and determine if it is true or false. As you consider each statement, write true or false beside the statement.

Consider statement I: Because $\angle 1$ and $\angle 3$ are vertical angles and vertical angles are congruent, then this statement is TRUE. So the answer could be choice A, B, or D.

Consider statement II: $\angle 2 \cong \angle 4$ because they are vertical angles. $\angle 4$ and $\angle 5$ are supplementary angles because they are same-side interior angles. So $\angle 2$ and $\angle 5$ must be supplementary, not congruent. This statement is FALSE. The answer is NOT choice B or C.

Consider statement III: Because $\angle 2$ and $\angle 8$ are alternate exterior angles and alternate exterior angles are congruent, this statement is TRUE.

Since statements I and III are both true, choice D is correct.

You can also keep track of your statements in a table.

Statement	True/False
I	TRUE
II	FALSE
III	TRUE

Only I and III are
TRUE statements.



Make a table or write *T* or *F* beside each statement to keep track of whether it is true or false.

Read each test item and answer the questions that follow.

Item A

Which are chords of circle *W*?

- I. \overleftrightarrow{AB}
- II. \overline{WG}
- III. \overline{EC}
- IV. \overline{FD}

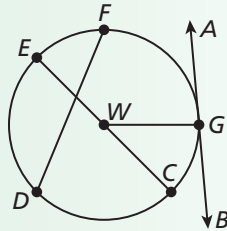

- (A) I only
- (B) III only
- (C) I and II
- (D) III and IV

- What is the definition of a chord?
- Determine if statements I, II, III, and IV are true or false. Explain your reasoning for each.
- Kristin realized that statement III was true and selected choice B as her response. Do you agree? Why or why not?

Item B

Classify $\triangle DEF$.

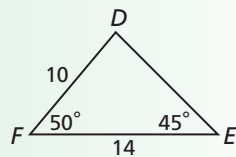

- (F) acute
- (G) acute scalene
- (H) obtuse
- (J) right equilateral

- How can you use the Triangle Sum Theorem to find all of the angle measures of $\triangle DEF$?
- Consider the angle measures of $\triangle DEF$. Is the triangle acute, right, or obtuse?
- Explain how you can use your answer to Problem 5 to eliminate two answer choices.
- Can a triangle be classified in any other way than by its angles? Explain.
- Which choice gives the most complete response?

Item C

Which describes the arc length of \widehat{AB} ?

- I. $\frac{17}{72}(24\pi)$
- II. $\frac{17\pi}{3}$
- III. $\frac{17}{36}(24\pi)$

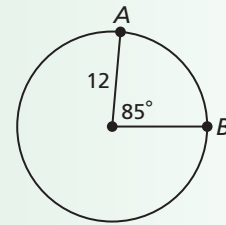

- (A) I only
- (B) II only
- (C) I and II
- (D) I, II, and III

- What is the formula to find arc length?
- Is statement I true or false? Explain.
- Decide if statement II is true or false. Should you select the answer choice yet? Why or why not?
- Can any answer choice be eliminated? Explain.
- Describe how you know which combination of statements is correct.

Item D

A rectangular prism has a length of 5 m, a height of 10 m, and a width of 4 m. Describe the change if the height and width of the prism are multiplied by $\frac{1}{2}$.

- I. The new volume is one fourth of the original volume.
- II. The new height is 20 m, and the new width is 2 m.
- III. The new surface area is less than half of the original surface area.

- (F) I only
- (G) II and III
- (H) I, II, and III
- (J) I and III

- Create a table and determine if each statement is true or false.
- Using your table, which choice is the most accurate?

CUMULATIVE ASSESSMENT, CHAPTERS 1-11

Multiple Choice

1. The composite figure is a right prism that shares a base with the regular pentagonal pyramid on top. If the lateral area of this figure is 328 square feet, what is the slant height of the pyramid?

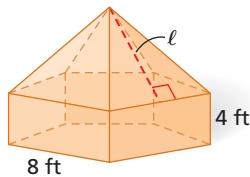

- (A) 2.5 feet (C) 8.4 feet
(B) 5.0 feet (D) 9.0 feet

2. What is the area of the polygon with vertices $A(2, 3)$, $B(12, 3)$, $C(6, 0)$, and $D(2, 0)$?

- (F) 12 square units (H) 30 square units
(G) 21 square units (J) 42 square units

Use the diagram for Items 3-5.

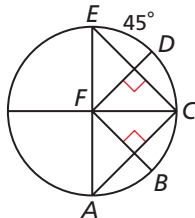

3. What is $m\widehat{BC}$?

- (A) 36° (C) 54°
(B) 45° (D) 72°

4. If the length of \widehat{ED} is 6π centimeters, what is the area of sector EFD ?

- (F) 20π square centimeters
(G) 72π square centimeters
(H) 120π square centimeters
(J) 240π square centimeters

5. Which of these line segments is NOT a chord of $\odot F$?

- (A) \overline{EC} (C) \overline{AF}
(B) \overline{CA} (D) \overline{AE}

6. $\triangle JKL$ is a right triangle where $m\angle K = 90^\circ$ and $\tan J = \frac{3}{4}$. Which of the following could be the side lengths of $\triangle JKL$?

- (F) $KL = 16$, $KJ = 12$, and $JL = 20$
(G) $KL = 15$, $KJ = 25$, and $JL = 20$
(H) $KL = 20$, $KJ = 16$, and $JL = 12$
(J) $KL = 18$, $KJ = 24$, and $JL = 30$

Use the diagram for Items 7 and 8.

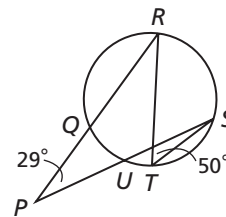

7. What is $m\widehat{QU}$?

- (A) 25° (C) 58°
(B) 42° (D) 71°

8. Which expression can be used to calculate the length of \overline{PS} ?

- (F) $\frac{PR \cdot PQ}{PU}$ (H) $\frac{PQ \cdot QR}{PU}$
(G) $\frac{PR \cdot PR}{PU}$ (J) $\frac{PQ \cdot PR}{PS}$

9. $\triangle ABC$ has vertices $A(0, 0)$, $B(-1, 3)$, and $C(2, 4)$. If $\triangle ABC \sim \triangle DEF$ and $\triangle DEF$ has vertices $D(5, -3)$, $E(4, -2)$, and $F(3, y)$, what is the value of y ?

- (A) -7 (C) -3
(B) -5 (D) -1

10. What is the equation of the circle with diameter \overline{MN} that has endpoints $M(-1, 1)$ and $N(3, -5)$?

- (F) $(x + 1)^2 + (y - 2)^2 = 13$
(G) $(x - 1)^2 + (y + 2)^2 = 13$
(H) $(x + 1)^2 + (y - 2)^2 = 26$
(J) $(x - 1)^2 + (y + 2)^2 = 52$



Remember that an important part of writing a proof is giving a justification for each step in the proof. Justifications may include theorems, postulates, definitions, properties, or the information that is given to you.

11. Kite $PQRS$ has diagonals \overline{PR} and \overline{QS} that intersect at T . Which of the following is the shortest segment from Q to \overline{PR} ?
- (A) \overline{PT} (C) \overline{RQ}
 (B) \overline{QP} (D) \overline{TQ}
12. If the perimeter of an equilateral triangle is reduced by a factor of $\frac{1}{2}$, what is the effect on the area of the triangle?
- (F) The area remains constant.
 (G) The area is reduced by a factor of $\frac{1}{2}$.
 (H) The area is reduced by a factor of $\frac{1}{4}$.
 (J) The area is reduced by a factor of $\frac{1}{6}$.
13. The area of a right isosceles triangle is 36 m^2 . What is the length of the hypotenuse of the triangle?
- (A) 6 meters (C) 12 meters
 (B) $6\sqrt{2}$ meters (D) $12\sqrt{2}$ meters

Gridded Response

14. The ratio of the side lengths of a triangle is 4:5:8. If the perimeter is 38.25 centimeters, what is the length in centimeters of the shortest side?
15. What is the geometric mean of 4 and 16?
16. For $\triangle HGJ$ and $\triangle LMK$ suppose that $\angle H \cong \angle L$, $HG = 4x + 5$, $KL = 9$, $HJ = 5x - 1$, and $LM = 13$. What must be the value of x to prove that $\triangle HGJ$ and $\triangle LMK$ are congruent by SAS?
17. If the length of a side of a regular hexagon is 2, what is the area of the hexagon to the nearest tenth?
18. What is the arc length of a semicircle in a circle with radius 5 millimeters? Round to the nearest hundredth.
19. What is the surface area of a sphere whose volume is 288π cubic centimeters? Round to the nearest hundredth.
20. Convert $(6, 60^\circ)$ to rectangular coordinates. What is the value of the x -coordinate?

Short Response

21. Use the diagram to find the value of x . Show your work or explain in words how you determined your answer.

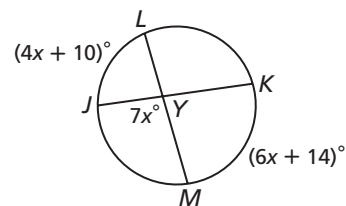

22. Paul needs to rent a storage unit. He finds one that has a length of 10 feet, a width of 5 feet, and a height of 9 feet. He finds a second storage unit that has a length of 11 feet, a width of 4 feet, and a height of 8 feet. Suppose that the first storage unit costs \$85.00 per month and that the second storage unit costs \$70.00 per month.
- a. Which storage unit has a lower price per cubic foot? Show your work or explain in words how you determined your answer.
- b. Paul finds a third storage unit that charges \$0.25 per cubic foot per month. What are possible dimensions of the storage unit if the charge is \$100.00 per month?
23. The equation of $\odot C$ is $x^2 + (y + 1)^2 = 25$.
- a. Graph $\odot C$.
- b. Write the equation of the line that is tangent to $\odot C$ at $(3, 3)$. Show your work or explain in words how you determined your answer.
24. A tangent and a secant intersect on a circle at the point of tangency and form an acute angle. Explain how you would find the range of possible measures for the intercepted arc.

Extended Response

25. Let $ABCD$ be a quadrilateral inscribed in a circle such that $\overline{AB} \parallel \overline{DC}$.

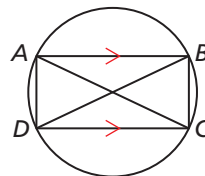

- a. Prove that $m\widehat{AD} = m\widehat{BC}$.
- b. Suppose $ABCD$ is a trapezoid. Show that $ABCD$ must be isosceles. Justify your answer.
- c. If $ABCD$ is not a trapezoid, explain why $ABCD$ must be a rectangle.